

## FSAV332 Wide Bandwidth Video Switch

### General Description

The Fairchild video switch FSAV32 is a quad high speed video switch. Low On Resistance allows inputs to be connected to outputs without adding propagation delay or generating additional ground bounce noise.

The device is organized as four 1-bit switches with separate output enable (OE) pins. When OE is LOW, the switch is ON and Port A is connected to Port B. When OE is HIGH, the switch is OPEN and a HIGH-Impedance state exists between the two ports.

### Features

- Wide bandwidth: 368 MHz
- -84 dB non adjacent channel crosstalk at 10MHz
- -49 dB Off Isolation at 10MHz
- 3Ω typical On Resistance ( $R_{ON}$ )
- Low power consumption (3uA maximum)
- Control input: TTL compatible

### Applications

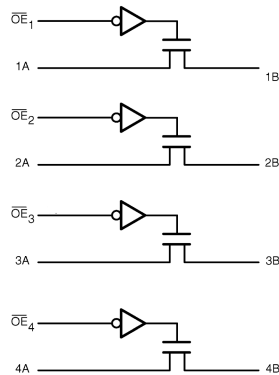
- Y/C video or CVBS video switch in LCD, plasma, and projector displays

### Ordering Code:

Order Number	Package Number	Package Description
FSAV332QSC	MQA16	16-Lead Quarter Size Outline Package (QSOP), JEDEC MO-137, 0.150" Wide
FSAV332MTC	MTC14	14-Lead Thin Shrink Small Outline Package (TSSOP), JEDEC MO-153, 4.4mm Wide
FSAV332MTC_NL	MTC14	Pb-Free 14-Lead Thin Shrink Small Outline Package (TSSOP), JEDEC MO-153, 4.4mm Wide

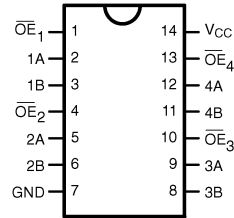
Devices also available in Tape and Reel. Specify by appending the suffix letter "X" to the ordering code.  
Pb-Free package per JEDEC J-STD-020B.

### Logic Diagram

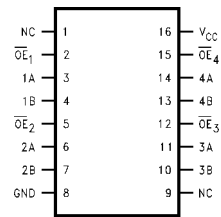


### Connection Diagrams

Pin Assignment for TSSOP



Pin Assignment for QSOP



### Pin Descriptions

Pin Name	Description
$\overline{OE}_1, \overline{OE}_2, \overline{OE}_3, \overline{OE}_4$	Bus Switch Enables
1A, 2A, 3A, 4A	Bus A
1B, 2B, 3B, 4B	Bus B
NC	Not Connected

### Truth Table

Inputs	Inputs/Outputs
$\overline{OE}$	A,B
L	A = B
H	Z

### Absolute Maximum Ratings (Note 1)

Supply Voltage ( $V_{CC}$ )	-0.5V to +7.0V
DC Switch Voltage ( $V_S$ ) (Note 2)	-0.5V to $V_{CC} + 0.5V$
DC Input Voltage ( $V_{IN}$ ) (Note 2)	-0.5V to +7.0V
DC Input Diode Current	-50 mA
DC Output Current	128 mA
Storage Temperature Range ( $T_{STG}$ )	-65°C to +150°C
ESD (Human Body Model)	4000V

### Recommended Operating Conditions (Note 3)

Supply Voltage ( $V_{CC}$ )	4.75V to 5.25V
Control Input Voltage	0V to $V_{CC}$
Switch Input Voltage	0V to $V_{CC}$
Operating Temperature	-40°C to +85°C
Thermal Resistance	
(TSSOP)	115°C/W
(TSSOP)	127°C/W

**Note 1:** The "Absolute Maximum Ratings" are those values beyond which the safety of the device cannot be guaranteed. The device should not be operated at these limits. The parametric values defined in the Electrical Characteristics tables are not guaranteed at the absolute maximum rating. The "Recommended Operating Conditions" table will define the conditions for actual device operation.

**Note 2:** The input and output negative voltage ratings may be exceeded if the input and output diode current ratings are observed.

**Note 3:** Unused control inputs must be held HIGH or LOW. They may not float.

### DC Electrical Characteristics All typical values are for $V_{CC} = 5V @ 25^\circ C$ unless otherwise specified.

Symbol	Parameter	$V_{CC}$ (V)	$T_A = -40^\circ C \text{ to } +85^\circ C$			Units	Conditions
			Min	Typ	Max		
$V_{ANALOG}$	Analog Signal Range	4.75 to 5.25	0		2.0	V	
$V_{IK}$	Clamp Diode Voltage	4.75			-1.2	V	$I_{IN} = -18 \text{ mA}$
$V_{IH}$	Input Voltage HIGH	4.75 to 5.25	2.0			V	
$V_{IL}$	Input Voltage LOW	4.75 to 5.25			0.8	V	
$I_{IN}$	Control Input Leakage	5.25			$\pm 1.0$	$\mu A$	$V_{IN} = 0V \text{ to } V_{CC}$
$I_{OZ}$	OFF State Leakage Current	5.25			$\pm 1.0$	$\mu A$	$0 \leq A, B \leq V_{CC}$
$R_{ON}$	Switch On Resistance (Note 4)	4.75		3.0	7.0	$\Omega$	$V_{IN} = 1V, R_L = 75\Omega, I_{ON} = 13 \text{ mA}$
		4.75		7.0	10.0		$V_{IN} = 2V, R_L = 75\Omega, I_{ON} = 26 \text{ mA}$
$I_{CC}$	Quiescent Supply Current	5.25			3.0	$\mu A$	$V_{IN} = 0V \text{ } V_{CC} \text{ or } I_{OUT} = 0$

**Note 4:** Measured by the voltage drop between A and B pins at the indicated current through the switch. On Resistance is determined by the lower of the voltages on the two (A or B Ports).

## AC Electrical Characteristics

All typical value are for  $V_{CC} = 5V$  @  $25^{\circ}C$  unless otherwise specified.

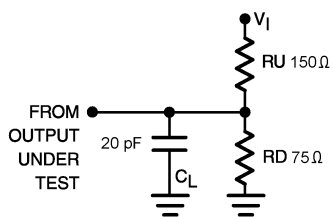
Symbol	Parameter	$V_{CC}$ (V)	$T_A = -40^{\circ}C$ to $+85^{\circ}C$			Units	Conditions	Figure Number
			Min		Max			
$t_{ON}$	Turn ON Time	4.75 to 5.25	1.0		5.0	ns	$V_I = 7V$ for $t_{pZL}$ and $V_I = OPEN$ for $t_{pZH}$	Figures 1, 2
$t_{OFF}$	Turn OFF Time	4.75 to 5.25	1.0		5.0	ns	$V_I = 7V$ for $t_{pLZ}$ and $V_I = OPEN$ for $t_{pHZ}$	Figures 1, 2
$t_{PLH}$ $t_{PHL}$	Propagation Delay (Note 5)	4.75 to 5.25			0.1	ns	$V_I = OPEN$	Figures 1, 2
DG	Differential Gain	4.75 to 5.25		0.29		%	$R_L = 150\Omega$ , $f = 3.58MHz$	
DP	Differential Phase	4.75 to 5.25		0.10		Degree	$R_L = 150\Omega$ , $f = 3.58MHz$	
$O_{IRR}$	OFF-Isolation	4.75 to 5.25				dB	$f = 10MHz$ , $R_L = 150\Omega$	Figure 3
$X_{TALK}$	Non Adjacent Channel Crosstalk	4.75 to 5.25		-54.0		dB	$R_L = 150\Omega$ , $f = 10MHz$	Figure 4
BW	-3dB Bandwidth	4.75 to 5.25		368		MHz	$R_L = 150\Omega$	Figure 5

Note 5: This specification is guaranteed by design.

## Capacitance

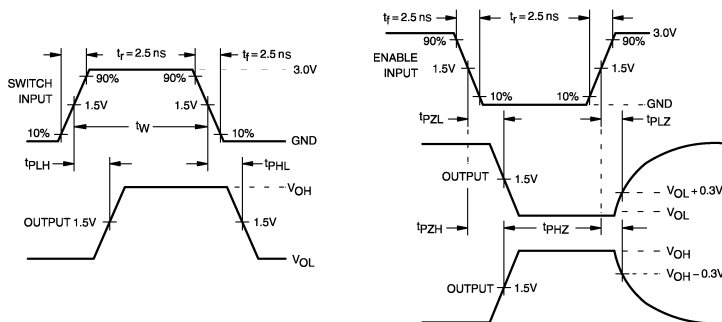
Symbol	Parameter	$T_A = -40^{\circ}C$ to $+85^{\circ}C$		Conditions
		Typ	Units	
$C_{IN}$	Control Pin Input Capacitance	3.0	pF	$V_{CC} = 5.0V$
$C_{ON}$	A/B ON Capacitance	30.0	pF	$V_{CC} = 5.0V$ , $OE = 0V$
$C_{OFF}$	Port B OFF Capacitance	5.0	pF	$V_{CC}$ and $OE = 5.0V$

## AC Loading and Waveforms



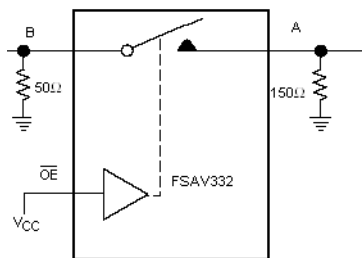
**Note:** Input driven by 50 Ω source terminated in 50 Ω  
**Note:**  $C_L$  includes load and stray capacitance  
**Note:** Input PRR = 1.0 MHz,  $t_W = 500$ ns

**FIGURE 1. AC Test Circuit**

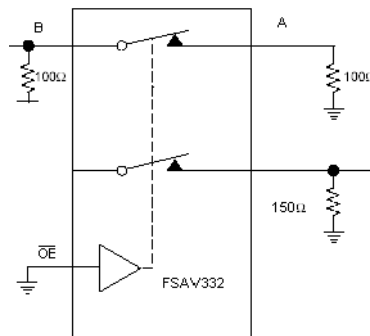


**FIGURE 2. AC Waveforms**

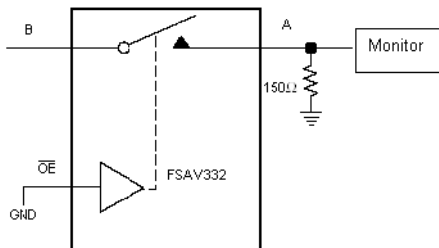
## Test Diagrams



**FIGURE 3. OFF Isolation Test**

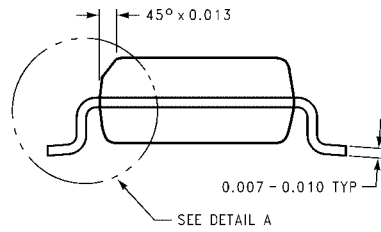
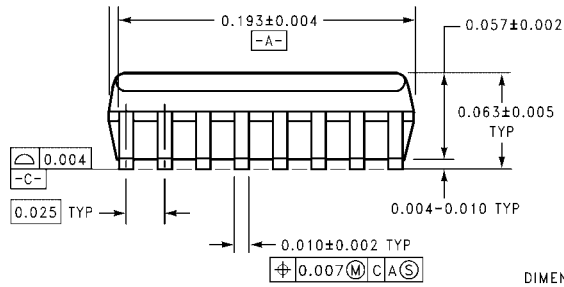
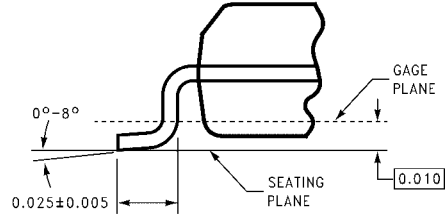
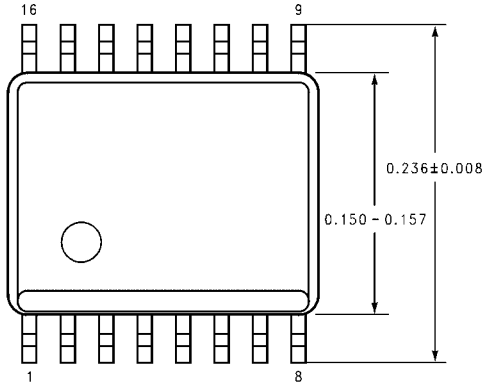


**FIGURE 4. Crosstalk Test**



**FIGURE 5. Bandwidth Test**

**Physical Dimensions** inches (millimeters) unless otherwise noted

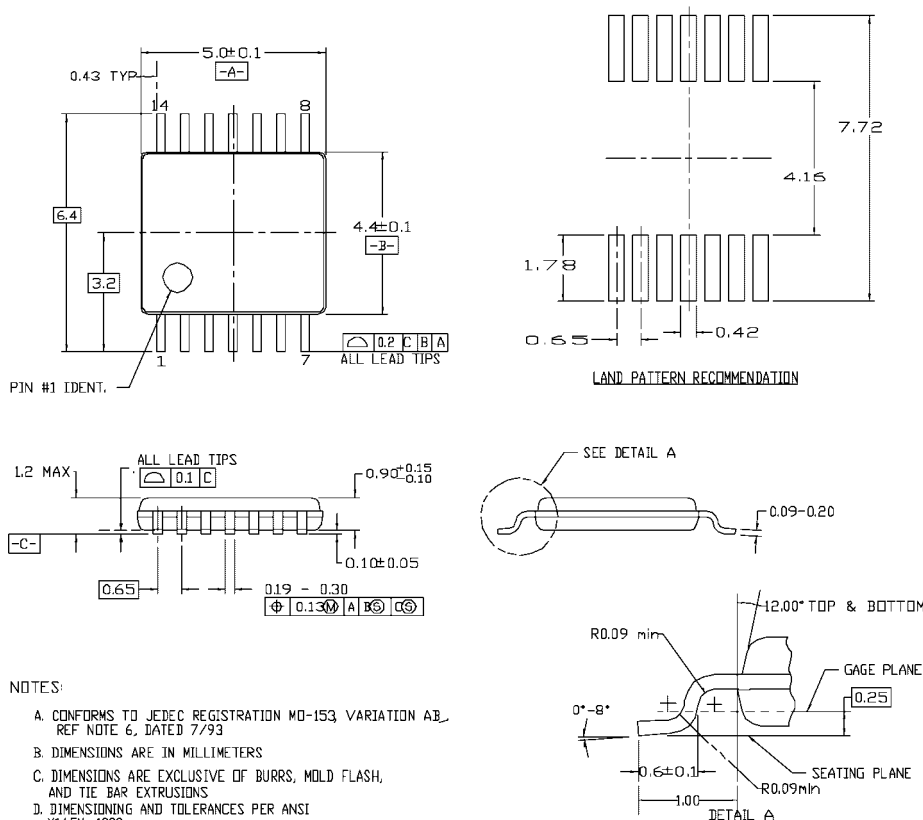


DIMENSIONS ARE IN INCHES

MQA16 (REV A)

**16-Lead Quarter Size Outline Package (QSOP), JEDEC MO-137, 0.150" Wide  
Package Number MQA16**

**Physical Dimensions** inches (millimeters) unless otherwise noted (Continued)



- NOTES:
- A. CONFORMS TO JEDEC REGISTRATION MO-153, VARIATION AB, REF NOTE 6, DATED 7/93
  - B. DIMENSIONS ARE IN MILLIMETERS
  - C. DIMENSIONS ARE EXCLUSIVE OF BURRS, MOLD FLASH, AND TIE BAR EXTRUSIONS
  - D. DIMENSIONING AND TOLERANCES PER ANSI Y14.5M, 1982

MTC14revD

**14-Lead Thin Shrink Small Outline Package (TSSOP), JEDEC MO-153, 4.4mm Wide Package Number MTC14**

**Technology Description**

The Fairchild Switch family derives from and embodies Fairchild's proven switch technology used for several years in its 74LVX3L384 (FST3384) bus switch product.

Fairchild does not assume any responsibility for use of any circuitry described, no circuit patent licenses are implied and Fairchild reserves the right at any time without notice to change said circuitry and specifications.

**LIFE SUPPORT POLICY**

FAIRCHILD'S PRODUCTS ARE NOT AUTHORIZED FOR USE AS CRITICAL COMPONENTS IN LIFE SUPPORT DEVICES OR SYSTEMS WITHOUT THE EXPRESS WRITTEN APPROVAL OF THE PRESIDENT OF FAIRCHILD SEMICONDUCTOR CORPORATION. As used herein:

1. Life support devices or systems are devices or systems which, (a) are intended for surgical implant into the body, or (b) support or sustain life, and (c) whose failure to perform when properly used in accordance with instructions for use provided in the labeling, can be reasonably expected to result in a significant injury to the user.
2. A critical component in any component of a life support device or system whose failure to perform can be reasonably expected to cause the failure of the life support device or system, or to affect its safety or effectiveness.

[www.fairchildsemi.com](http://www.fairchildsemi.com)