

## GENERAL DESCRIPTION

The CM2596 series are step-down switching regulators with all required active functions. It is capable of driving 3A load with excellent line and load regulations. These devices are available in fixed output voltages of 3.3V, 5V, and an adjustable output version.

The CM2596 series offers a high-efficiency replacement for popular three-terminal linear regulators. Also it requires a minimum number of external components. It substantially not only reduces the area of board size but also the size of the heat sink, and in some cases no heat sink is required.

±4% tolerance on output voltage within specified input voltages and output load conditions is guaranteed. Also, the oscillator frequency accuracy is within ±10%. External shutdown is included, featuring 70µA (typical) standby current. The output switch includes cycle-by-cycle current limiting, as well as thermal shutdown for full protection under fault conditions.

## APPLICATIONS

- ◆ LCD Monitors
- ◆ ADD-ON Cards Switching Regulators
- ◆ High Efficiency Step-Down Regulators
- ◆ Efficient Pre-regulator for Linear Regulators

## FEATURES

- ◆ Guaranteed 3A output current
- ◆ 3.3V, 5V, and adjustable versions
- ◆ Wide input voltage range, up to 40V
- ◆ Internal oscillator of 150KHz fixed frequency
- ◆ Wide adjustable version output voltage range, from 1.23V to 37V±4% max over line and load conditions
- ◆ Low standby current, typ. 80µA, at shutdown mode
- ◆ Requires only 4 external components
- ◆ Thermal shutdown and current limit protection
- ◆ Requires only 4 external components
- ◆ Excellent line and load regulation specifications
- ◆ TTL shutdown capability

## ORDERING INFORMATION

Package Type		Output Voltage
TO-220	TO-263	
CM2596SJC�220	CM2596SJC�263	3.3V
CM2596ZJC�220	CM2596ZJC�263	5.0V
CM2596CN220	CM2596CN263	ADJ.
CM2596GSJC�220	CM2596GSJC�263	3.3V
CM2596GZJC�220	CM2596GZJC�263	5.0V
CM2596GC�220	CM2596GC�263	ADJ.

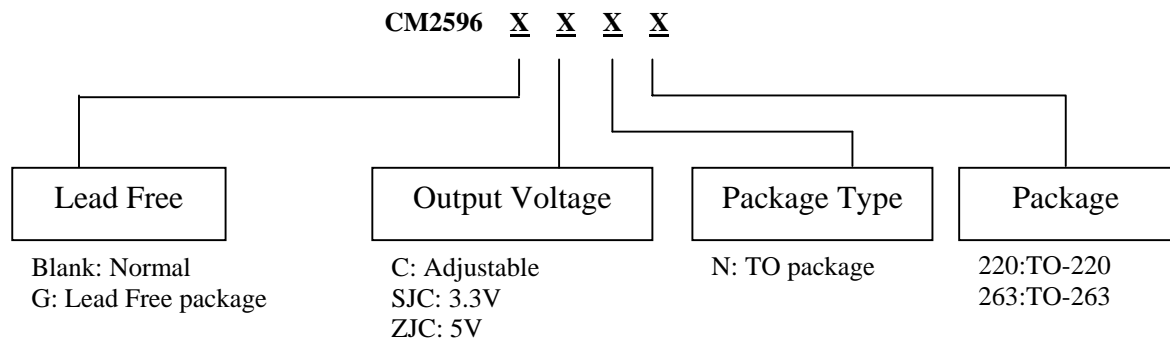

### PIN CONFIGURATION

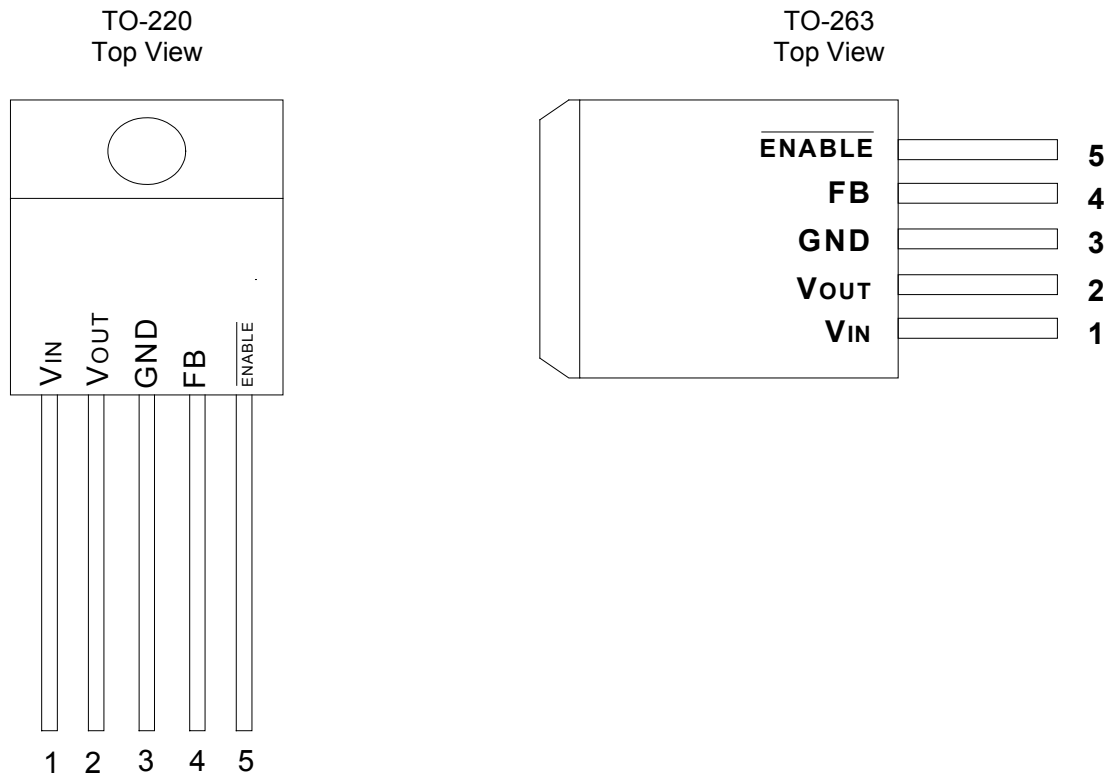

### ABSOLUTE MAXIMUM RATINGS

Input Voltage ( $V_{POWER}$ )	.....	+45V
ENABLE Pin Input Voltage	.....	$-0.3V \leq V \leq V_{IN}$
Storage Temperature	.....	$-65^{\circ}C$ to $+150^{\circ}C$
Lead Temperature (10 sec.)	.....	$260^{\circ}C$
Operating Temperature	.....	$-40^{\circ}C$ to $+125^{\circ}C$

### POWER DISSIPATION TABLE

Package	$\Theta_{JA}$ ( $^{\circ}C/W$ )	Derating factor (mW/ $^{\circ}C$ ) $T_A \geq 25^{\circ}C$	$T_A \leq 25^{\circ}C$ Power rating (mW)	$T_A = 70^{\circ}C$ Power rating (mW)	$T_A = 85^{\circ}C$ Power rating (mW)
TO-220	45	22.2	2775	1776	1443
TO-263	45	22.2	2775	1776	1443

Note:

- $\Theta_{JA}$  : Thermal Resistance-Junction to Ambient,  $D_F$ : Derating factor,  $P_O$ : Power consumption.  
Junction Temperature Calculation:  $T_J = T_A + (P_D \times \Theta_{JA})$ ,  $P_O = D_F \times (T_J - T_A)$   
The  $\Theta_{JA}$  numbers are guidelines for the thermal performance of the device/PC-board system.  
All of the above assume no ambient airflow.
- $\Theta_{JT}$  : Thermal Resistance-Junction to Ambient,  $T_C$ : case (Tab) temperature,  $T_J = T_C + (P_D \times \Theta_{JA})$

### ELECTRICAL CHARACTERISTICS

Electrical Characteristics at  $I_{OUT} = 0mA$ , and  $T_J = +25^{\circ}C$ ; unless otherwise noted

Parameter	Device	Test Conditions		CM2596			Unit
				Min.	Typ.	Max.	
Output Voltage (Note 1)	CM2596S	Test circuit of Figure 1		3.234	3.300	3.366	V
	CM2596ZJ			4.900	5.000	5.100	V
Output Voltage (Note 1)	CM2596S	$6V \leq V_{IN} \leq 40V$	$0.2A \leq I_{LOAD} \leq 3A$	3.168	3.300	3.432	V
	CM2596ZJ	$8V \leq V_{IN} \leq 40V$		4.800	5.000	5.200	V
Output Voltage (Note 1)	CM2596S	$6V \leq V_{IN} \leq 40V$	$0.2A \leq I_{LOAD} \leq 3A$ , $-40^{\circ}C \leq T_J \leq 125^{\circ}C$ Test circuit of Figure 1	3.135	3.300	3.482	V
	CM2596ZJ	$8V \leq V_{IN} \leq 40V$		4.750	5.000	5.250	V
Feedback Voltage (Note 1)	CM2596 (Adj)	Test circuit of Figure 2	$V_{OUT} = 5V$	1.217	1.230	1.243	V
Feedback Voltage (Note 1)	CM2596 (Adj)	$8V \leq V_{IN} \leq 40V$ , $V_{OUT} = 5V$ Test circuit of Figure 2	$0.5A \leq I_{LOAD} \leq 3A$	1.193	1.230	1.267	V
Feedback Voltage (Note 1)	CM2596 (Adj)	$8V \leq V_{IN} \leq 40V$ , $V_{OUT} = 5V$ Test circuit of Figure 2	$0.5A \leq I_{LOAD} \leq 3A$ , $-40^{\circ}C \leq T_J \leq 125^{\circ}C$	1.180	1.230	1.286	V
Efficiency	CM2596S	$I_{LOAD} = 3A$			75		%
	CM2596ZJ				77		
	CM2596(adj)	$I_{LOAD} = 3A$ , $V_{OUT} = 5V$			77		%
Oscillator Frequency	Note 2	$T_J = 25^{\circ}C$		127	150	173	kHz
		$-40^{\circ}C \leq T_J \leq 125^{\circ}C$		110	150	173	
Quiescent Current	Note 3				5	10	mA
Standby Current	$\overline{ENABLE} = 5V$				80	200	$\mu A$
Saturation Voltage	$I_{LOAD} = 3A$ (Note 4)	$T_J = 25^{\circ}C$			1.4	1.8	V
		$-40^{\circ}C \leq T_J \leq 125^{\circ}C$				2.0	
Feedback Bias Current	$V_{OUT} = 5V$ (Adj. Version only)	$T_J = 25^{\circ}C$			50	100	nA
		$-40^{\circ}C \leq T_J \leq 125^{\circ}C$				500	
Duty Cycle (ON)	Note 5			93	98		%
Current Limit	Note 2,4	$T_J = 25^{\circ}C$		4.2	7	8.8	A
		$-40^{\circ}C \leq T_J \leq 125^{\circ}C$		3.5	7.2	9.0	
Output Leakage Current	Note 3	$V_{OUT} = 0V$			0.3	2	mA
		$V_{OUT} = -1V$			9	20	
$\overline{ENABLE}$ Threshold Voltage	$V_{IH}$ ( $V_{OUT} = 0V$ )	$T_J = 25^{\circ}C$		2.2	1.4		V
		$-40^{\circ}C \leq T_J \leq 125^{\circ}C$		2.4			
	$V_{IL}$ ( $V_{OUT} =$ Normal Output Voltage)	$T_J = 25^{\circ}C$			1.2	1.0	V
		$-40^{\circ}C \leq T_J \leq 125^{\circ}C$				0.8	
$\overline{ENABLE}$ Input Current	$I_{IH}$ ( $\overline{ENABLE} = 5V$ )				12	30	$\mu A$
	$I_{IH}$ ( $\overline{ENABLE} = 0V$ )				0	10	

**Note 1:** External components such as the catch diode, inductor, input and output capacitors can affect switching regulator system performance. Refer to Application Information for details.

**Note 2:** The oscillator frequency reduces to approximately 11KHz in the event of fault conditions, such as output short or overload. And the regulated output voltage will drop approximately 40% from the nominal output voltage. This self-protection feature lowers the average power dissipation by lowering the minimum duty cycle from 5% down to approximately 2%.

**Note 3:** For these parameters, FB is removed from  $V_{OUT}$  and connected to +12V to force the output transistor OFF.

**Note 4:**  $V_{OUT}$  pin sourcing current. No diode, inductor or capacitor connect to  $V_{OUT}$ .

**Note 5:** FB is removed from  $V_{OUT}$  and connected to 0V.

### BLOCK DIAGRAM

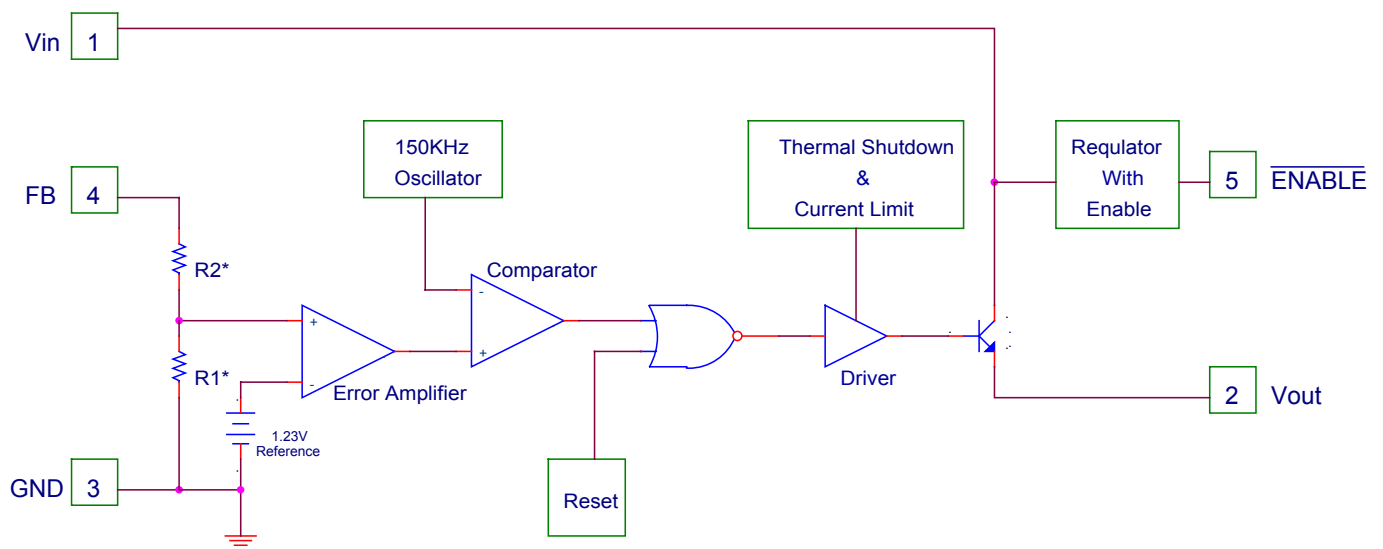

### APPLICATION CIRCUIT

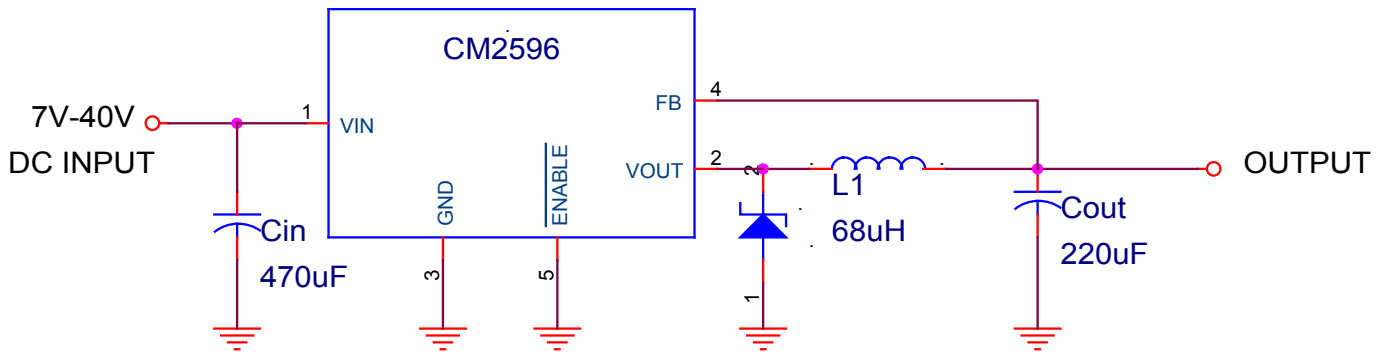

Figure1. Fixed Output Voltage Versions

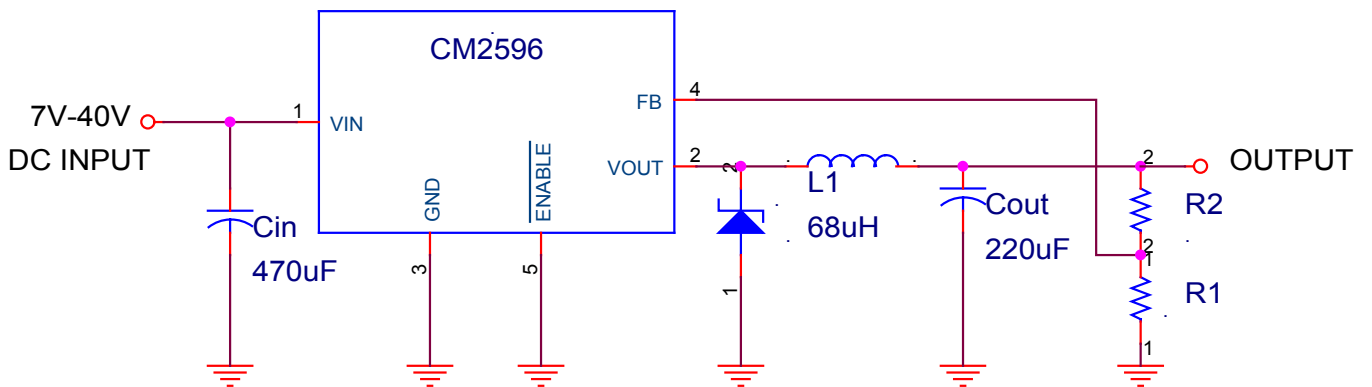

Figure2. Adjustable Output Voltage Versions

$$V_{out} = V_{ref} ( 1 + R2 / R1 )$$

$$R2 = R1 ( V_{out} / V_{ref} - 1 )$$

Where  $V_{ref} = 1.23V$  ,  $R1$  between  $1K$  and  $5k$

### TYPICAL CHARACTERISTICS

Line regulation

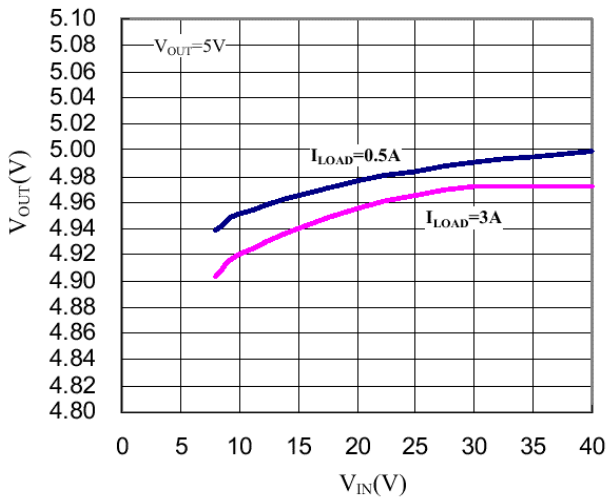

Output voltage vs. temperature

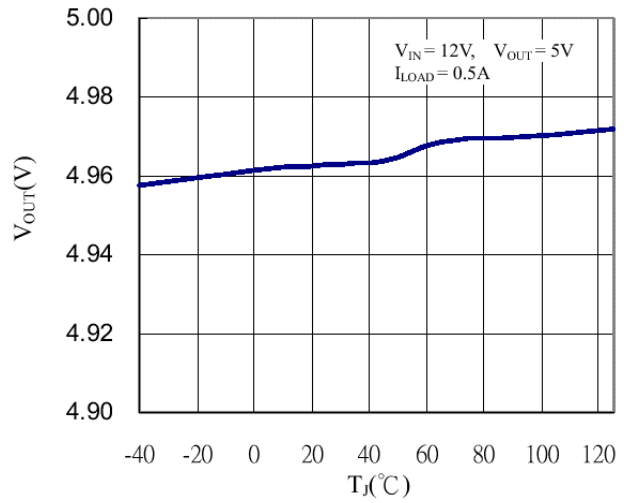

Current limit vs. temperature

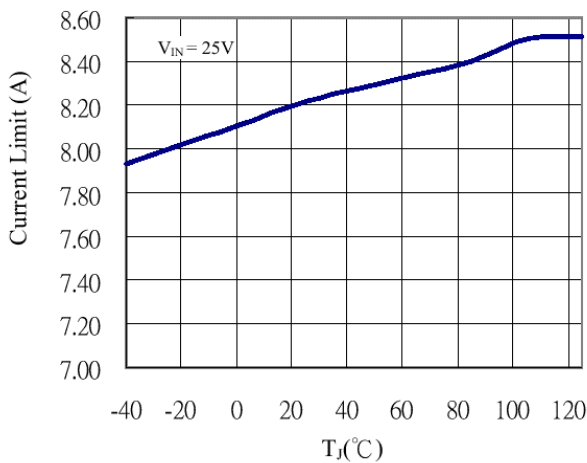

Quiescent current vs. input voltage

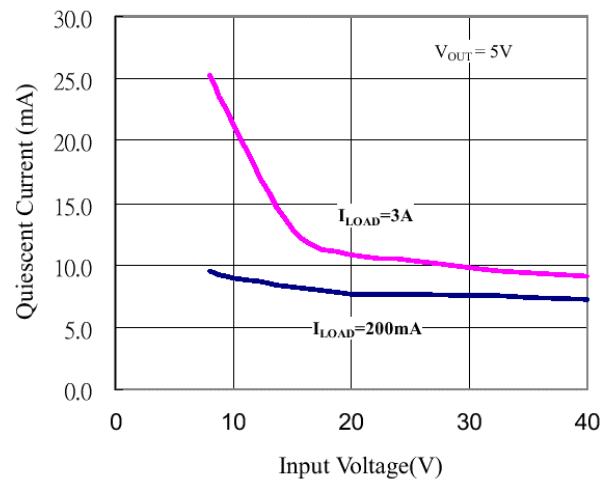

Dropout voltage vs. temperature

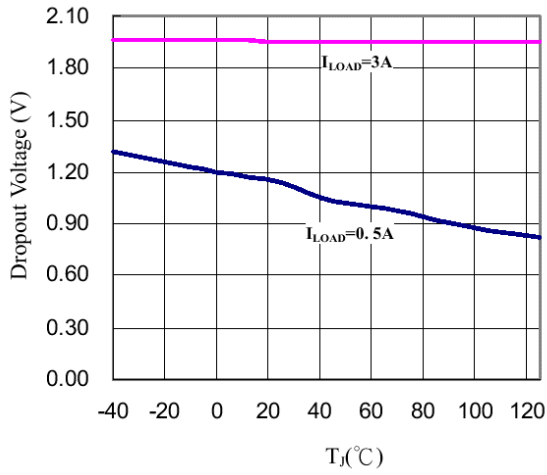

Standby current vs. temperature

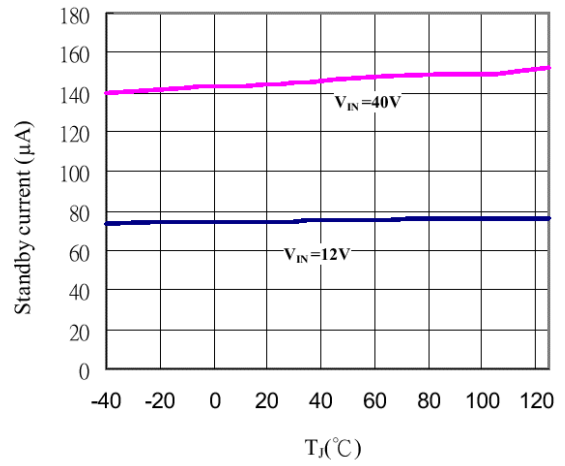

Saturation voltage vs. load current

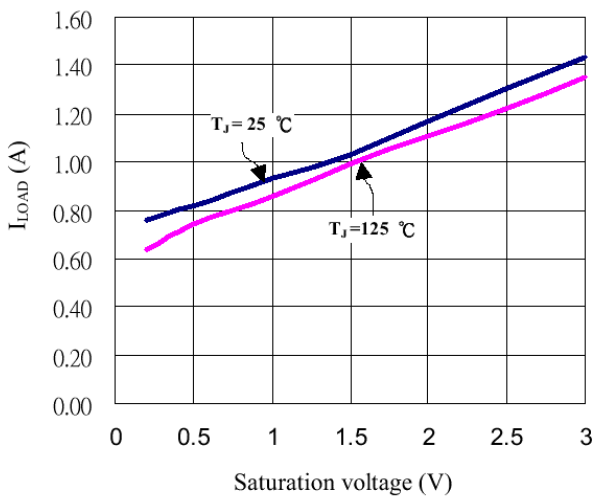

Load transient response

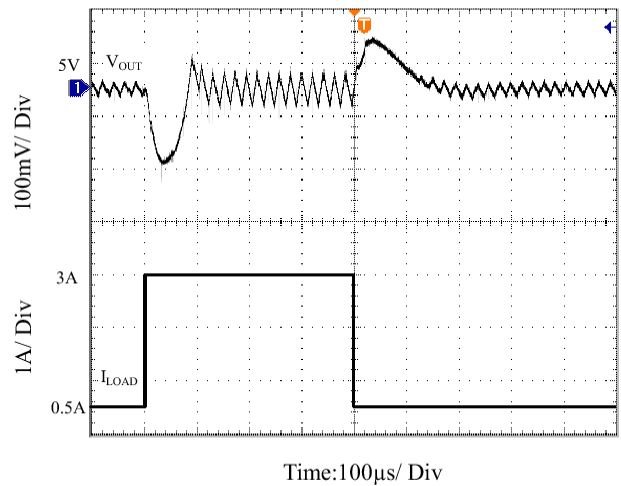

## APPLICATION INFORMATION

### External component selector

#### Input Capacitors (C<sub>in</sub>)

It is required that V<sub>IN</sub> must be bypassed with at least a 100uF electrolytic capacitor for stability. Also, it is strongly recommended the capacitor's leads must be short, wide and located near the regulator as possible. The important parameters for the capacitor are the voltage rating and the RMS current rating. For a maximum ambient temperature of 40°C, a general guideline would be to select a capacitor with a ripple current rating of approximately 50% of the DC load current. The capacitor voltage rating must be at least 1.25 times greater than the maximum input voltage.

For low operating temperature range, for example, below -25°C, the input capacitor value may need to be larger. This is due to the reason that the capacitance value of electrolytic capacitors decreases and the ESR increases with lower temperatures and age. Paralleling a ceramic or solid tantalum capacitor will increase the regulator stability at cold temperatures.

#### Output Capacitors (C<sub>out</sub>)

An output capacitor is also required to filter the output voltage and is needed for loop stability. The capacitor should be located near the CM2596 using short PC board traces. Low ESR types capacitors are recommended for low output ripple voltage and good stability. Generally, low value or low voltage (less than 12V) electrolytic capacitors usually have higher ESR numbers. For example, the lower capacitor values (220uF – 1000uF) will yield typically 50mV to 150mV of output ripple voltage, while larger-value capacitors will reduce the ripple to approximately 20mV to 50mV.

The amount of output ripple voltage is primarily a function of the ESR (Equivalent Series Resistance) of the output capacitor and the amplitude of the inductor ripple current ( $\Delta I_{IND}$ ).

$$\text{Output Ripple Voltage} = (\Delta I_{IND}) \times (\text{ESR of } C_{OUT})$$

Some capacitors called "high-frequency", "low-inductance", or "low-ESR" are recommended to use to further reduce the output ripple voltage to 10mV or 20mV. However, very low ESR capacitors, such as Tantalum capacitors, should be carefully evaluated.

#### Catch Diode

This diode is required to provide a return path for the inductor current when the switch is off. It should be located close to the CM2596 using short leads and short printed circuit traces as possible.

To satisfy the need of fast switching speed and low forward voltage drop, Schottky diodes are widely used to provide the best efficiency, especially in low output voltage switching regulators (less than 5V). Besides, fast-Recovery, high-efficiency, or ultra-fast recovery diodes are also suitable. But some types with an abrupt turn-off characteristic may cause instability and EMI problems. A fast-recovery diode with soft recovery characteristics is better choice.



### Output Voltage Ripple and Transients

The output ripple voltage is due mainly to the inductor sawtooth ripple current multiplied by the ESR of the output capacitor. The output ripple voltage of a switching power supply will contain a sawtooth ripple voltages at the switcher frequency, typically about 1% of the output voltages, and may also contain short voltage spikes of the sawtooth waveform.

Due to the fast switching action, and the parasitic inductance of the output filter capacitor, there is voltage spikes presenting at the peaks of the sawtooth waveform. Cautions must be taken for stray capacitance, wiring inductance, and even the scope probes used for transients evaluation. To minimize these voltage spikes, shortening the lead length and PCB traces is always the first thought. Further more, an additional small LC filter (30uH & 100uF) (as shown in Figure 3) will possibly provide a 10X reduction in output ripple voltage and transients.

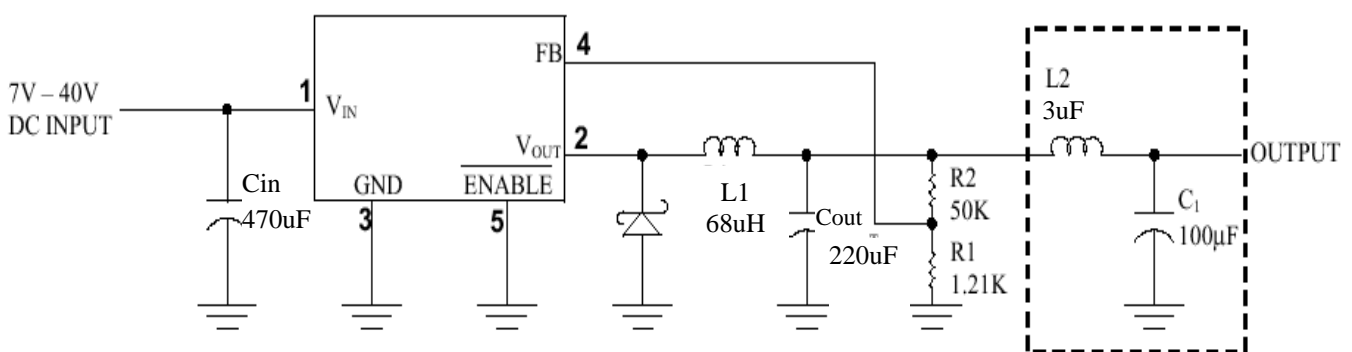

**Figure 3. LC Filter for Low Output Ripple**

### Inductor Selection

The CM2596 can be used for either continuous or discontinuous modes of operation. Each mode has distinctively different operating characteristics, which can affect the regulator performance and requirements.

With relatively heavy load currents, the circuit operates in the continuous mode (inductor current always flowing), but under light load conditions, the circuit will be forced to the discontinuous mode (inductor current falls to zero for a period of time). For light loads (less than approximately 300mA) it may be desirable to operate the regulator in the discontinuous mode, primarily because of the lower inductor values required for the discontinuous mode.

Inductors are available in different styles such as pot core, toroid, E-frame, bobbin core, et., as well as different core materials, such as ferrites and powdered iron. The least expensive, the bobbin core type, consists of wire wrapped on a ferrite rod core. This type of construction makes for an inexpensive inductor, but since the magnetic flux is not completely contained within the core, it generates more electromagnetic interference (EMI). This EMI can cause problems in sensitive circuits, or can give incorrect scope readings because of induced voltages in the scope probe.

An inductor should not be operated beyond its maximum rated current because it may saturate. When an inductor begins to saturate, the inductance decreases rapidly and the inductor begins to look mainly resistive (the DC resistance of the winding). This will cause the switch current to rise very rapidly. Different inductor types have different saturation characteristics, and this should be well considered when selecting as inductor.

### Feedback Connection

For fixed output voltage version, the FB (feedback) pin must be connected to  $V_{OUT}$ . For the adjustable version, it is important to place the output voltage ratio resistors near CM2596 as possible in order to minimize the noise introduction.

### Enable

It is required that the ENABLE must not be left open. For normal operation, connect this pin to a “LOW” voltage (typically, below 1.6V). On the other hand, for standby mode, connect this pin with a “HIGH” voltage. This pin can be safely pulled up to  $+V_{IN}$  without a resistor in series with it.

### Grounding

To maintain output voltage stability, the power ground connections must be low-impedance. For the 5-lead TO-220 and TO-263 style package, both the tab and pin 3 are ground and either connection may be used.

### Heatsink and Thermal Consideration

Although the CM2596 requires only a small heatsink for most cases, the following thermal consideration is important for all operation. With the package thermal resistances  $\theta_{JA}$  and  $\theta_{JC}$ , total power dissipation can be estimated as follows:

$$P_D = (V_{IN} \times I_Q) + (V_{OUT} / V_{IN})(I_{LOAD} \times V_{SAT});$$

When no heatsink is used, the junction temperature rise can be determined by the following:

$$\Delta T_J = P_D \times \theta_{JA};$$

With the ambient temperature, the actual junction temperature will be:

$$T_J = \Delta T_J + T_A;$$

If the actual operating junction temperature is out of the safe operating junction temperature (typically 125°C), then a heatsink is required. When using a heatsink, the junction temperature rise will be reduced by the following:

$$\Delta T_J = P_D \times (\theta_{JC} + \theta_{interface} + \theta_{Heatsink});$$

Also one can see from the above, it is important to choose an heatsink with adequate size and thermal resistance, such that to maintain the regulator's junction temperature below the maximum operating temperature.

### Layout guideline

As in any switching regulator, layout is very important. Rapidly switching currents associated with wiring inductance can generate voltage transients which can cause problems. For minimal inductance and ground loops, the wires indicated by **heavy lines** **should be wide printed circuit traces and should be kept as short as possible**. For best results, external components should be located as close to the switcher IC as possible using ground plane construction or single point grounding.

If **open core inductors are used**, special care must be taken as to the location and positioning of this type of inductor. Allowing the inductor flux to intersect sensitive feedback, IC ground path and COUT wiring can cause problems.

When using the adjustable version, special care must be taken as to the location of the feedback resistors and the associated wiring. Physically locate both resistors near the IC, and route the wiring away from the inductor, especially an open core type of inductor. (See application section for more information.)

### PACKAGE DIMENSION

#### TO-220 (N220)

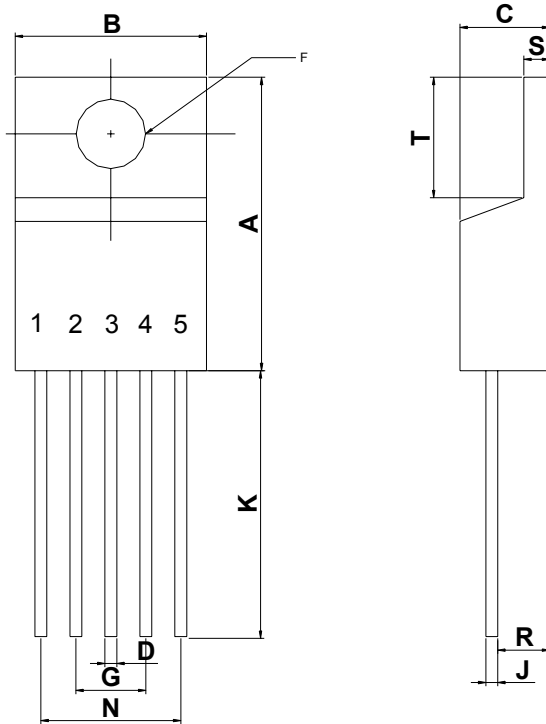

SYMBOLS	DIMENSIONS IN MILLIMETERS			DIMENSIONS IN INCHS		
	MIN	NOM	MAX	MIN	NOM	MAX
A	14.23	---	16.51	0.560	---	0.650
B	9.66	---	10.66	0.380	---	0.420
C	3.56	---	4.82	0.140	---	0.190
D	0.46	---	0.89	0.018	---	0.035
F	3.56	---	4.06	0.140	---	0.160
G	3.40	---	---	0.134	---	---
J	0.31	---	1.14	0.012	---	0.045
K	12.70	---	14.70	0.500	---	0.580
N	---	6.80	---	---	0.268	---
R	2.04	---	2.92	0.080	---	0.115
S	1.14	---	1.39	0.045	---	0.055
T	5.85	---	6.85	0.230	---	0.270

#### TO-263 (N263)

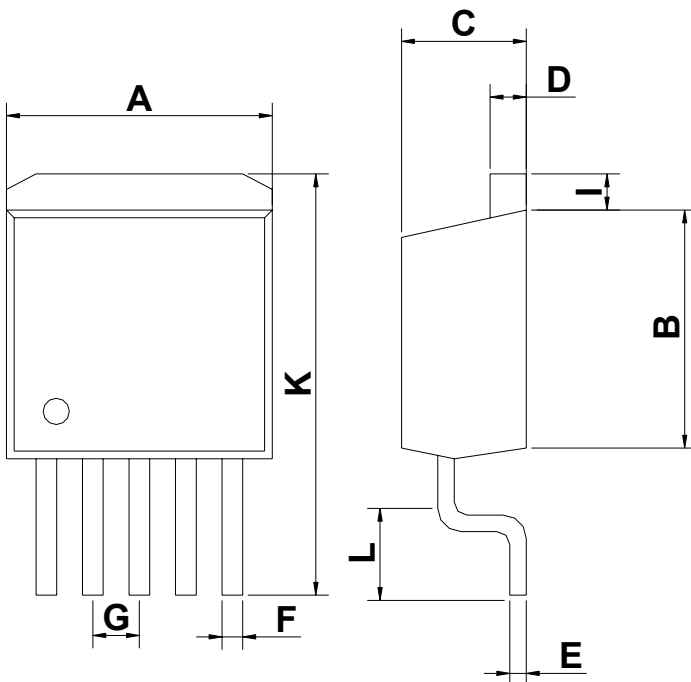

SYMBOLS	DIMENSIONS IN MILLIMETERS			DIMENSIONS IN INCHS		
	MIN	NOM	MAX	MIN	NOM	MAX
A	10.03	---	10.67	0.395	---	0.420
B	8.25	---	9.17	0.325	---	0.361
C	4.34	---	4.59	0.171	---	0.181
D	1.14	---	1.40	0.045	---	0.055
E	0.33	---	0.432	0.013	---	0.017
F	0.737	---	0.889	0.029	---	0.035
G	1.57	---	1.83	0.062	---	0.072
I	---	---	1.65	---	---	0.065
K	14.60	---	16.13	0.575	---	0.635
L	2.29	---	2.79	0.090	---	0.110
V	1.14	---	1.40	0.045	---	0.055

**IMPORTANT NOTICE**

Champion Microelectronic Corporation (CMC) reserves the right to make changes to its products or to discontinue any integrated circuit product or service without notice, and advises its customers to obtain the latest version of relevant information to verify, before placing orders, that the information being relied on is current.

A few applications using integrated circuit products may involve potential risks of death, personal injury, or severe property or environmental damage. CMC integrated circuit products are not designed, intended, authorized, or warranted to be suitable for use in life-support applications, devices or systems or other critical applications. Use of CMC products in such applications is understood to be fully at the risk of the customer. In order to minimize risks associated with the customer's applications, the customer should provide adequate design and operating safeguards.

**HsinChu Headquarter**

---

5F, No. 11, Park Avenue II,  
Science-Based Industrial Park,  
HsinChu City, Taiwan  
TEL: +886-3-567 9979  
FAX: +886-3-567 9909

**Sales & Marketing**

---

11F, No. 306-3, SEC. 1, Ta Tung Road,  
Hsichih, Taipei Hsien 221, Taiwan  
TEL: +886-2-8692 1591  
FAX: +886-2-8692 1596

---