

Low Noise Charge Pump/Linear Regulator LED Driver

Features

- Low noise regulator with integrated charge pump voltage-booster
- 5V output with input voltage as low as 2.8V
- Charge pump can also power an external LDO
- Low noise in 20Hz to 20kHz audio band
- Up to 200mA continuous output current
- Low operating and shutdown currents
- Stable with low-ESR ceramic or tantalum capacitors
- Over-current and over-temperature protection
- 10-lead TDFN package, 3mm x 3mm
- Lead-free versions available

Applications

- White backlight LEDs for main display in wireless handsets and LCD modules
- Power flash LEDs for camera phones
- 3.3V to 5V conversion in PCMCIA cards, PCI Express Cards, other applications needing 5V
- 5V analog supply for audio codec in notebook computers, PDAs, MP3 players, etc

Product Description

The CM4072 Low-noise Charge Pump / LDO Regulator is designed to power white backlight LEDs used in main displays or camera flash LEDs in wireless handsets. The 5V output provides up to 100mA continuous current for input voltages from 3.0V to 5.5V, and up to 200mA for a narrower range. This is accomplished with an integrated charge pump that boosts the input voltage before feeding it to an internal LDO linear regulator. The CM4072 operates with excellent power supply ripple rejection while maintaining good power efficiency. The device utilizes two external capacitors and operates at 250kHz. Separate analog and digital ground pins are provided for the charge pump and the rest of the circuitry to eliminate ground noise feed-through from the charge pump to the regulated output.

The CM4072 provides both overcurrent and thermal overload protection. Two enable inputs provide flexibility in powering down the device. To maximize power saving in shutdown mode, both enable inputs should be at a logic low level. For applications that require the 5V output to be re-established with minimum delay after shutdown, the charge pump can be left enabled while the regulator is disabled. The CMOS LDO regulator features low quiescent current even at full load, making it very suitable for power sensitive applications.

A bypass pin is provided to further minimize noise by connecting an external capacitor between this pin and ground.

The CM4072 is available in a 10-lead TDFN package, with optional lead-free finishing, and is ideal for space critical applications.

Typical Application

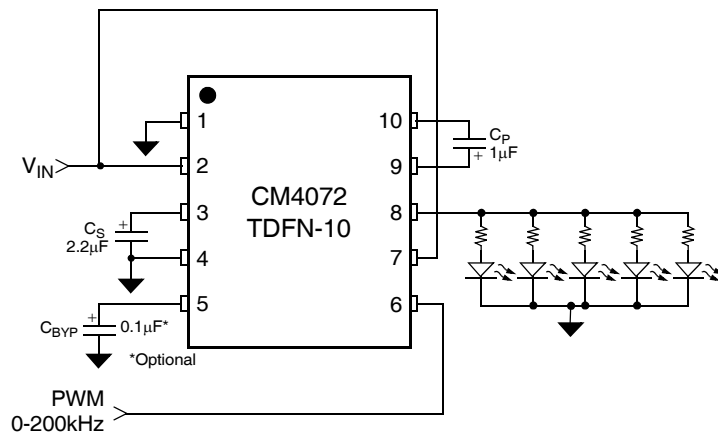

Simplified Block Diagram

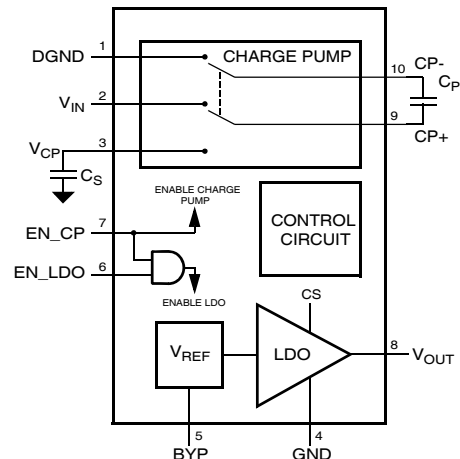

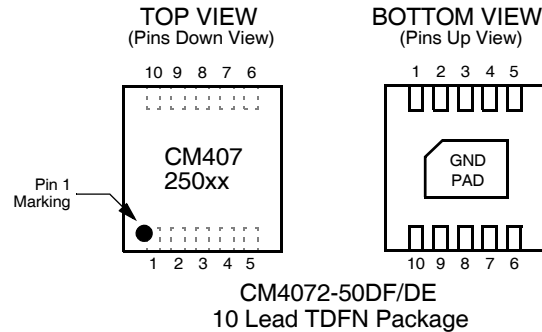
PACKAGE / PINOUT DIAGRAM

Note: This drawing is not to scale.

PIN DESCRIPTIONS

LEAD(S)	NAME	DESCRIPTION																				
1	DGND	Ground for the charge pump circuit. This should be connected to the system (noisy) ground.																				
2	V_{IN}	Input power source for the device. Since the charge pump draws current in pulses at the 250kHz internal clock frequency, a low-ESR input decoupling capacitor is usually required close to this pin to ensure low noise operation.																				
3	V_{CP}	Charge pump output which is connected to the external reservoir capacitor C_S . This should be a low-ESR capacitor. When the voltage on this pin reaches about 5.8V then the charge pump pauses until the voltage on this pin drops to about 5.7V. This gives rise to at least 100mV of 'ripple' (the frequency and amplitude of this ripple depends upon values of C_P and C_S and also the ESR of C_S).																				
4	GND	Ground reference for all internal circuits except the charge pump. This pin should be connected to a "clean" low-noise analog ground																				
5	BYP	Bypass input connected to the internal voltage reference of the LDO regulator. An external bypass capacitor C_{BYP} of 0.1uF is recommended to minimize internal voltage reference noise and maximize power supply ripple rejection.																				
6, 7	EN_LDO, EN_CP	EN_LDO (pin 6) and EN_CP (pin 7) are active-high TTL-level logic inputs to enable the linear regulator and charge pump according to the following truth table: <table border="1" style="margin: 10px auto;"> <thead> <tr> <th>EN_CP (Pin 7)</th> <th>EN_LDO (Pin 6)</th> <th>CHARGE PUMP</th> <th>REGULATOR</th> </tr> </thead> <tbody> <tr> <td>1</td> <td>1</td> <td>Enabled</td> <td>Enabled</td> </tr> <tr> <td>1</td> <td>0</td> <td>Enabled</td> <td>Disabled</td> </tr> <tr> <td>0</td> <td>1</td> <td>Disabled</td> <td>Disabled</td> </tr> <tr> <td>0</td> <td>0</td> <td>Disabled</td> <td>Disabled</td> </tr> </tbody> </table>	EN_CP (Pin 7)	EN_LDO (Pin 6)	CHARGE PUMP	REGULATOR	1	1	Enabled	Enabled	1	0	Enabled	Disabled	0	1	Disabled	Disabled	0	0	Disabled	Disabled
EN_CP (Pin 7)	EN_LDO (Pin 6)	CHARGE PUMP	REGULATOR																			
1	1	Enabled	Enabled																			
1	0	Enabled	Disabled																			
0	1	Disabled	Disabled																			
0	0	Disabled	Disabled																			
8	V_{OUT}	The regulated output. An output capacitor may be added to improve noise and load-transient response. When the LDO regulator is disabled, an internal pull-down with a nominal resistance of 50 ohms is activated to discharge the V_{OUT} rail to GND																				
9, 10	CP+, CP-	CP+ (pin 9) and CP- (pin 10) are used to connect the external "flying" capacitor C_P to the charge pump. The charge stored in C_P is transferred to the reservoir capacitor C_S at the 250kHz internal clock rate.																				

Ordering Information

PART NUMBERING INFORMATION					
Leads	Package	Standard Finish		Lead-free Finish	
		Ordering Part Number ¹	Part Marking	Ordering Part Number ¹	Part Marking
10	TDFN-10	CM4072-50DF	CM407 250DF	CM4072-50DE	CM407 250DE

Note 1: Parts are shipped in Tape & Reel form unless otherwise specified.

Specifications

ABSOLUTE MAXIMUM RATINGS		
PARAMETER	RATING	UNITS
ESD Protection (HBM)	±2000	V
V _{EN} Logic Input Voltage	(V _{IN} + 0.5) to (GND - 0.5)	V
V _{IN} , V _{OUT} Pin Voltages	+5.5 to (GND - 0.5)	V
Storage Temperature Range	-65 to +150	°C
Operating Temperature Range		
Ambient	-40 to +85	°C
Junction	-40 to +150	°C

STANDARD OPERATING CONDITIONS		
PARAMETER	VALUE	UNITS
Input Voltage Range (V _{IN})	2.8 to 5.5	V
Ambient Operating Temperature	-40 to +85	°C
θ _{JA} of TDFN package on PCB	200 (approx.)	°C/W
Output Load Current (I _{OUT})	0 to 200	mA
C _{BYP}	0.1	μF
C _{OUT}	0 to 100	μF

RECOMMENDED EXTERNAL COMPONENTS		
DEVICE	VALUE	UNITS
C _S	2.2	μF
C _P	1.0	μF

Specifications (cont'd)

ELECTRICAL OPERATING CHARACTERISTICS (SEE NOTE 1)						
SYMBOL	PARAMETER	CONDITIONS	MIN	TYP	MAX	UNITS
V_{CP}	Charge Pump Output Voltage	$V_{OUT} = 5V, 1mA \leq I_{OUT} \leq 100mA$	5.5	5.8	7	V
V_{OUT}	Regulator Output Voltage	$V_{IN} = 4.0V, 1mA \leq I_{OUT} \leq 100mA$	4.85		5.15	V
$V_{R\ LOAD}$	Load Regulation	$I_{OUT} = 1mA$ to 100mA		0.2		%
$V_{R\ LINE}$	Line Regulation	Vary V_{IN} from 3.0V to 5.0V		0.02		%
R_{DISCHG}	V_{OUT} Discharge Resistance	LDO regulator disabled, EN_LDO grounded, $V_{IN} = 5V$		500		Ω
I_{GND}	LDO Regulator Ground Current via the GND pin	Shutdown (EN_LDO grounded)		1	10	μA
		Regulator Enabled, $I_{OUT} = 0mA$		180		μA
		Regulator Enabled, $I_{OUT} = 100mA$		180		μA
I_{DGND}	Charge Pump Shutdown Current via DGND pin	EN_CP grounded, $V_{IN} = 5V$		1	10	μA
PSRR	Power Supply Ripple Rejection	$I_{OUT} = 100mA, C_{BYP} = 0.1\mu F$, Note 2 $f = 100Hz$		42		dB
		$f = 10kHz$		42		dB
e_{NO}	Output Voltage Noise	BW=22Hz-22kHz, $C_{OUT} = 10\mu F$, $C_{BYP} = 0.1\mu F, I_{OUT} = 100mA$, Note 2		35		μV_{rms}
		BW=22Hz-22kHz, $C_P = 1\mu F, C_S = 3\mu F$, $C_{OUT} = C_{BYP} = 0.1\mu F, I_{OUT} = 100mA$, Note 2		38		μV_{rms}
V_{IH}	EN_CP, EN_LDO Input High Threshold	$V_{IN} = 5.0V$	2.0			V
V_{IL}	EN_CP, EN_LDO Input Low Threshold	$V_{IN} = 5.0V$			0.5	V
I_{LIM}	Overload Current Limit	LDO Only, Note 2	200	300		mA
I_{SC}	Output Short Circuit Current	LDO Only, Note 2		50		mA
T_{JSD}	Thermal Shutdown Junction Temperature			170		$^{\circ}C$
T_{HYS}	Thermal Shutdown Hysteresis			25		$^{\circ}C$

Note 1: Unless otherwise noted, electrical operating characteristics are specified with $T_A = 0$ to $70^{\circ}C$, $V_{IN} = 5.0V$, $I_{OUT} = 100mA$, $C_{OUT} = 10\mu F$, $C_P = 1\mu F$, $C_S = 10\mu F$.

Note 2: These parameters are guaranteed by design and characterization.

Performance Information

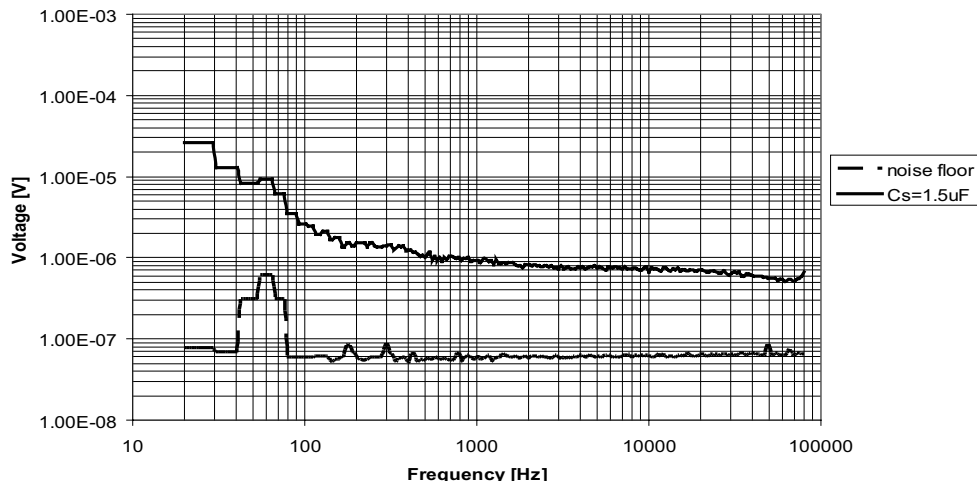

Note: Noise peaks may appear for different values of C_P , C_S & I_{OUT} , and are due to the ripple frequency of the charge pump (see later).

Figure 1. CM4072 Noise Spectrum ($T_A = 25^\circ\text{C}$, $C_P=0.47\mu\text{F}$, $C_S = 1.5\mu\text{F}$, $C_{OUT} = 10\mu\text{F}$, $C_{BYP} = 0.1\mu\text{F}$, $I_{OUT} = 100\text{mA}$)

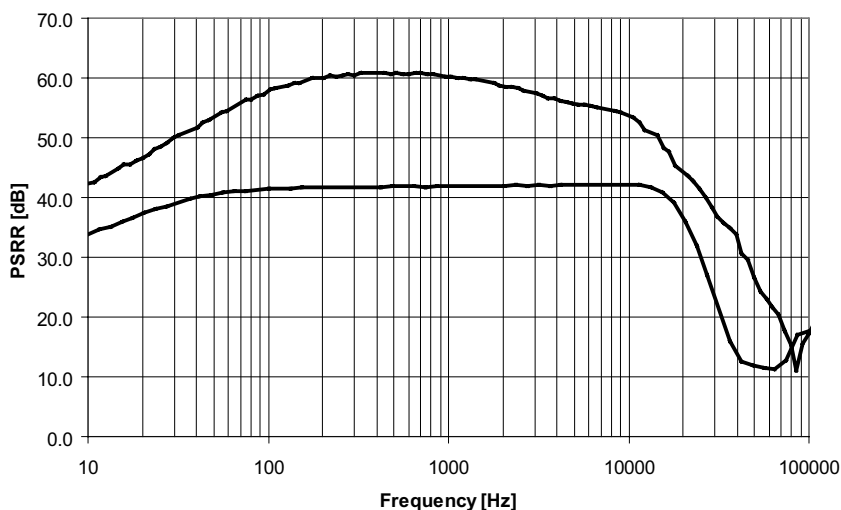

Measured by forcing V_{IN} voltage to 3.3V & 5.0V dc, then sweeping 100mV ac on V_{IN} . $C_{OUT} = 10\mu\text{F}$, $C_{BYP} = 0.1\mu\text{F}$.

Figure 2. CM4072 PSRR (upper curve with $V_{IN} = 3.3\text{V}$, lower curve with $V_{IN} = 5\text{V}$, $I_{OUT} = 100\text{mA}$ both cases)

Performance Information (cont'd)

Typical DC Characteristics ($T_A=25^\circ\text{C}$, $C_P=1.0\mu\text{F}$, $C_S=10\mu\text{F}$, $C_{BYP}=0.1\mu\text{F}$, $C_{OUT}=10\mu\text{F}$ unless otherwise noted)

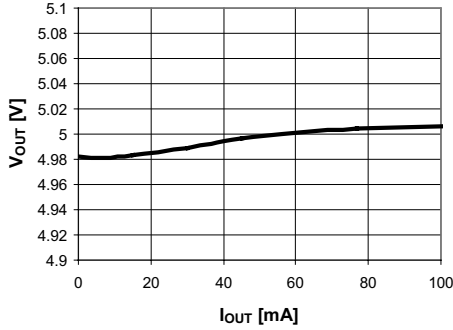

Figure 3. V_{OUT} vs. I_{OUT} ($V_{IN} = 5\text{V}$)

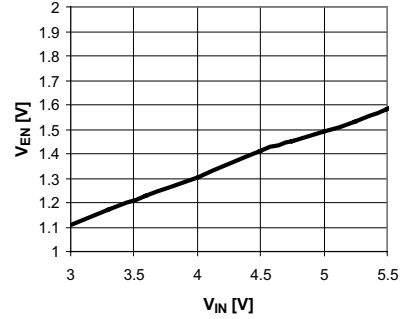

Figure 7. V_{EN} Threshold vs. V_{IN}

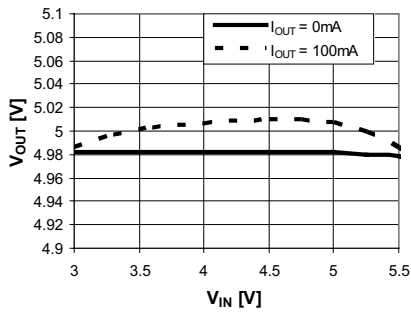

Figure 4. V_{OUT} vs. V_{IN}

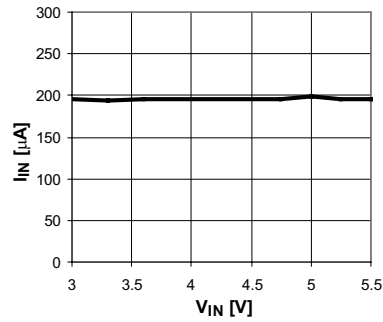

Figure 8. I_{IN} vs. V_{IN}

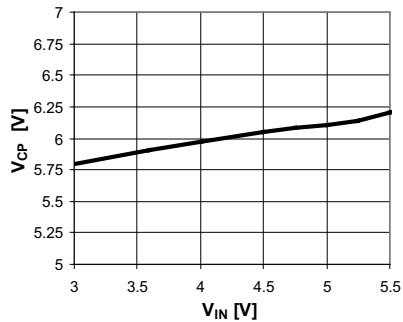

Figure 5. CS Pin vs. V_{IN}

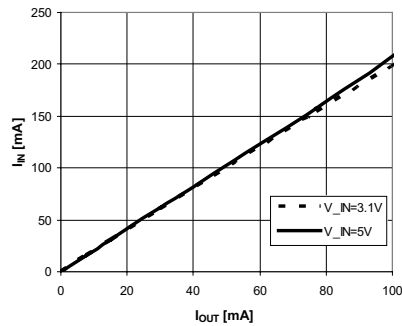

Figure 9. I_{IN} vs. I_{OUT}

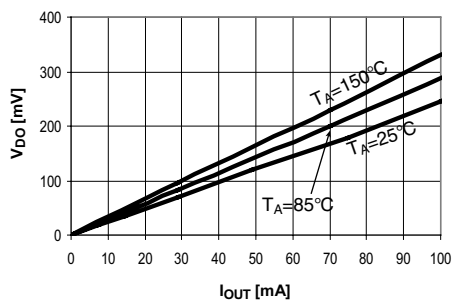

Figure 6. Dropout Voltage (LDO Only)

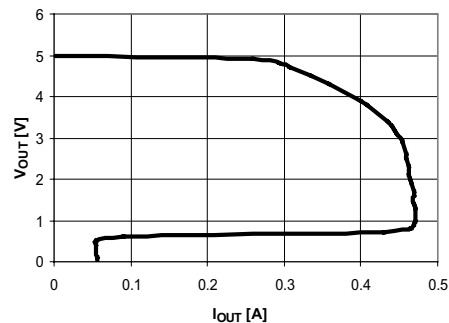

Figure 10. Overcurrent Characteristic (LDO only)

Performance Information (cont'd)

Transient Characteristics ($T_A=25^{\circ}\text{C}$, $C_P=1.0\mu\text{F}$, $C_S=10\mu\text{F}$, $C_{BYP}=0.1\mu\text{F}$, $C_{OUT}=10\mu\text{F}$ unless otherwise noted)

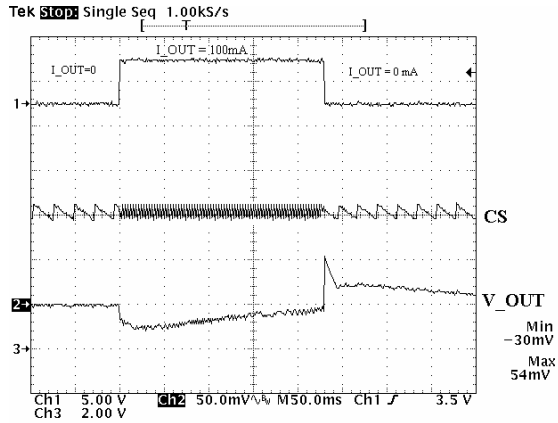

Figure 11. Load Regulation (0mA to 100mA)

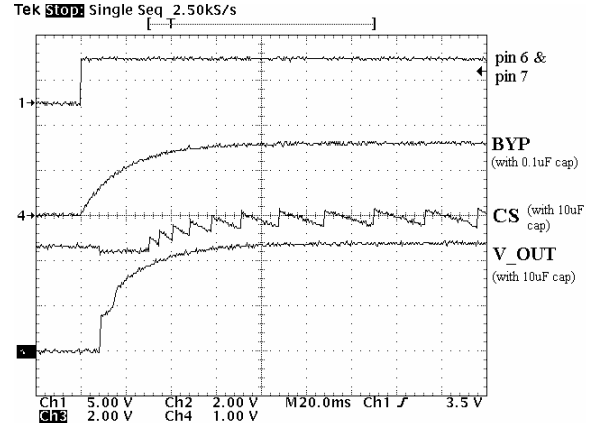

Figure 14. Cold Start / Power-Up

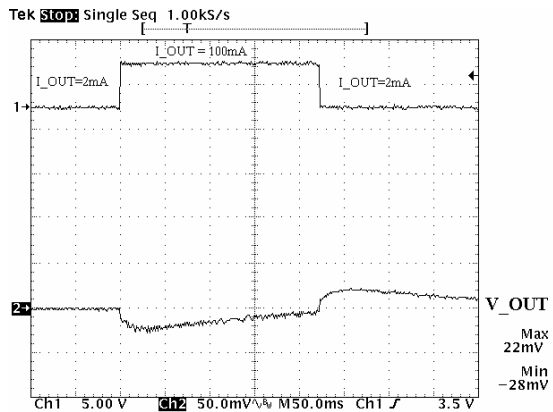

Figure 12. Load Regulation (2mA to 100mA)

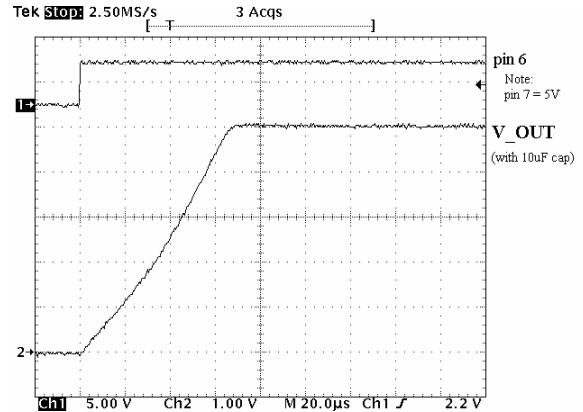

Figure 15. LDO Power-Up

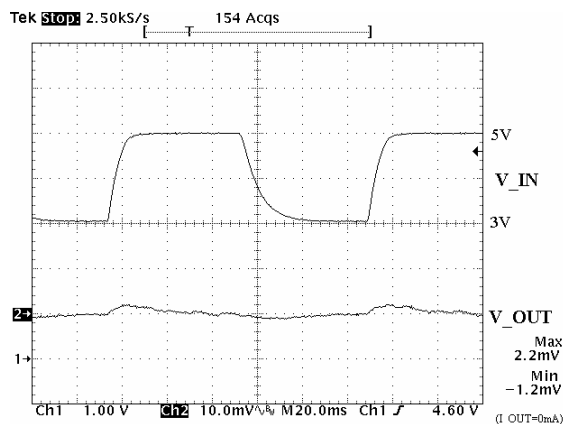

Figure 13. Line Regulation

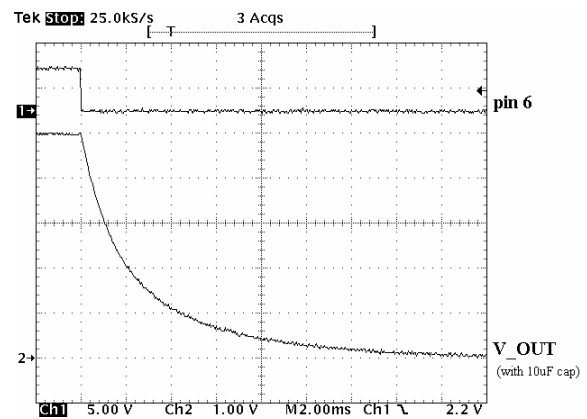

Figure 16. LDO Power-Down

Performance Information (cont'd)

Transient Characteristics ($T_A=25^\circ\text{C}$, $V_{IN}=5\text{V}$, $C_P=1.0\mu\text{F}$, $C_S=10\mu\text{F}$, $C_{BYP}=0.1\mu\text{F}$, $C_{OUT}=10\mu\text{F}$ unless otherwise noted)

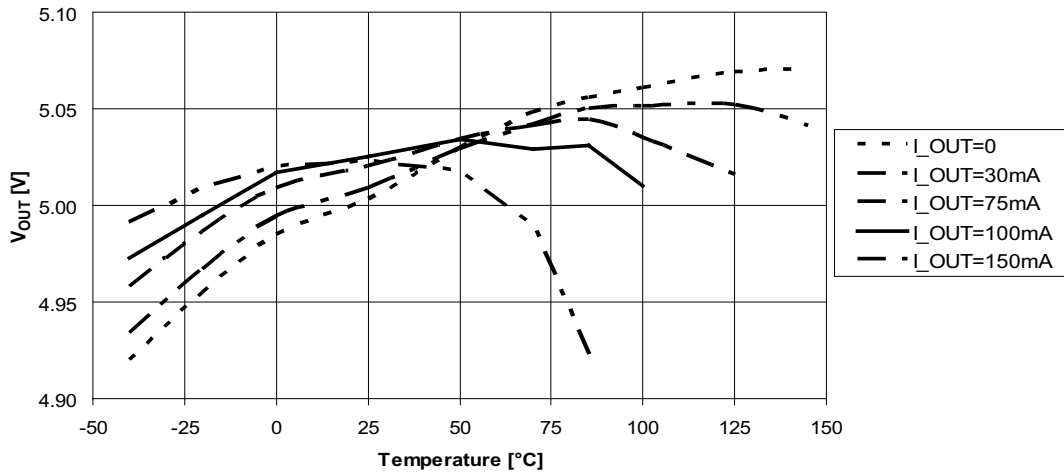

Figure 17. V_{OUT} with $V_{IN} = 5\text{V}$

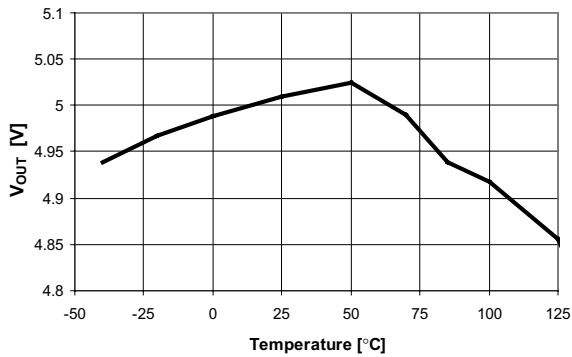

Figure 18. V_{OUT} with $V_{IN}=3.0\text{V}$, $I_{OUT}=100\text{mA}$

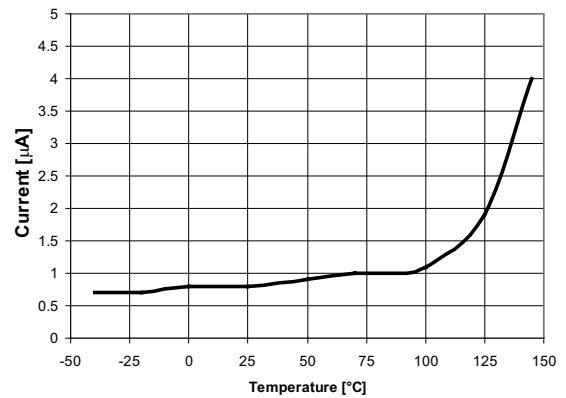

Figure 20. I_{IN} Leakage Current (Pins 6,7=0V)

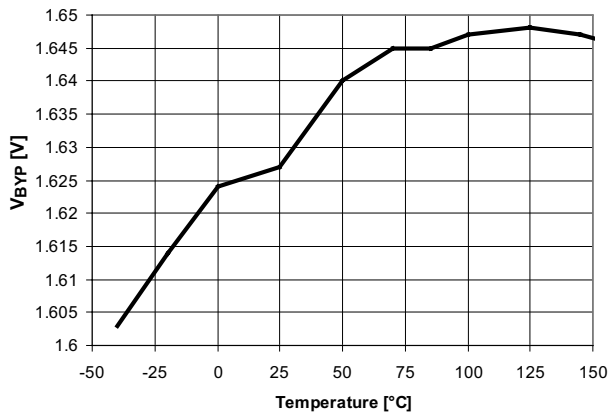

Figure 19. Bypass Pin Voltage

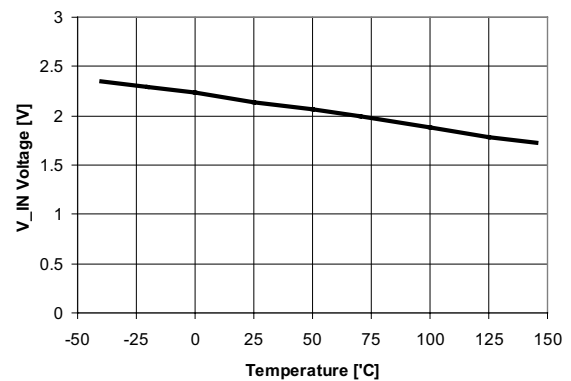

Figure 21. Undervoltage Lockout

Application Information

Ripple Frequency

The charge pump internal oscillation frequency is about 250kHz. However, this is the continuous, free-running frequency, which is usually only seen while the charge pump is powering up. Such a sawtooth 'ripple' waveform on CS can have a much lower frequency than 250kHz. This mode of operation is necessary to conserve power. If it were not done this way, then a much larger package with heatsink would be required.

The frequency of this 'ripple' is affected by V_{IN} , I_{OUT} , C_S capacitor value and C_P capacitor value.

Guidelines for External Capacitors

(1) To find C_P : specify value of V_{IN} , and highest value of I_{OUT} :

If $V_{IN} = 3.3V \pm 5\%$, then minimum value of C_P (μF) = I_{OUT} (mA) / 85.

If $V_{IN} = 5.0V \pm 10\%$, then minimum value of C_P (μF) = I_{OUT} (mA) / 700

(2) The V_{IN} decoupling capacitor, C_{IN} , should typically be much greater than C_P to prevent voltage droop during C_P charging. Excessive glitches on V_{IN} will affect the output voltage V_{OUT} . C_{IN} is typically 10X greater than C_P .

(3) C_S should be small to ensure that the ripple frequency is high, but at least 2x greater than C_P , otherwise the ripple amplitude will be very high. Reducing the value of C_S will increase the ripple frequency.

Examples of C_S ripple frequencies ($C_S=10\mu F$, $T_A=25^\circ C$) are shown in following tables:

$C_P = 0.47\mu F$		
V_{IN}	I_{OUT}	C_S Frequency
3.14	15mA	46kHz
3.60	15mA	35kHz
4.50	70mA	76kHz
5.50	70mA	56kHz

$C_P = 1.0\mu F$		
V_{IN}	I_{OUT}	C_S Frequency
3.14	100mA	250kHz
3.60	100mA	110kHz
4.50	100mA	67kHz
5.50	100mA	49kHz

(4) C_{OUT} , the optional V_{OUT} capacitor, helps minimize noise and improve load regulation; 0.1 μF to 100 μF is recommended.

(5) C_{BYP} , the optional bypass capacitor helps reduce noise in the LDO; 0.1 μF is recommended.

After choosing external component values, check in-system performance (at min/max V_{IN} , max temperature, and min/max I_{OUT}). See the troubleshooting guide on next page for tips if there are problems.

Charge Pump Noise

The charge pump is 'digital' in operation and can produce digital noise at both the free-running frequency and at the ripple frequency.

To minimize noise, PCB grounding is important! This part requires short, low-impedance ground connections for DGND (pin 1), GND (pin 4), the V_{IN} decoupling capacitor (pin 2), the C_S capacitor (pin 3), the Bypass decoupling capacitor (pin 5) and the V_{OUT} decoupling capacitor (pin 8). All decoupling capacitors and the C_S capacitor should be low-ESR ceramics. The C_P capacitor needs to be low-ESR.

Efficiency

The power efficiency in % of the combined charge pump and LDO is approximately:

$$100 \times (V_{OUT}) / (V_{IN} \times 2)$$

Power Dissipation

The dissipation of the part is approximately:

$$((V_{IN} \times 2) - V_{OUT}) \times I_{OUT}$$

The TDFN-10 package heats at a rate of about $200^{\circ}\text{C}/\text{W}$ (θ_{JA}). Note that this value is approximate because it depends upon the copper tracks and ground planes on the pcb. If $V_{IN} = 5\text{V}$ and $I_{OUT} = 100\text{mA}$ then the power dissipation will be approximately 500mW . Multiplying this by the θ_{JA} gives an internal temperature about 100°C higher than the ambient temperature (T_A). If the T_A is 70°C then the internal temperature will be approximately 170°C which will trigger the overtemperature circuit and lead to power-down.

$$\text{Internal temperature} = \text{Ambient temperature} + (\theta_{JA} \times \text{Power dissipation})$$

(Must be less than 170°C)

Note that the evaluation PCB has a θ_{JA} of less than $150^{\circ}\text{C}/\text{W}$, based upon measured performance.

How to Reduce the Power Dissipation of the Part and How to Get More Than 100mA

If $V_{IN} = 5\text{V}$ typ., then the charge pump / LDO combination is capable of providing more than 100mA . The only problem is power dissipation.

If the input voltage is lowered using an external diode then the output current can be increased without causing the part to overheat. The circuit below illustrates an example of how to increase the output current.

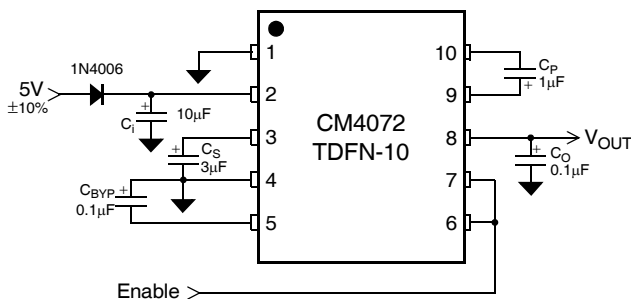

Using this circuit, I_{OUT} can be 200mA if $V_{IN} = 4.75\text{V}$, and yet the part will not overheat even if $V_{IN} = 5.25\text{V}$, $I_{OUT}=200\text{mA}$ and the ambient temperature is 85°C .

Warnings

The charge pump output V_{CP} (pin 3) must not be shorted to GND or held below its internally-set voltage while the part is powered. This usually results in the destruction of the part.

With $V_{IN} = 5\text{V}$, the maximum current that can be continuously drawn from V_{CP} is approximately 100mA dc.

Never short C_{P+} (pin 9) to C_{P-} (pin 10). This will cause large currents to flow from V_{IN} to DGND through the part, usually causing its destruction. This will happen even if EN_CP and EN_LDO are off.

Troubleshooting Guide

1) *Is the output voltage drooping under heavy loads?* Perhaps the charge pump cannot provide the necessary current. Try increasing the value of C_P . If that does not work, then, is V_{IN} too low? Is V_{IN} dropping during the C_P charging cycle? If V_{IN} is not suitably decoupled and drops below 3.1V then the available current will be very low.

2) *Is the output voltage oscillating between 5V and 0V?* The part may be reaching its overtemperature limit. Reduce current consumption, reduce θ_{JA} or add an external diode on the input to reduce V_{IN} .

3) *Is the part too noisy?* Try increasing the value (or reducing ESR) of C_S , C_{IN} , C_S , C_B . At minimum current the charge pump ripple frequency will be low. If V_{OUT} noise is at the charge pump ripple frequency, then change values of C_P and C_S . Reducing the input voltage V_{IN} will reduce the charge pump ripple frequency noise on V_{OUT} .

4) *Will the part power up?* Pin 6 must be HIGH to power up. Even if pin 7 is HIGH, pin 6 must also be high to power up.

5) *Can the cold start power-up time be reduced?* Yes, by reducing the value of the C_{BYP} .

Mechanical Details

TDFN-10 Mechanical Specifications

Dimensions for the CM4072-50DF/DE supplied in a 10-lead TDFN package are presented below.

For complete information on the TDFN-10, see the California Micro Devices TDFN Package Information document.

PACKAGE DIMENSIONS						
Package	TDFN					
JEDEC No.	MO-229 (Var. WEED-3) [†]					
Leads	10					
Dim.	Millimeters			Inches		
	Min	Nom	Max	Min	Nom	Max
A	0.70	0.75	0.80	0.028	0.030	0.031
A1	0.00	0.02	0.05	0.000	0.001	0.002
A2	0.45	0.55	0.65	0.018	0.022	0.026
A3		0.20			0.008	
b	0.18	0.25	0.30	0.007	0.010	0.012
D		3.00			0.118	
D2	2.20	2.30	2.40	0.087	0.091	0.094
E		3.00			0.118	
E2	1.40	1.50	1.60	0.055	0.060	0.063
e		0.50			0.020	
K	0.20			0.008		
L	0.20	0.30	0.40	0.008	0.012	0.016
# per tape and reel	3000 pieces					
Controlling dimension: millimeters						

[†]This package is compliant with JEDEC standard MO-229, variation WEED-3 with exception of the "D2" and "E2" dimensions as called out in the table above.

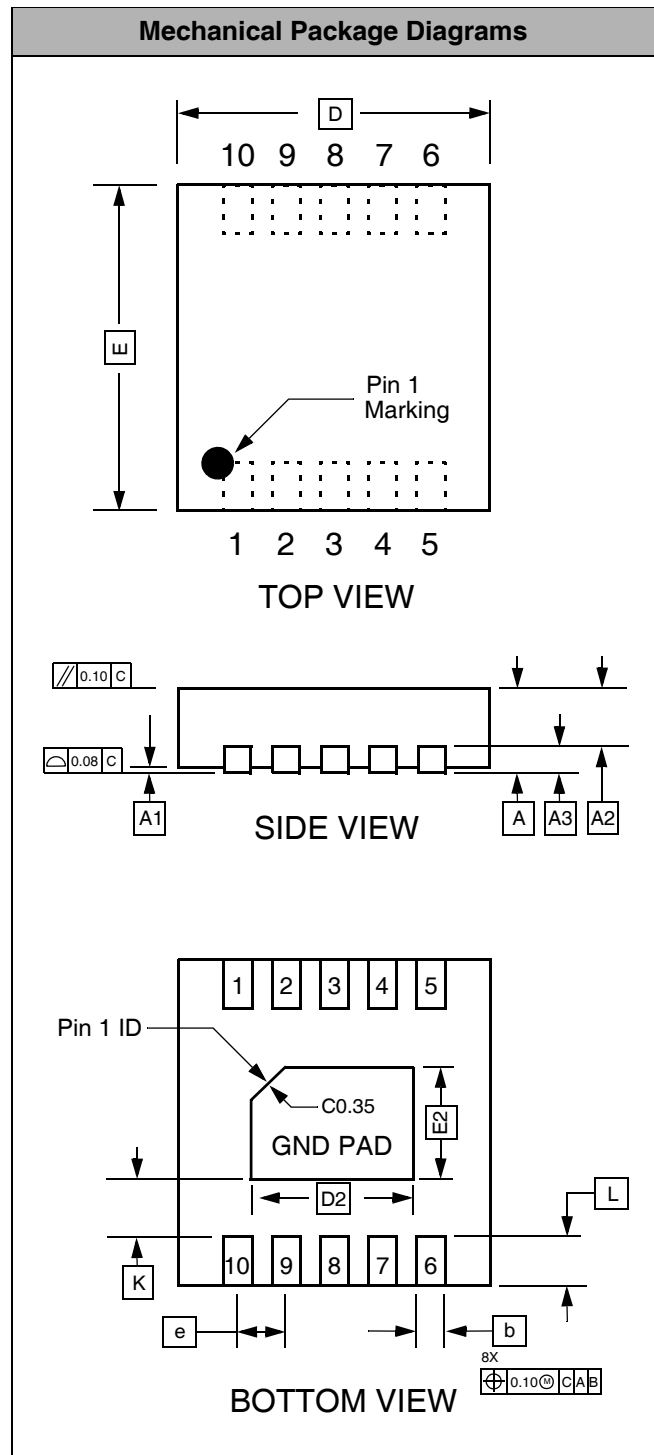

Package Dimensions for 10-Lead TDFN