

# Four-Way 0° Power Splitter Combiner 0.81–0.96 GHz



PD4W09-12

## Features

- Low Cost
- Low Profile
- Available in Small SOIC-8 Package
- Tape & Reel

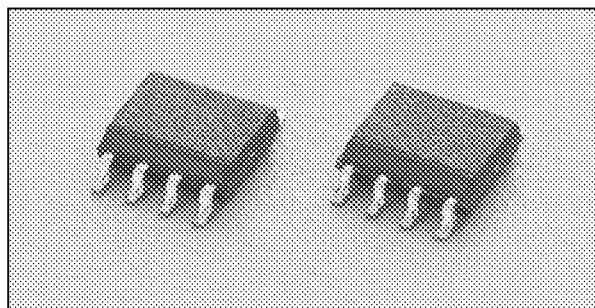

## Description

The PD4W09-12 is a monolithic four-way in-phase hybrid junction tuned for the 0.81–0.96 GHz band. It offers low loss, high isolation, good input/output matching and exceptional phase/amplitude balance. It is available in the SOIC-8 leaded surface mount package.

## Electrical Specifications at 25°C

Parameter	Min.	Typ.	Max.	Unit
Frequency	0.81		0.96	GHz
Insertion Loss Less 6 dB Split		1.3	1.5	dB
Isolation	20	23		dB
Input VSWR		1.2:1	1.5:1	
Output VSWR		1.2:1	1.5:1	
Amplitude Balance		±0.4	±0.6	dB
Phase Balance		±6	±8	Deg.

## Pin Out

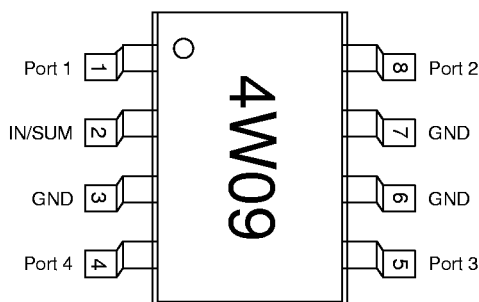

## Block Diagram

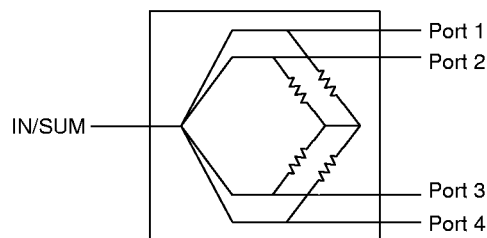

Performance Data

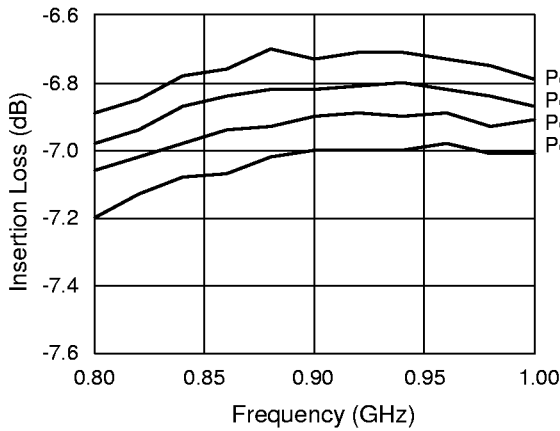

Insertion Loss vs. Frequency

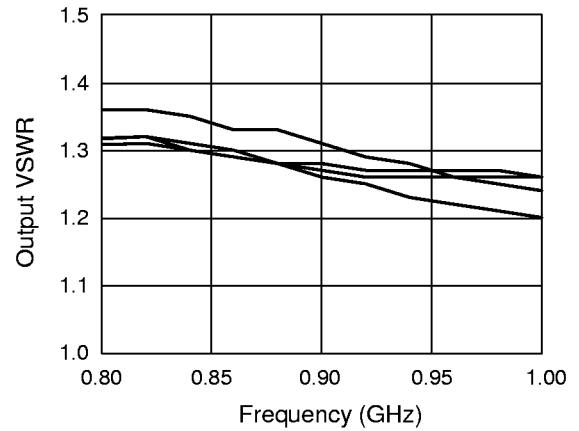

Output VSWR vs. Frequency

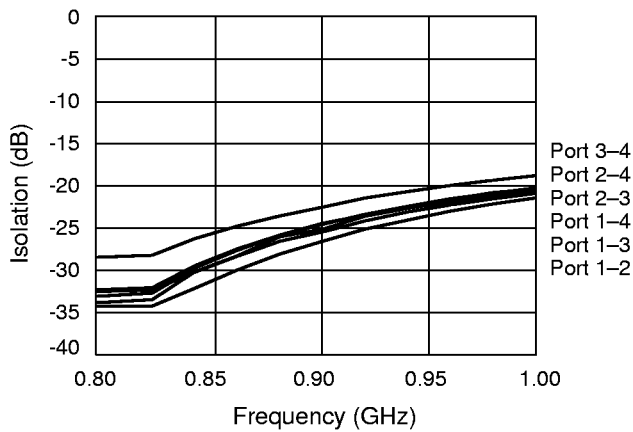

Isolation vs. Frequency

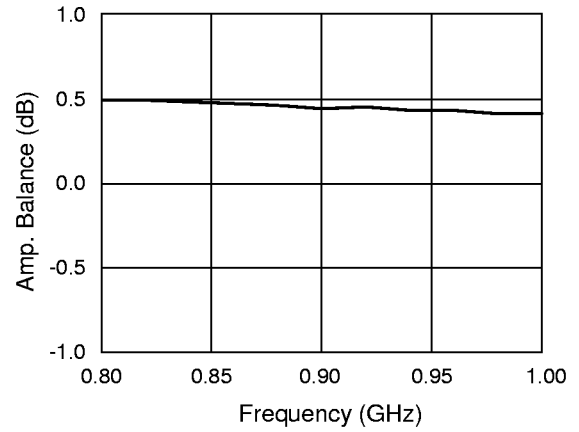

Amp. Balance vs. Frequency

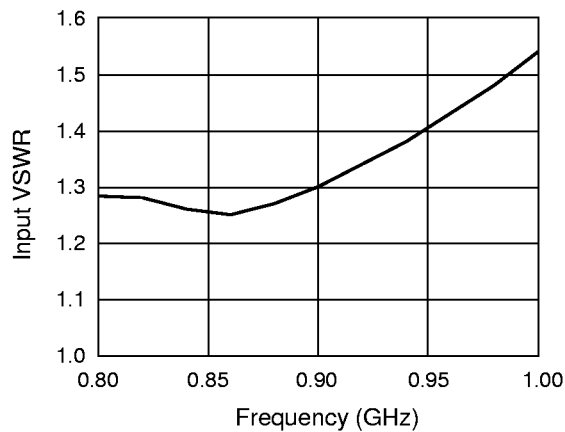

Input VSWR vs. Frequency

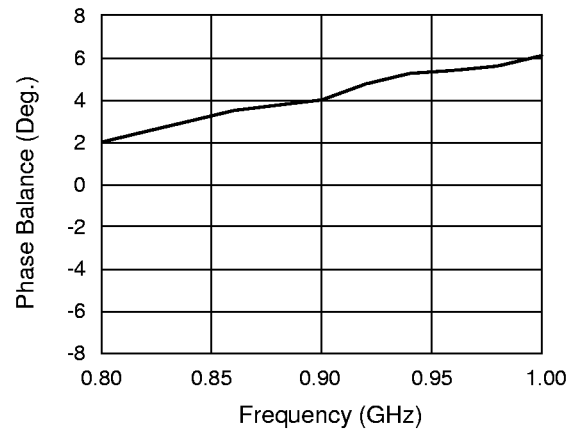

Phase Balance vs. Frequency

### Absolute Maximum Ratings

Characteristic	Value
Input Power <sup>1</sup>	1.5 W CW
Input Power <sup>2</sup>	0.375 CW
Operating Temperature	-40°C to 85°C
Storage Temperature	-65°C to 150°C

1. When used as a power divider with a 2.0:1 maximum VSWR on all ports.
2. When used as a power combiner with a 2.0:1 maximum VSWR on all ports.

### Recommended Board Layout

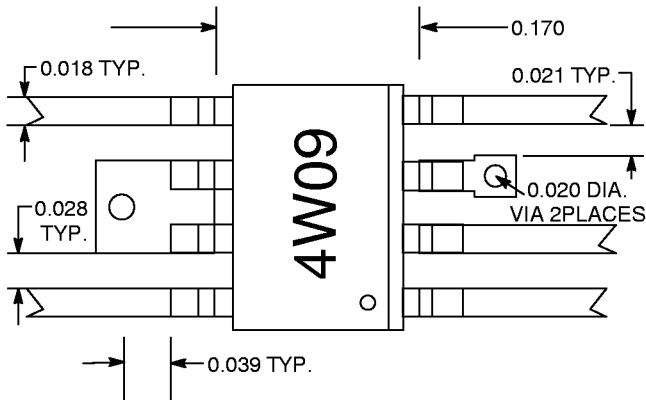

Material is 10 mil FR4

### SOIC-8

