

CeraDiode®

Reliable ESD protection of single lines

Description

Due to the ongoing miniaturization, today's electronic devices are more and more sensitive to electrostatic discharges (ESD) and overvoltages. Therefore reliable protection components become absolutely necessary to harden your valuable electronics against the impact of ESD.

CeraDiodes are ceramic semiconductors optimized specifically for high performance in Electro Static Discharge (ESD) applications. The device has a non-linear voltage/current characteristic that is highly optimized for effectively suppressing extremely fast voltage transients. The device offers superior parametric stability over the complete operating range of $-40\text{ }^{\circ}\text{C}$ to $+85\text{ }^{\circ}\text{C}$.

CeraDiodes are bi-directional devices. A single CeraDiode® connected from signal/dataline to ground routes both positive and negative ESD transitions safely to the ground plane. This technique eliminates the need to route ESD charge into the power plane, possibility damaging nearby integrated circuits.

Features

- ESD protection according to IEC 61000-4-2 (Level 4)
- Endurance specification up to 3000 ESD pulses (IEC 61000-4-2 Level 4)
- Suitable for uni- and bidirectional lines
- Bidirectional ESD protection in a two-pin device
- Routes all ESD events, both positive and negative, safely to ground
- Suitable for DC working voltages up to 22 V
- No derating of maximum ratings up to 85 °C
- Surface mount package in 0603 case size
- Extremely fast response time $< 0.5\text{ ns}$
- Lead free nickel barrier terminations

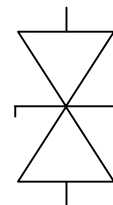

Application

- Desktop and notebook computers
- Peripherals
- Portable handheld products (e.g. PDA)
- Mobile communication
- Consumer products (set top box, MP3 player, digital cameras,...)
- Liquid crystal displays (LCD) / monitors

ISSUE DATE	07.10.2004	ISSUE	g	PUBLISHER	KB VS PE	PAGE	1/8
------------	------------	-------	---	-----------	----------	------	-----

Application example

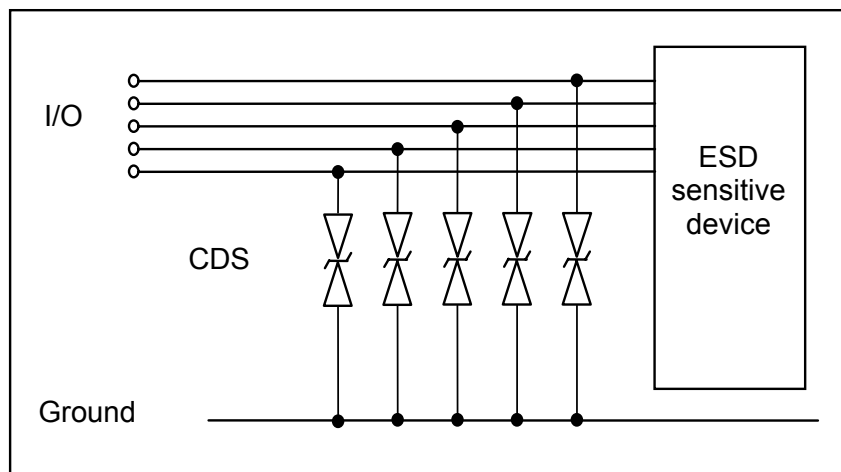

Protection of I/O Lines with discrete CeraDiodes

Maximum ratings ($T_A = 85\text{ °C}$)

Rating	Symb.	Value	Unit
Max. DC working voltage	V_{DC}	CDS3C05GTA: 5.6 CDS3C09GTA: 9.0 CDS3C15GTA: 16.0 CDS3C20GTA: 22.0	V
Peak current @ 8/ 20 μ s	I_{peak}	30	A
Peak pulse power @ 8/ 20 μ s	P_{PP}	CDS3C05GTA: 1000 CDS3C09GTA: 1600 CDS3C15GTA: 2000 CDS3C20GTA: 2200	W
Air discharge ESD capability (according to IEC 61000-4-2 method)	V_{ESD}	15	kV
Contact discharge ESD capability (according to IEC 61000-4-2 method)	V_{ESD}	8	kV
Operating temperature (without derating)	T_j	-40 to +85	°C
Storage temperature	T_{stg}	-40 to +125	°C

Characteristics (T_A = 25 °C)

CDS3C05GTA

Parameter	Symb.	Conditions	Minimum	Typical	Maximum	Unit
Breakdown voltage	V _{BR}	I _{BR} = 1 mA	6.4	-		V
Leakage current ^{*)}	I _L	V _L = 3.3 V	-	-	10	µA
Clamping voltage	V _{CL}	I _{peak} = 1 A, 8/20 µs	-	-	19	V
Capacitance	C	V = 1 V, f = 1 MHz	-	470	-	pF

CDS3C09GTA

Parameter	Symb.	Conditions	Minimum	Typical	Maximum	Unit
Breakdown voltage	V _{BR}	I _{BR} = 1 mA	10	-	-	V
Leakage current ^{*)}	I _L	V _L = 5.6 V	-	-	10	µA
Clamping voltage	V _{CL}	I _{peak} = 1 A, 8/20 µs	-	-	30	V
Capacitance	C	V = 1 V, f = 1 MHz	-	220	-	pF

CDS3C15GTA

Parameter	Symb.	Conditions	Minimum	Typical	Maximum	Unit
Breakdown voltage	V _{BR}	I _{BR} = 1 mA	22	-	-	V
Leakage current ^{*)}	I _L	V _L = 9 V	-	-	10	µA
Clamping voltage	V _{CL}	I _{peak} = 1 A, 8/20 µs	-	-	42	V
Capacitance	C	V = 1 V, f = 1 MHz	-	160	-	pF

CDS3C20GTA

Parameter	Symb.	Conditions	Minimum	Typical	Maximum	Unit
Breakdown Voltage	V _{BR}	I _{BR} = 1 mA	25	-	-	V
Leakage Current ^{*)}	I _L	V _L = 12 V	-	-	10	µA
Clamping Voltage	V _{CL}	I _{peak} = 1 A, 8/20 µs	-	-	50	V
Capacitance	C	V = 1 V, f = 1 MHz	-	56	-	pF

^{*)} Any lower operating voltage than V_L results in a lower leakage current

Typical characteristics

Max. current, energy and average power dissipation
depending on ambient temperature

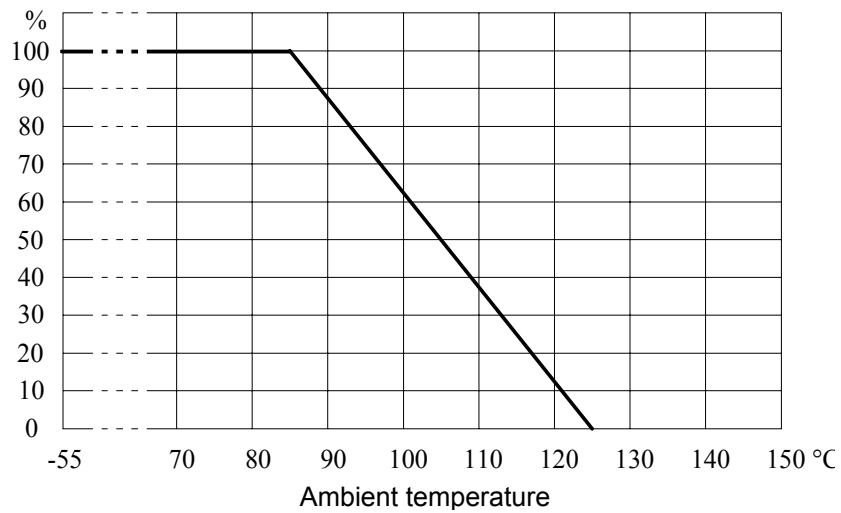

Dimensional drawing

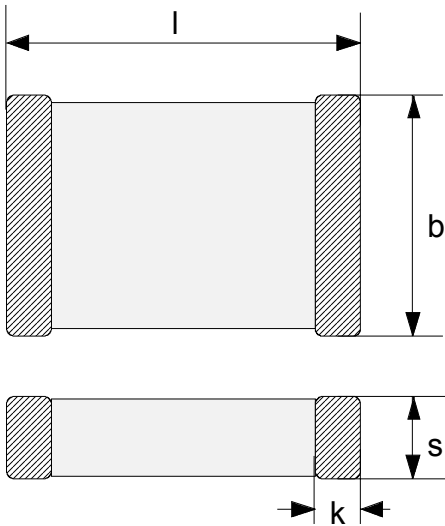

Symb.	Min.	Max.	Unit
l	1.45	1.75	mm
b	0.7	0.9	mm
s	0.7	0.9	mm
k	0.1	0.4	mm

Recommended solder pads

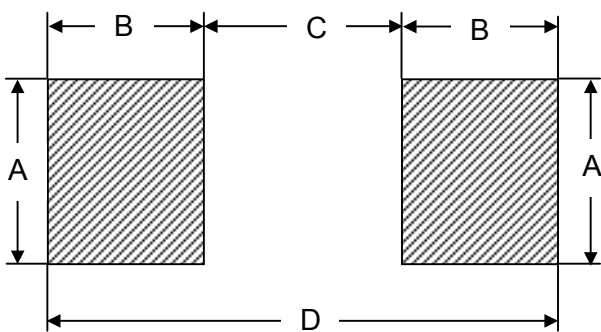

Symb.	Dim.	Unit
A	1.0	mm
B	1.0	mm
C	1.0	mm
D	3.0	mm

Recommended soldering profiles

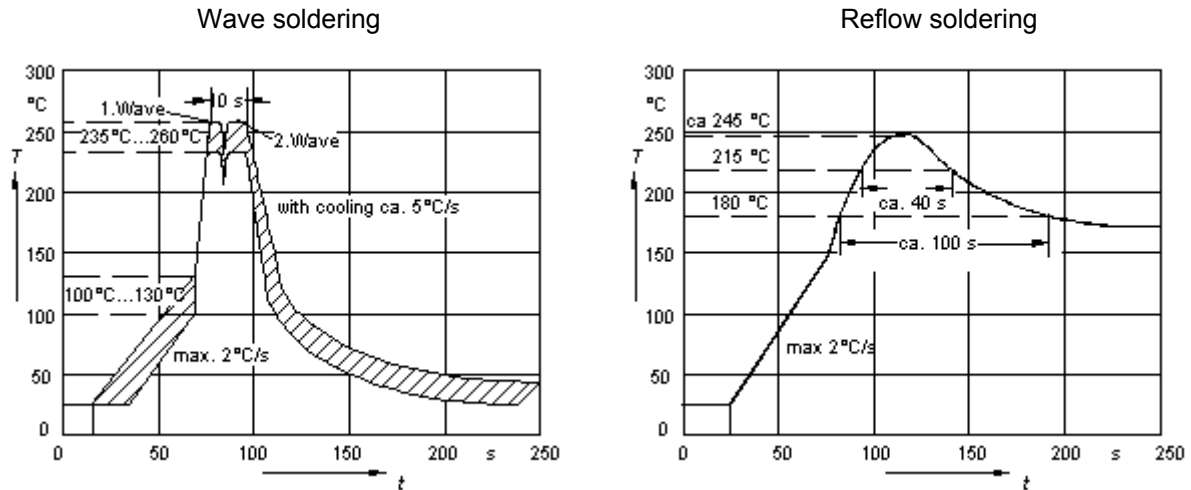

As far as possible, the components shall be employed within 12 months. They should be left in their original packings to avoid soldering problems due to oxidized contacts. Storage temperature: -25 to 45 °C. Relative humidity: <75 % annual average, <95 % on max. 30 days in a year.

The usage of mild, non activated fluxes for soldering is recommended, as well as proper cleaning of the PCB.

Reel dimensions

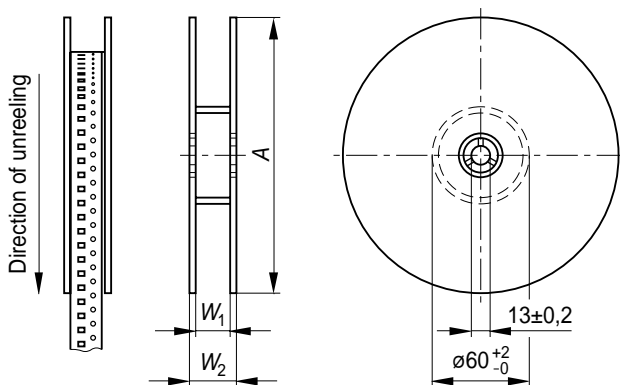

KKE0058-I-E

Definition	Symb.	Dim.	Tol.	Unit
Reel diameter	A	180	+0 /-3	mm
Reel width (inside)	W ₁	8.4	+1.5/-0	mm
Reel width (outside)	W ₂	14.4	max.	mm

Package: 8 mm tape
Reel material: plastic

ISSUE DATE	07.10.2004	ISSUE	g	PUBLISHER	KB VS PE	PAGE	6/8
------------	------------	-------	---	-----------	----------	------	-----

Taping according to IEC 60286-3

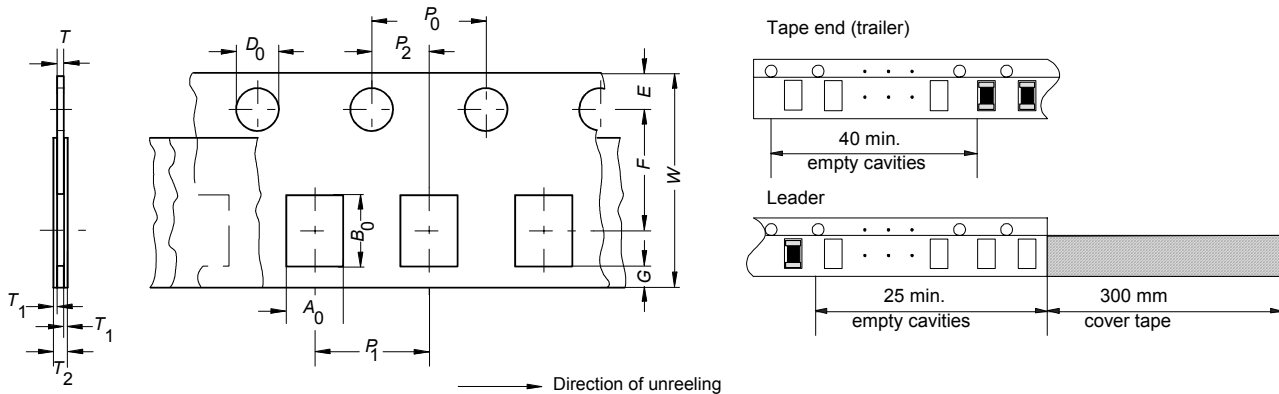









Tape material: cardboard

Dimensions and tolerances

Definition	Symbol	Dim.	Tolerance
Compartment width	A_0	0.95	± 0.2
Compartment length	B_0	1.8	± 0.2
Sprocket hole diameter	D_0	1.5	+0.1/-0
Sprocket hole pitch	P_0	4.0	± 0.1 ¹⁾
Distance center hole to center compartment	P_2	2.0	± 0.05
Pitch of the component compartments	P_1	4.0	± 0.1
Tape width	W	8.0	± 0.3
Distance edge to center of hole	E	1.75	± 0.1
Distance center hole to center compartment	F	3.5	± 0.05
Distance compartment to edge	G	0.75	min.
Thickness of cardboard tape	T	0.9	max.
Overall thickness	T_2	1.1	max.

¹⁾ $\leq \pm 0.2$ mm over any 10 pitches

Data sheet
Type designation

CD	S	3	C	05	G	T	A
							
Cera Diode	Single type	Chip size 3 = 0603	Chip	DC working voltage	Reel size G = 180 mm	Termination T = Nickel barrier	Suffi x

Selection Guide

Part number	Ordering code	Standard DC working voltage (10 µA max.)	Maximum DC working voltage	Qty per reel	Reel size
CDS3C05GTA	B72500D0050A060	3.3 V	5.6 V	4000	180 mm
CDS3C09GTA	B72500D0090A060	5.6 V	9.0 V	4000	180 mm
CDS3C15GTA	B72500D0150A060	9.0 V	16.0 V	4000	180 mm
CDS3C20GTA	B72500D0200A060	12.0 V	22.0 V	4000	180 mm

CeraDiodes are not suitable for switching applications or for voltage stabilization, where static power dissipation is required. CeraDiodes are designed for ESD protection and transient suppression!

© EPCOS AG 2004. Reproduction, publication and dissemination of this data sheet, enclosures hereto and the information contained therein without EPCOS' prior express consent is prohibited.

Purchase orders are subject to the General Conditions for the Supply of Products and Services of the Electrical and Electronics Industry recommended by the ZVEI (German Electrical and Electronic Manufacturers' Association), unless otherwise agreed.

ISSUE DATE	07.10.2004	ISSUE	g	PUBLISHER	KB VS PE	PAGE	8/8
------------	------------	-------	---	-----------	----------	------	-----