

Disposable Blood Pressure Sensor
AAMI Specification
Low Cost
Multiple Configurations

- ▶ Disposable Blood Pressure
- ▶ Measurements
- ▶ Kidney Dialysis Machines
- ▶ Medical Instrumentation

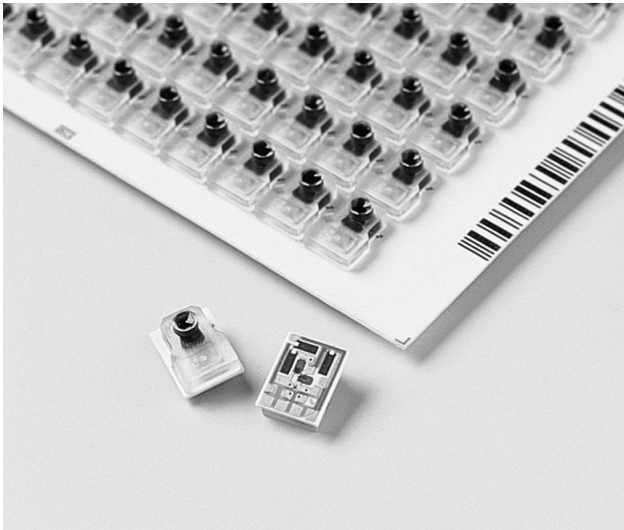

DESCRIPTION

The Model 1620 is a fully piezoresistive silicon pressure sensor for use in invasive blood pressure monitoring. The sensor is designed to be used with automated assembly equipment and can be dropped directly into a customer's disposable blood pressure housing. The sensor is designed to meet the requirements as described in the Association for the Advancement of Medical Instrumentation (AAMI) specification for Blood Pressure Transducers.

The pressure sensor consists of a pressure sensing element mounted on a ceramic substrate. Thick-film resistors on the ceramic substrate are laser-trimmed for compensation and calibration.

A plastic cap is attached to the ceramic substrate to provide an easy method of attachment to the customer's assembly and protection for the sensing element. A dielectric gel is placed over the sensor to provide electrical and fluid isolation.

The Model 1620 pressure sensors are batch manufactured in a 10x12 element array on a ceramic substrate (120 units per substrate). The products are shipped in anti-static shipping containers. Performance characteristics and packaging can be easily tailored on a special order basis to meet the requirements of specific customers.

FEATURES

- ▶ Low Cost Disposable Design
- ▶ Solid State Piezoresistive Sensor
- ▶ Top Side Pressure Entry
- ▶ Compatible with Automated Assembly Equipment
- ▶ Integral Dielectric Gel Barrier
- ▶ Fully Tested and Compensated

STANDARD RANGE

-30 to 300 mmHg

PERFORMANCE SPECIFICATIONS

Supply Voltage: 6.0 VDC

Ambient Temperature: 25°C (Unless otherwise specified)

PARAMETERS	MIN	TYP	MAX	UNITS	NOTES
Operating Pressure Range	-30		300	mmHg	
Overpressure	125			PSI	
Zero Pressure Offset			±20	mmHg	
Sensitivity	4.95	5.0	5.05	μV/V/mmHg	
Calibration	97.5	100	102.5	mmHg	1
Linearity & Hysteresis (-30 to 100 mmHg)			1	mmHg	
Linearity & Hysteresis (>100 to 200 mmHg)			1	% output	
Linearity & Hysteresis (>200 to 300 mmHg)			1.5	% output	
Input Impedance	1200		3200	Ω	2
Output Impedance	285		315	Ω	
Output Symmetry	0.95		1.05	ratio	7
Supply Voltage	1	6	10	VDC	
Risk Current (at 120 VAC rms 60 Hz)			2	mA	
Warm-up Time		5		seconds	
Frequency Response	1200			Hz	
Offset Drift			2	mmHg	3
Thermal Span Shift			±0.1	%/°C	4
Thermal Offset Shift			±0.3	mmHg/°C	4
Phase Shift (at 5 kHz)			5	degrees	
Light Sensitivity (3000 Foot Candle)			1	mmHg	
Defibrillator Withstand (400 Joules)	5			discharges	5
Sterilization (ETO)	3			cycles	6
Operating Temperature	+10°C to +40°C				
Storage Temperature	-25°C to +70°C				
Humidity	10 - 90% (non-condensing)				
Operating Product Life	168 hours				
Shelf Life	2 years				
Dielectric Breakdown	10,000 VDC				
Media Interface	Dielectric Gel				
Volume Displacement	4.5 x 10 ⁻⁴ in ³				
Weight	0.5 grams				

Notes

- Output of sensor with no pressure applied and a 150kΩ resistor shorted across +VIN to +OUT.
- For input impedance of 350Ω ± 5% select pad configuration 1.
- Over an 8 hour time period and after warm-up.
- Over operating temperature range (+10°C to +40°C).
- One discharge per minute.
- Sterilization performed by customer.
- Defined as common mode symmetry between signal output and either excitation terminal.

CONNECTIONS AND DIMENSIONS

All dimensions are in inches [millimeters].

BODY STYLE N

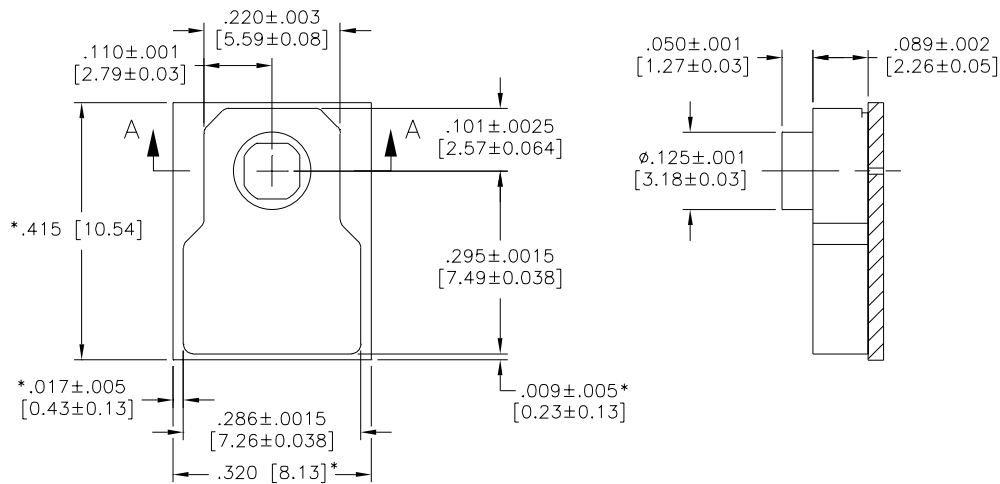

*Dimensions indicated do not include flares.

BODY STYLE W

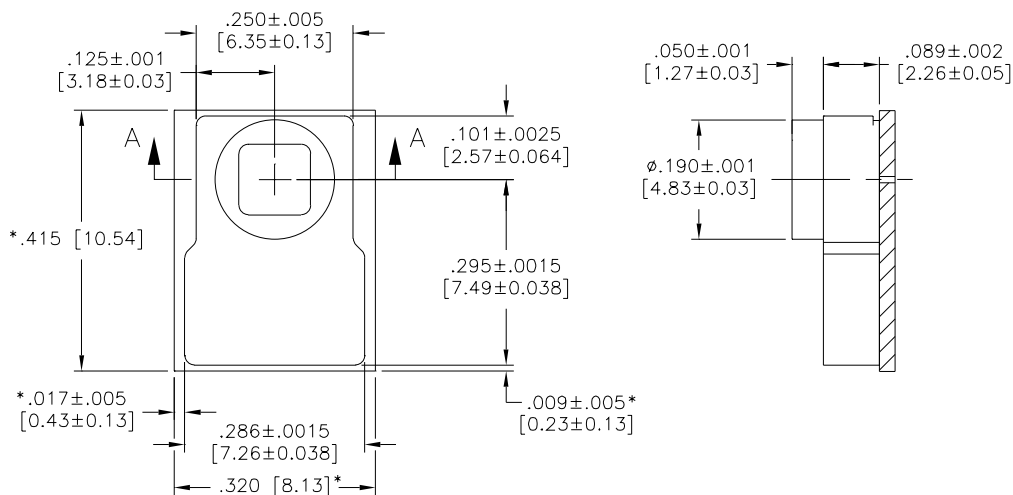

*Dimensions indicated do not include flares.

SECTION A-A

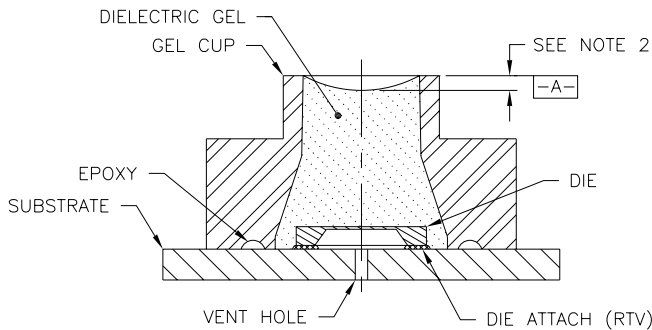

Notes

1. Materials Used:
 Substrate: 96% Alumina
 Transducer (Die): Silicon
 Die Attach Adhesive: Room Temperature Vulcanizer
 Lid Adhesive: Medical Grade UV Curing Adhesive
 Conductor And Contact Pads: Palladium-Silver Alloy
 Wire Bonds And Bond Pads: Gold
 Resistors: Ruthenium-Based Thick Film Paste
 Solder Dams: Green Glass
 Protective Gel Lid: Rad-Stable Poly carbonate Resin
2. Miniscus of Gel:
 Max dimension below surface A = $.035''$ [0.89].
 Max dimension above surface A = $.001''$ [0.03].
3. All dimensions taken at maximum draft.
4. All unspecified fillets and radii are $.015''$ [0.38].
5. All draft angles 1° maximum.

STANDARD PAD CONFIGURATIONS

All dimensions are in inches [millimeters].

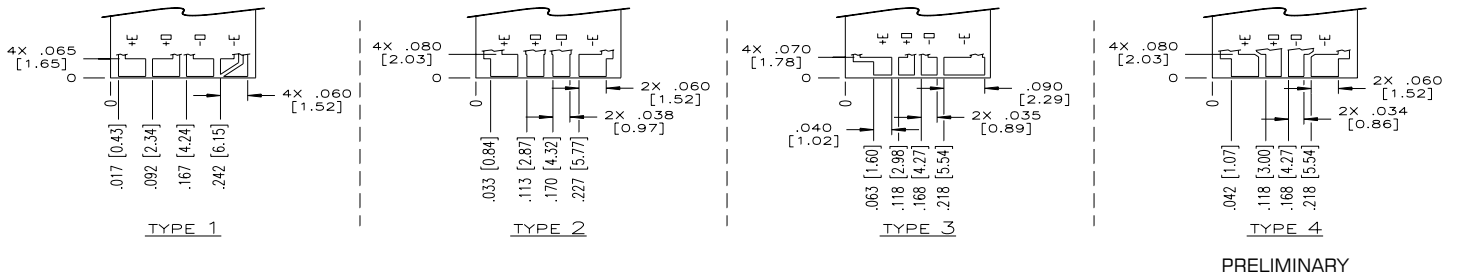

Note

1. Custom pad configurations not shown here may be special ordered. Call IC Sensors for details.

SHIPPING INFORMATION

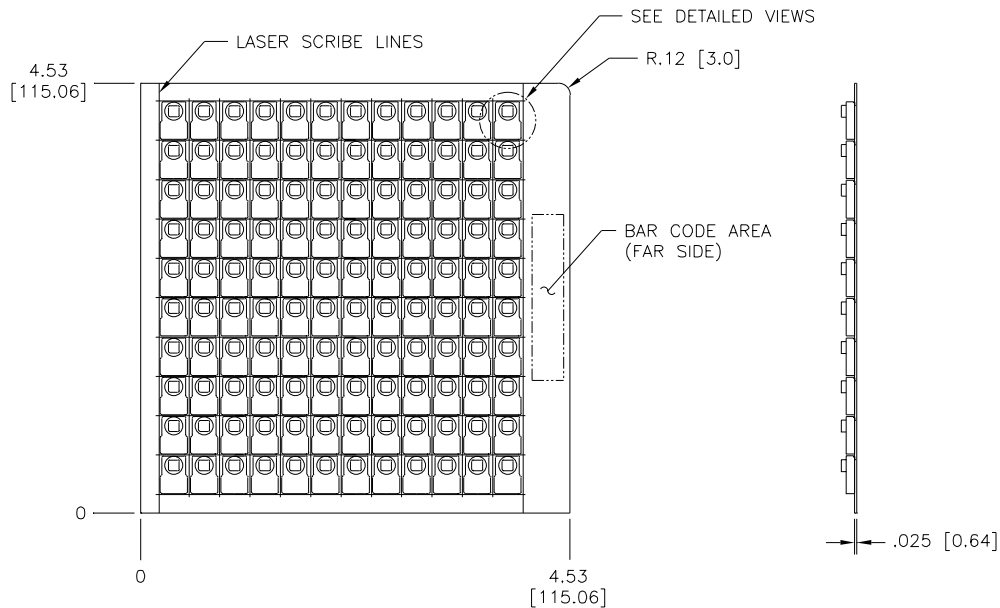

Notes

1. Sensors are shipped as 120 UP snapstrates and must be singulated by the purchaser.
2. Each plate may include units that have failed visual or electrical parameters as well as good units. Bad units are identified with a dot on the backside of the cell location.
3. Plates are shipped in dust free anti-static containers to prevent contamination of the gel surface.

SCHEMATIC DIAGRAM

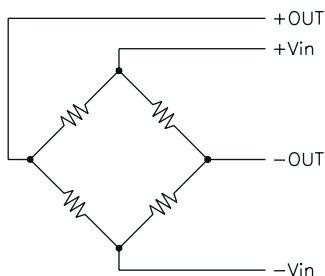

ORDERING INFORMATION

