

## Direct Sequence Spread Spectrum Baseband Processor with Rake Receiver and Equalizer



The Intersil HFA3863 Direct Sequence Spread Spectrum (DSSS) baseband processor is part of the PRISM® 2.4GHz WLAN chip set, and contains

all the functions necessary for a full or half duplex packet baseband transceiver.

The HFA3863 has on-board A/Ds and D/A for analog I and Q inputs and outputs, for which the HFA3783 IF QMODEM is recommended. Differential phase shift keying modulation schemes DBPSK and DQPSK, with data scrambling capability, are available along with complementary code keying to provide a variety of data rates. Built-in flexibility allows the HFA3863 to be configured through a general purpose control bus, for a range of applications. Both receive and transmit AGC functions with 7-bit AGC control obtain maximum performance in the analog portions of the transceiver. The HFA3863 is housed in a thin plastic quad flat package (TQFP) suitable for PCMCIA board applications. It is pin-compatible with the HFA3861B.

### Ordering Information

PART NUMBER	TEMP. RANGE (°C)	PACKAGE	PKG. NO.
HFA3863IN	-40 to 85	64 Ld TQFP	Q64.10x10
HFA3863IN96	-40 to 85	Tape and Reel	

### Pinout

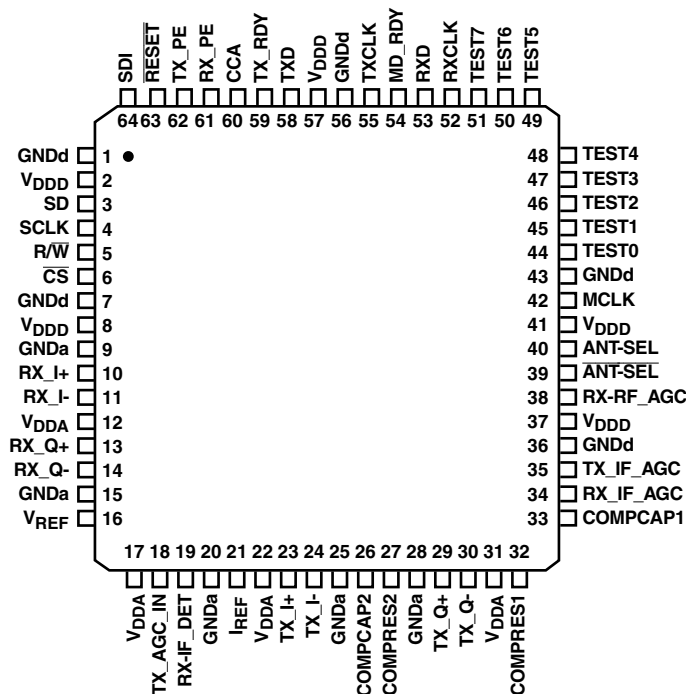

### Features

- Complete DSSS Baseband Processor
- RAKE Receiver with Decision Feedback Equalizer
- Processing Gain . . . . . FCC Compliant
- Programmable Data Rate . . . . . 1, 2, 5.5, and 11Mbps
- Ultra Small Package . . . . . 10 x 10mm
- Single Supply Operation (44MHz Max) . . . . . 2.7V to 3.6V
- Modulation Methods . . . . . DBPSK, DQPSK, and CCK
- Supports Full or Half Duplex Operations
- On-Chip A/D and D/A Converters for I/Q Data (6-Bit, 22MSPS), AGC, and Adaptive Power Control (7-Bit)
- Targeted for Multipath Delay Spreads 125ns at 11Mbps, 250ns at 5.5Mbps
- Supports Short Preamble and Antenna Diversity

### Applications

- Enterprise WLAN Systems
- Systems Targeting IEEE802.11b Standard
- DSSS PCMCIA or Mini-PCI Wireless Transceiver
- Spread Spectrum WLAN RF Modems
- TDMA or CSMA Packet Protocol Radios
- Part 15 Compliant Radio Links
- Portable PDA/Notebook Computer
- Wireless Digital Audio, Video, Multimedia
- PCN / Wireless PBX / Wireless Local Loop
- Wireless Bridges

### Simplified Block Diagram

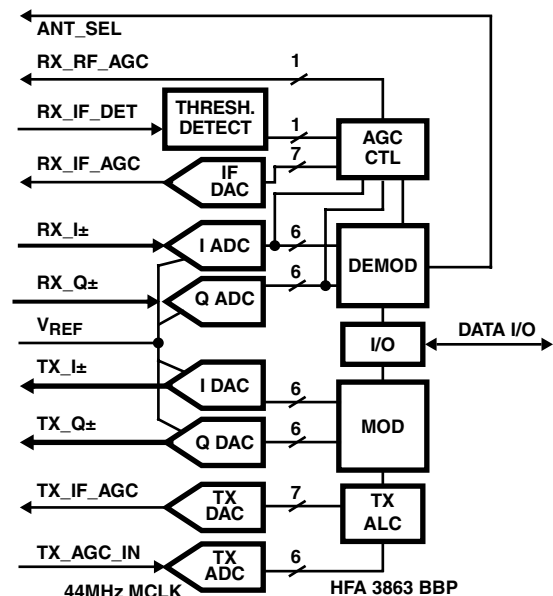

# Typical Application Diagram

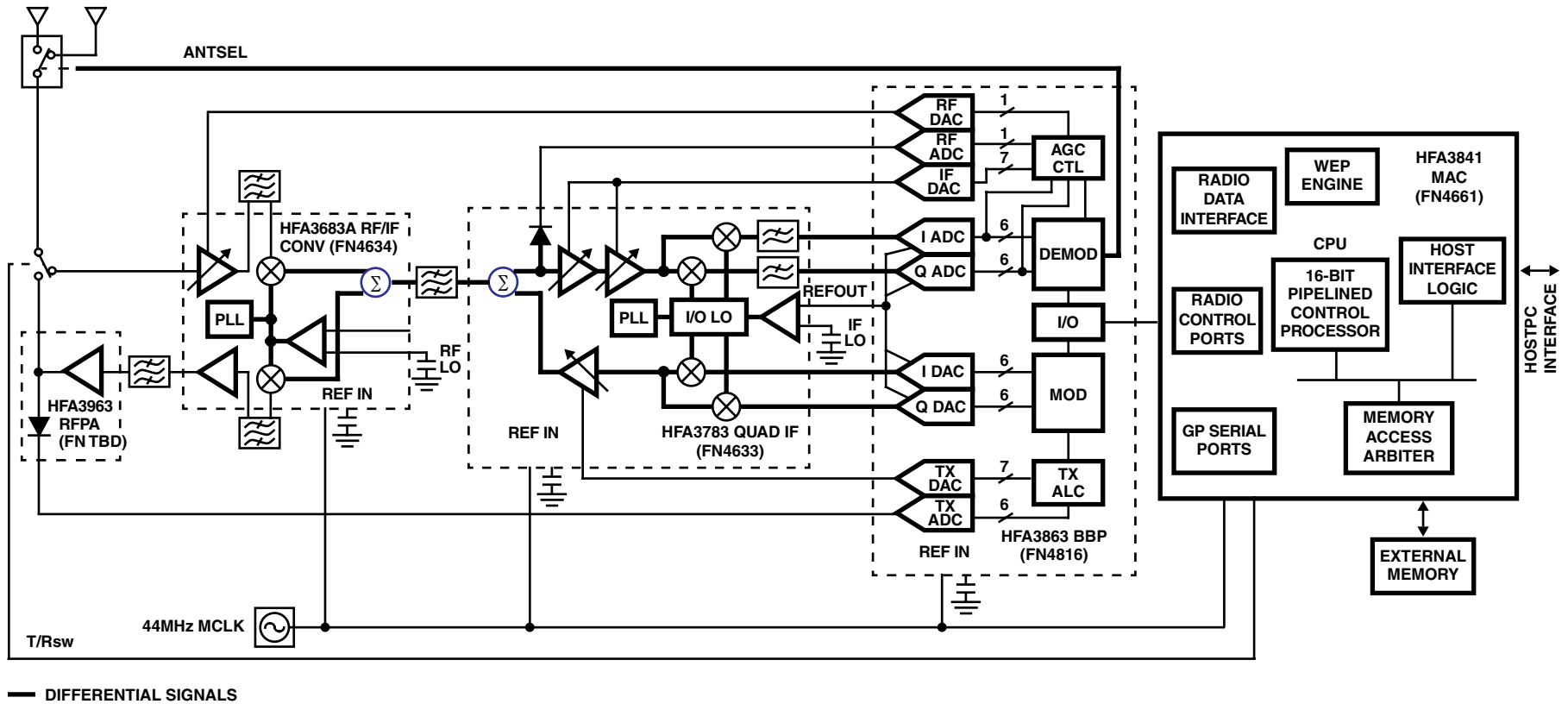

TABLE 1. TYPICAL TRANSCEIVER APPLICATION CIRCUIT USING THE HFA3863

The four-digit file numbers are shown in the Table 1, and correspond to the appropriate circuit.

**Pin Descriptions**

NAME	PIN	TYPE I/O	DESCRIPTION
V <sub>DDA</sub> (Analog)	12, 17, 22, 31	Power	DC power supply 2.7V–3.6V (not hard wired together on chip).
V <sub>DDD</sub> (Digital)	2, 8, 37, 41, 57	Power	DC power supply 2.7–3.6V.
GND <sub>a</sub> (Analog)	9, 15, 20, 25, 28	Ground	DC power supply 2.7–3.6V, ground (not hard wired together on chip).
GND <sub>d</sub> (Digital)	1, 7, 36, 43, 56	Ground	DC power supply 2.7–3.6V, ground.
V <sub>REF</sub>	16	I	Voltage reference for A/D's and D/A's.
I <sub>REF</sub>	21	I	Current reference for internal ADC and DAC devices. Requires a 12kΩ resistor to ground.
RX <sub>I, ±</sub>	10/11	I	Analog input to the internal 6-bit A/D of the In-phase received data. Balanced differential 10+/11-.
RX <sub>Q, ±</sub>	13/14	I	Analog input to the internal 6-bit A/D of the Quadrature received data. Balanced differential 13+/14-.
ANTSEL	39	O	The antenna select signal changes state as the receiver switches from antenna to antenna during the acquisition process in the antenna diversity mode. This is a complement for ANTSEL (pin 40) for differential drive of antenna switches.
ANTSEL	40	O	The antenna select signal changes state as the receiver switches from antenna to antenna during the acquisition process in the antenna diversity mode. This is a complement for ANTSEL (pin 39) for differential drive of antenna switches.
RX_IF_DET	19	I	Analog input to the receive power A/D converter for AGC control.
RX_IF_AGC	34	O	Analog drive to the IF AGC control.
RX_RF_AGC	38	O	Drive to the RF AGC stage attenuator. CMOS digital.
TX_AGC_IN	18	I	Input to the transmit power A/D converter for transmit AGC control.
TX_IF_AGC	35	O	Analog drive to the transmit IF power control.
TX_PE	62	I	When active, the transmitter is configured to be operational, otherwise the transmitter is in standby mode. TX_PE is an input from the external Media Access Controller (MAC) or network processor to the HFA3863. The rising edge of TX_PE will start the internal transmit state machine and the falling edge will initiate shutdown of the state machine. TX_PE envelopes the transmit data except for the last bit. The transmitter will continue to run for 4μs after TX_PE goes inactive to allow the PA to shutdown gracefully.
TXD	58	I	TXD is an input, used to transfer MAC payload data unit (MPDU) data from the MAC or network processor to the HFA3863. The data is received serially with the LSB first. The data is clocked in the HFA3863 at the rising edge of TXCLK.
TXCLK	55	O	TXCLK is a clock output used to receive the data on the TXD from the MAC or network processor to the HFA3863, synchronously. Transmit data on the TXD bus is clocked into the HFA3863 on the rising edge. The clocking edge is also programmable to be on either phase of the clock. The rate of the clock will be dependent upon the data rate that is programmed in the signalling field of the header.
TX_RDY	59	O	TX_RDY is an output to the external network processor indicating that preamble and header information has been generated and that the HFA3863 is ready to receive the data packet from the network processor over the TXD serial bus.
CCA	60	O	Clear channel assessment (CCA) is an output used to signal that the channel is clear to transmit. The CCA may be configured to one of four possible algorithms. The CCA algorithm and its features are described elsewhere in the data sheet. Logic 0 = Channel is clear to transmit. Logic 1 = Channel is NOT clear to transmit (busy). This polarity is programmable and can be inverted.
RXD	53	O	RXD is an output to the external network processor transferring demodulated header information and data in a serial format. The data is sent serially with the LSB first. The data is frame aligned with MD_RDY.
RXCLK	52	O	RXCLK is the bit clock output. This clock is used to transfer header information and payload data through the RXD serial bus to the network processor. This clock reflects the bit rate in use. RXCLK is held to a logic "0" state during the CRC16 reception. RXCLK becomes active after the SFD has been detected. Data should be sampled on the rising edge. This polarity is programmable and can be inverted.

**Pin Descriptions** (Continued)

NAME	PIN	TYPE I/O	DESCRIPTION
MD_RDY	54	O	MD_RDY is an output signal to the network processor, indicating header data and a data packet are ready to be transferred to the processor. MD_RDY is an active high signal that signals the start of data transfer over the RXD serial bus. MD_RDY goes active when the SFD (Note) is detected and returns to its inactive state when RX_PE goes inactive or an error is detected in the header.
RX_PE	61	I	When active, the receiver is configured to be operational, otherwise the receiver is in standby mode. This is an active high input signal. In standby, RX_PE inactive, all RX A/D converters are disabled.
SD	3	I/O	SD is a serial bidirectional data bus which is used to transfer address and data to/from the internal registers. The bit ordering of an 8-bit word is MSB first. The first eight bits during transfers indicate the register address immediately followed by 8 more bits representing the data that needs to be written or read at that register. In the 4-wire interface mode, this pin is three-stated unless the R/W pin is high.
SCLK	4	I	SCLK is the clock for the SD serial bus. The data on SD is clocked at the rising edge. SCLK is an input clock and it is asynchronous to the internal master clock (MCLK). The maximum rate of this clock is 11MHz or one half the master clock frequency, whichever is lower.
SDI	64	I	Serial Data Input in 3-wire mode described in Tech Brief 383. This pin is not used in the 4-wire interface described in this data sheet. It should not be left floating.
R/W	5	I	R/W is an input to the HFA3863 used to change the direction of the SD bus when reading or writing data on the SD bus. R/W must be set up prior to the rising edge of SCLK. A high level indicates read while a low level is a write.
$\overline{CS}$	6	I	$\overline{CS}$ is a Chip select for the device to activate the serial control port. The $\overline{CS}$ doesn't impact any of the other interface ports and signals, i.e., the TX or RX ports and interface signals. This is an active low signal. When inactive SD, SCLK, and R/W become "don't care" signals.
TEST 7:0	51, 50, 49, 48, 47, 46, 45, 44	I/O	This is a data port that can be programmed to bring out internal signals or data for monitoring. These bits are primarily reserved by the manufacturer for testing. A further description of the test port is given in the appropriate section of this data sheet.
$\overline{RESET}$	63	I	Master reset for device. When active TX and RX functions are disabled. If $\overline{RESET}$ is kept low the HFA3863 goes into the power standby mode. $\overline{RESET}$ does not alter any of the configuration register values nor does it preset any of the registers into default values. Device requires programming upon power-up. See the section on Control Register 2 bit 0 for important initialization information.
MCLK	42	I	Master Clock for device. The nominal frequency of this clock is 44MHz. This is used internally to generate all other internal necessary clocks and is divided by 2 or 4 for the transceiver clocks.
TXI $\pm$	23/24	O	TX Spread baseband I digital output data. Data is output at the chip rate. Balanced differential 23+/24-.
TXQ $\pm$	29/30	O	TX Spread baseband Q digital output data. Data is output at the chip rate. Balanced differential 29+/30-.
CompCap	33	I	Compensation Capacitor.
CompCap2	26	I	Compensation Capacitor.
CompRes1	32	I	Compensation Resistor.
CompRes2	27	I	Compensation Resistor.

NOTE: See CR10[3].

**External Interfaces**

There are three primary digital interface ports for the HFA3863 that are used for configuration and during normal operation of the device as shown in Figure 1. These ports are:

- The **Control port**, which is used to configure, write and/or read the status of the internal HFA3863 registers.
- The **TX port**, which is used to accept the data that needs to be transmitted from the network processor.
- The **RX port**, which is used to output the received demodulated data to the network processor.

In addition to these primary digital interfaces the device includes a byte wide parallel Test port which can be configured to output various internal signals and/or data. The device can also be set into various power consumption modes by external control. The HFA3863 contains three analog to digital (A/D) converters and four digital to analog converters. The analog interfaces to the HFA3863 include, the In phase (I) and quadrature (Q) data component inputs/ outputs, and the RF and IF receive automatic gain control and transmit output power control.

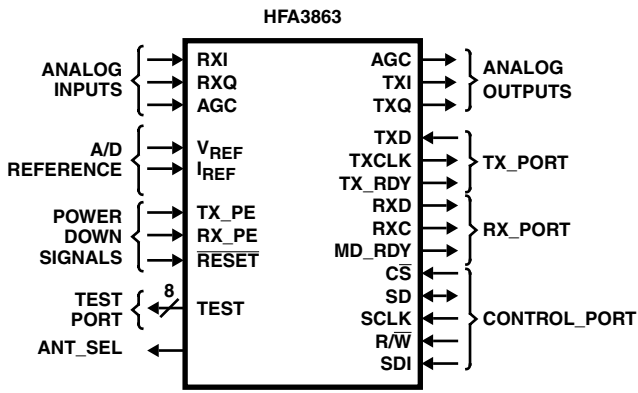

FIGURE 1. EXTERNAL INTERFACES

### Control Port (4 Wire)

The serial control port is used to serially write and read data to/from the device. This serial port can operate up to a 11MHz rate or 1/2 the maximum master clock rate of the device, MCLK (whichever is lower). MCLK must be running and RESET must be inactive during programming. This port is used to program and to read all internal registers. The first eight bits always represent the address followed immediately by the eight data bits for that register. The LSB of the address is a don't care, but reserved for future

expansion. The serial transfers are accomplished through the serial data pin (SD). SD is a bidirectional serial data bus. Chip Select ( $\overline{CS}$ ), and Read/Write ( $R/\overline{W}$ ) are also required as handshake signals for this port. The clock used in conjunction with the address and data on SD is SCLK. This clock is provided by the external source and it is an input to the HFA3863. The timing relationships of these signals are illustrated in Figures 2 and 3.  $R/\overline{W}$  is high when data is to be read, and low when it is to be written.  $\overline{CS}$  is an asynchronous reset to the state machine.  $\overline{CS}$  must be active (low) during the entire data transfer cycle.  $\overline{CS}$  selects the serial control port device only. The serial control port operates asynchronously from the TX and RX ports and it can accomplish data transfers independent of the activity at the other digital or analog ports.

The HFA3863 has 96 internal registers that can be configured through the control port. These registers are listed in the Configuration and Control Internal Register table. Table 10 lists the configuration register number, a brief name describing the register, the HEX address to access each of the registers and typical values. The type indicates whether the corresponding register is Read only (R) or Read/Write (R/W). Some registers are two bytes wide as indicated on the table (high and low bytes).

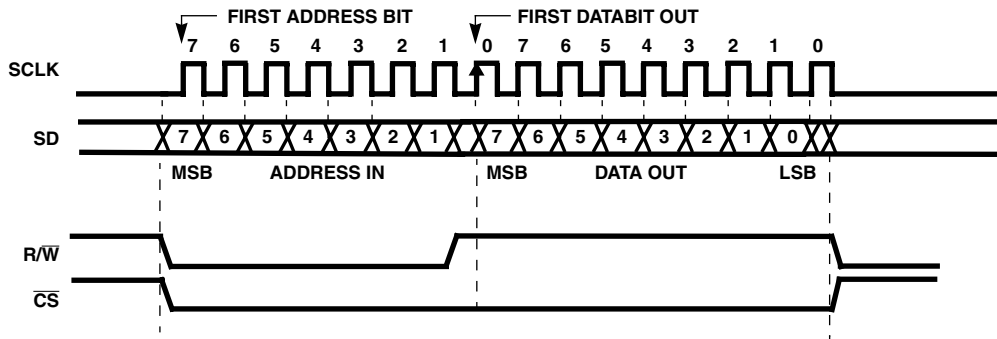

NOTES:

1. The HFA3863 always uses the rising edge of SCLK to sample address and data and to generate read data.
2. These figures show the controller using the falling edge of SCLK to generate address and data and to sample read data.

FIGURE 2. CONTROL PORT READ TIMING

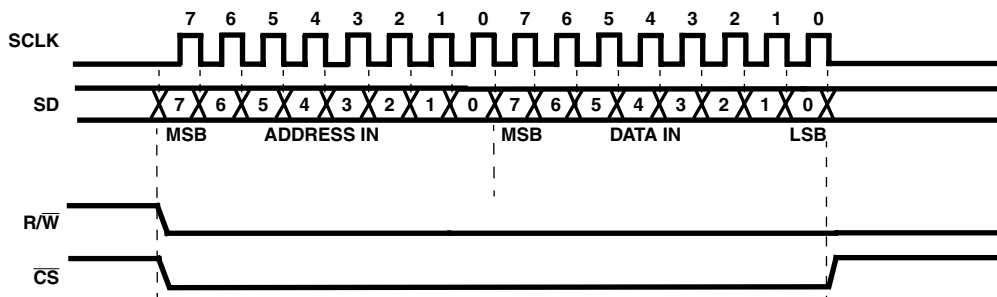

FIGURE 3. CONTROL PORT WRITE TIMING

### TX Port

The transmit data port accepts the data that needs to be transmitted serially from an external data source. The data is modulated and transmitted as soon as it is received from the external data source. The serial data is input to the HFA3863 through TXD using the next rising edge of TXCLK to clock it in the HFA3863. TXCLK is an output from the HFA3863. A timing scenario of the transmit signal handshakes and sequence is shown on timing diagram Figure 4.

The external processor initiates the transmit sequence by asserting TX\_PE. TX\_PE envelopes the transmit data packet on TXD. The HFA3863 responds by generating a Preamble and Header. Before the last bit of the Header is sent, the HFA3863 begins generating TXCLK to input the serial data on TXD. TXCLK will run until TX\_PE goes back to its inactive state indicating the end of the data packet. The user needs to hold TX\_PE high for as many clocks as there bits to transmit. For the higher data rates, this will be in multiples of the number of bits per symbol. The HFA3863 will continue to output modulated signal for 4μs after the last data bit is output, to supply bits to flush the modulation path. TX\_PE must be held until the last data bit is output from the MAC/FIFO. The minimum TX\_PE inactive pulse required to restart the preamble and header generation is 2.22μs and to reset the modulator is 4.22μs.

The HFA3863 internally generates the preamble and header information from information supplied via the control registers. The external source needs to provide only the data portion of the packet and set the control registers. The timing diagram of this process is illustrated on Figure 4. Assertion of TX\_PE will initialize the generation of the preamble and header. TX\_RDY, which is an output from the HFA3863, is used (if needed) to indicate to the external processor that the preamble has been generated and the device is ready to receive the data packet (MPDU) to be transmitted from the external processor. Signals TX\_RDY, TX\_PE and TXCLK can be set individually, by programming Configuration Register (CR) 1, as either active high or active low signals.

The transmit port is completely independent from the operation of the other interface ports including the RX port, therefore supporting a full duplex mode.

### RX Port

The timing diagram Figure 5 illustrates the relationships between the various signals of the RX port. The receive data port serially outputs the demodulated data from RXD. The data is output as soon as it is demodulated by the HFA3863. RX\_PE must be at its active state throughout the receive operation. When RX\_PE is inactive the device's receive functions, including acquisition, will be in a stand by mode.

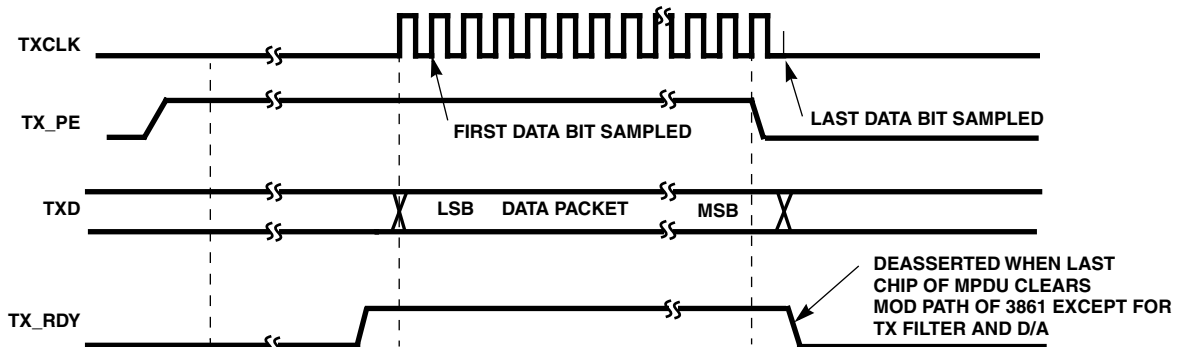

NOTE: Preamble/Header and Data is transmitted LSB first. TXD shown generated from rising edge of TXCLK.

FIGURE 4. TX PORT TIMING

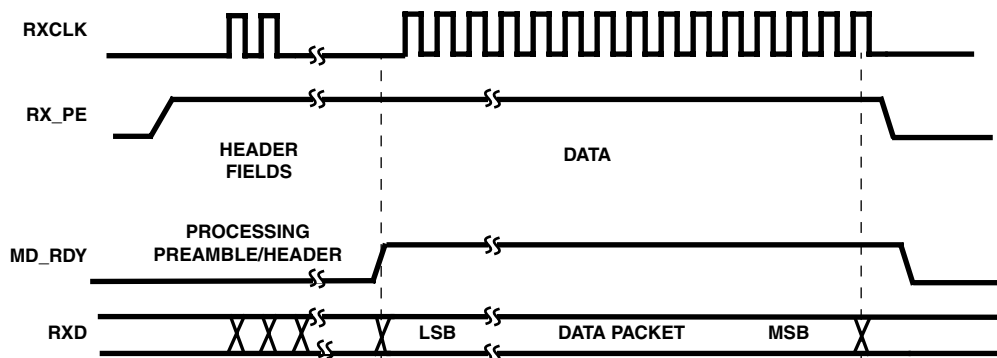

NOTE: MD\_RDY active after CRC16. See detailed timing diagrams (Figures 21, 22, 23).

FIGURE 5. RX PORT TIMING



RXCLK is an output from the HFA3863 and is the clock for the serial demodulated data on RXD. MD\_RDY is an output from the HFA3863 and it may be set to go active after the SFD or CRC fields. Note that RXCLK becomes active after the start frame delimiter (SFD) to clock out the Signal, Service, and Length fields, then goes inactive during the header CRC field. RXCLK becomes active again for the data. MD\_RDY returns to its inactive state after RX\_PE is deactivated by the external controller, or if a header error is detected. A header error is either a failure of the CRC check, or the failure of the received signal field to match one of the four programmed signal fields. For either type of header error, the HFA3863 will reset itself after reception of the CRC field. If MD\_RDY had been set to go active after CRC, it will remain low.

MD\_RDY and RXCLK can be configured through CR 1, bits 1 and 0 to be active low, or active high. The receive port is completely independent from the operation of the other interface ports including the TX port, supporting therefore a full duplex mode.

### RX I/Q A/D Interface

The PRISM baseband processor chip (HFA3863) includes two 6-bit analog to digital converters (A/Ds) that sample the balanced differential analog input from the IF down converter device (HFA3783). The I/Q A/D clock, samples at twice the chip rate with a nominal sampling rate of 22MHz.

The interface specifications for the I and Q A/Ds are listed in Table 2. The HFA3863 is designed to be DC coupled to the HFA3783.

TABLE 2. I, Q, A/D SPECIFICATIONS

PARAMETER	MIN	TYP	MAX
Full Scale Input Voltage ( $V_{P-P}$ )	0.90	1.00	1.10
Input Bandwidth (-0.5dB)	-	11MHz	-
Input Capacitance (pF)	-	2	-
Input Impedance (DC)	5k $\Omega$	-	-
$f_S$ (Sampling Frequency)	-	22MHz	-

The voltages applied to pin 16,  $V_{REF}$  and pin 21,  $I_{REF}$  set the references for the internal I and Q A/D converters. In addition, For a nominal I/Q input of 400mV $_{P-P}$ , the suggested  $V_{REF}$  voltage is 1.2V.

### AGC Circuit

The AGC circuit is designed to adjust for signal level variations and optimize A/D performance for the I and Q inputs by maintaining the proper headroom on the 6-bit converters. There are two gain stages being controlled. At RF, the gain control is a 30dB step change. This RF gain control optimizes the receiver dynamic range when the signal level is high and maintains the noise figure of the receiver when it is needed most at low signal level. At IF the gain control is linear and covers the bulk of the gain control range of the receiver.

The AGC loop is partially digital which allows for holding the gain fixed during a packet. The AGC sensing mechanism uses a combination of the I and Q A/D converters and the detected signal level in the IF to determine the gain settings. The A/D outputs are monitored in the HFA3863 for the desired nominal level. When it is reached, by adjusting the receiver gain, the gain control is locked for the remainder of the packet.

### RX\_AGC\_IN Interface

The signal level in the IF stage is monitored to determine when to impose the 30dB gain reduction in the RF stage. This maximizes the dynamic range of the receiver by keeping the RF stages out of saturation at high signal levels. When the IF circuit's sensor output reaches 0.5V $_{DD}$ , the HFA3863 comparator switches in the 30dB pad and also adds 30dB of gain to the IF AGC amplifier. This compensates the IF AGC and RSSI measures.

### TX I/Q DAC Interface

The transmit section outputs balanced differential analog signals from the transmit DACs to the HFA3783. These are DC coupled and digitally filtered.

### Test Port

The HFA3863 provides the capability to access a number of internal signals and/or data through the Test port, pins TEST 7:0. The test port is programmable through configuration register (CR 34). Any signal on the test port can also be read from configuration register (CR50) via the serial control port. Additionally, the transmit DACs can be configured to show signals in the receiver via CR 14. This allows visibility to analog like signals that would normally be very difficult to capture.

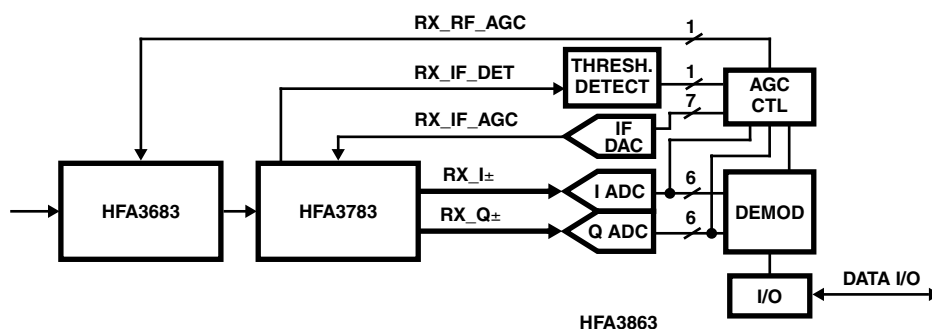

FIGURE 6. AGC CIRCUIT

### Power Down Modes

The power consumption modes of the HFA3863 are controlled by the following control signals.

Receiver Power Enable (RX\_PE, pin 61), which disables the receiver when inactive.

Transmitter Power Enable (TX\_PE, pin 62), which disables the transmitter when inactive.

Reset ( $\overline{\text{RESET}}$ , pin 63), which puts the receiver in a sleep mode. The power down mode where, both  $\overline{\text{RESET}}$  and RX\_PE are used is the lowest possible power consumption mode for the receiver. Exiting this mode requires a maximum of 10 $\mu$ s before the device is operational.

The contents of the configuration registers are not effected by any of the power down modes. No reconfiguration is required when returning to operational modes. Activation of RESET does *not* corrupt learned values of AGC settings and noise floor values.

Table 3 describes the power down modes available for the HFA3863 ( $V_{CC} = 3.3V$ ). The table values assume that all other inputs to the part (MCLK, SCLK, etc.) continue to run except as noted.

### Transmitter Description

The HFA3863 transmitter is designed as a direct sequence spread spectrum phase shift keying (DSSS PSK) modulator. It can handle data rates of up to 11Mbps (refer to AC and DC specifications). The various modes of the modulator are differential binary phase shift keying (DBPSK) for 1Mbps, differential quaternary phase shift keying (DQPSK) for 2Mbps, and complementary code keying (CCK) for 5.5Mbps and 11Mbps. These implement data rates as shown in Table 4. The major functional blocks of the transmitter include a network processor interface, DPSK modulator, high rate modulator, a data scrambler and a spreader, as shown in Figure 7. CCK is essentially a quadra-phase form of M-ARY Orthogonal Keying. A description of that modulation can be found in Chapter 5 of: *Telecommunications System Engineering*, by Lindsey and Simon, Prentis Hall publishing.

The preamble is always transmitted as the DBPSK waveform while the header can be configured to be either DBPSK, or DQPSK, and data packets can be configured for DBPSK, DQPSK, or CCK. The preamble is used by the receiver to achieve initial PN synchronization while the header includes the necessary data fields of the communications protocol to establish the physical layer link. The transmitter generates the synchronization preamble and header and knows when to make the DBPSK to DQPSK or CCK switchover, as required.

TABLE 3. POWER DOWN MODES

MODE	RX_PE	TX_PE	RESET	AT 44MHz	DEVICE STATE
SLEEP	Inactive	Inactive	Active	1mA	Both transmit and receive functions disabled. Device in sleep mode. Control Interface is still active. Register values are maintained. Device will return to its active state within 10 $\mu$ s.
STANDBY	Inactive	Inactive	Inactive	1.5mA	Both transmit and receive operations disabled. Device will resume its operational state within 1 $\mu$ s of RX_PE or TX_PE going active.
TX	Inactive	Active	Inactive	15mA	Receiver operations disabled. Receiver will return in its operational state within 1 $\mu$ s of RX_PE going active.
RX	Active	Inactive	Inactive	50mA	Transmitter operations disabled. Transmitter will return to its operational state within 2 MCLKs of TX_PE going active.
NO CLOCK	$I_{CC}$ Standby		Active	300 $\mu$ A	All inputs at $V_{CC}$ or GND.



TABLE 4. BIT RATE TABLE EXAMPLES FOR MCLK = 44MHz

DATA MODULATION	A/D SAMPLE CLOCK (MHz)	TX SETUP CR 5 BITS 1, 0	RX SIGNAL CR 63 BITS 7, 6	DATA RATE (Mbps)	SYMBOL RATE (MSPS)
DBPSK	22	00	00	1	1
DQPSK	22	01	01	2	1
CCK	22	10	10	5.5	1.375
CCK	22	11	11	11	1.375

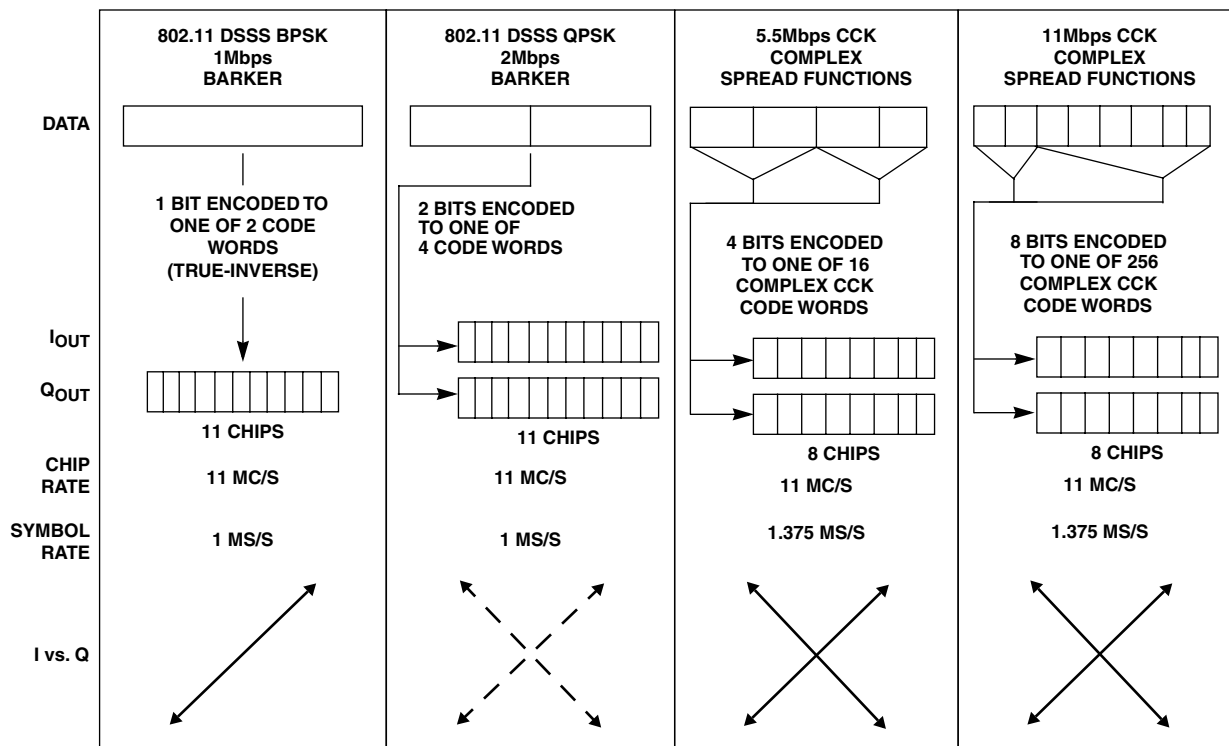

FIGURE 7. MODULATION MODES

For the 1 and 2Mbps modes, the transmitter accepts data from the external source, scrambles it, differentially encodes it as either DBPSK or DQPSK, and spreads it with the BPSK PN sequence. The baseband digital signals are then output to the external IF modulator.

For the CCK modes, the transmitter inputs the data and partitions it into nibbles (four bits) or bytes (eight bits). At 5.5Mbps, it uses two of those bits to select one of four complex spread sequences from a table of CCK sequences and then QPSK modulates that symbol with the remaining two bits. Thus, there are four possible spread sequences to send at four possible carrier phases, but only one is sent. This sequence is then modulated on the I and Q outputs. The initial phase reference for the data portion of the packet is the phase of the last bit of the header. At 11Mbps, one byte is used as above where six bits are used to select one of 64 spread sequences for a symbol and the other two are used to QPSK modulate that symbol. Thus, the total possible

number of combinations of sequence and carrier phases is 256. Of these only one is sent.

The bit rate Table 4 shows examples of the bit rates and the symbol rates and Figure 7 shows the modulation schemes. The modulator is completely independent from the demodulator, allowing the PRISM baseband processor to be used in full duplex operation.

### Header/Package Description

The HFA3863 is designed to handle packetized Direct Sequence Spread Spectrum (DSSS) data transmissions. The HFA3863 generates its own preamble and header information. It uses two packet preamble and header configurations. The first is backwards compatible with the existing IEEE802.11-1997 standard 1 and 2Mbps modes and the second is the optional shortened mode which maximizes throughput at the expense of compatibility with legacy equipment.

In the long preamble mode, the device uses a synchronization preamble of 128 symbols along with a header that includes four fields. The preamble is all 1's (before entering the scrambler) plus a start frame delimiter (SFD). The actual transmitted pattern of the preamble is randomized by the scrambler. The preamble is always transmitted as a DBPSK waveform (1Mbps). The duration of the long preamble and header is 192µs.

In the short preamble mode, the modem uses a synchronization field of 56 zero symbols along with an SFD transmitted at 1Mbps. The short header is transmitted at 2Mbps. The synchronization preamble is all 0s to distinguish it from the long header mode and the short preamble SFD is the time reverse of the long preamble SFD. The duration of the short preamble and header is 96µs.

**Start Frame Delimiter (SFD) Field (16 Bits)** - This field is used to establish the link frame timing. The HFA3863 will not declare a valid data packet, even if it PN acquires, unless it detects the SFD. The HFA3863 receiver auto-detects if the packet is long or short preamble and sets SFD time-out. The timer starts counting after initialization of the de-scrambler is complete.

*The four fields for the header shown in Figure 8 are:*

**Signal Field (8 Bits)** - This field indicates what data rate the data packet that follows the header will be. The HFA3863 receiver looks at the signal field to determine whether it needs to switch from DBPSK demodulation into DQPSK, or CCK demodulation at the end of the preamble and header fields.

**Service Field (8 Bits)** - The MSB of this field is used to indicate the correct length when the length field value is ambiguous at 11Mbps. See IEEE802.11 for definition of the other bits. Bit 2 is used by the HFA3863 to indicate that the carrier reference and the bit timing references are derived from the same oscillator (locked oscillators).

**Length Field (16 Bits)** - This field indicates the number of microseconds it will take to transmit the payload data (PSDU). The external controller (MAC) will check the length field in determining when it needs to de-assert RX\_PE.

**CCITT - CRC 16 Field (16 Bits)** - This field includes the 16-bit CCITT - CRC 16 calculation of the three header fields. This value is compared with the CCITT - CRC 16 code calculated at the receiver. The HFA3863 receiver will indicate a CCITT - CRC 16 error via CR24 bit 2 and will lower MD\_RDY and reset the receiver to the acquisition mode if there is an error.

The CRC or cyclic redundancy check is a CCITT CRC-16 FCS (frame check sequence). It is the ones complement of the remainder generated by the modulo 2 division of the protected bits by the polynomial:

$$x^{16} + x^{12} + x^5 + 1$$

The protected bits are processed in transmit order. All CRC calculations are made ahead of data scrambling. A shift

register with two taps is used for the calculation. It is preset to all ones and then the protected fields are shifted through the register. The output is then complemented and the residual shifted out MSB first.

The following configuration registers (CR) are used to program the preamble/header functions, more programming details about these registers can be found in the Control Registers section of this document:

**CR 3** - Defines the short preamble length minus the SFD in symbols. The IEEE802.11 protocol requires a setting of 56d = 38h for the optional short preamble.

**CR 4** - Defines the long preamble length minus the SFD in symbols. The IEEE802.11 protocol requires a setting of 128d = 80h for the mandatory long preamble.

**CR 5 Bits 0, 1** - These bits of the register set the Signal field to indicate what modulation is to be used for the data portion of the packet.

**CR 6** - The value to be used in the Service field.

**CR 7 and 8** - Defines the value of the transmit data length field. This value includes all symbols following the last header field symbol and is in microseconds required to transmit the data at the chosen data rate.

The packet consists of the preamble, header and MAC protocol data unit (MPDU). The data is transmitted exactly as received from the control processor. Some dummy bits will be appended to the end of the packet to ensure an orderly shutdown of the transmitter. This prevents spectrum splatter. At the end of a packet, the external controller is expected to de-assert the TX\_PE line to shut the transmitter down.

### **Scrambler and Data Encoder Description**

The modulator has a data scrambler that implements the scrambling algorithm specified in the IEEE802.11 standard. This scrambler is used for the preamble, header, and data in all modes. The data scrambler is a self synchronizing circuit. It consists of a 7-bit shift register with feedback from specified taps of the register. Both transmitter and receiver use the same scrambling algorithm. The scrambler can be disabled by setting CR32 bit 2 to 1.

NOTE: Be advised that the IEEE802.11 compliant scrambler in the HFA3863 has the property that it can lock up (stop scrambling) on random data followed by repetitive bit patterns. The probability of this happening is 1/128. The patterns that have been identified are all zeros, all ones, repeated 10s, repeated 1100s, and repeated 111000s. Any break in the repetitive pattern will restart the scrambler. To ensure that this does not cause any problem, the CCK waveform uses a ping pong differential coding scheme that breaks up repetitive 0s patterns.



FIGURE 8. IEEE802.11 PREAMBLE/HEADER

Scrambling is done by division with a prescribed polynomial as shown in Figure 9. A shift register holds the last quotient and the output is the exclusive or of the data and the sum of two taps in the shift register. The transmit scrambler seed for the long preamble or for the short preamble can be set with CR48 or CR49.

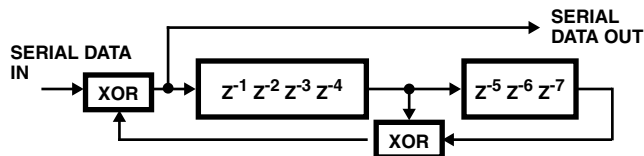

FIGURE 9. SCRAMBLING PROCESS

For the 1Mbps DBPSK data rates and for the header in all rates using the long preamble, the data coder implements the desired DBPSK coding by differential encoding the serial data from the scrambler and driving both the I and Q output channels together. For the 2Mbps DQPSK data rate and for the header in the short preamble mode, the data coder implements the desired coding as shown in the DQPSK Data Encoder table. This coding scheme results from differential coding of dibits (two bits). Vector rotation is counterclockwise although bits 6 and 7 of configuration register CR 1 can be used to reverse the rotation sense of the TX or RX signal if desired.

TABLE 5. DQPSK DATA ENCODER

PHASE SHIFT	DIBIT PATTERN (d0, d1) d0 IS FIRST IN TIME
0	00
+90	01
+180	11
-90	10

### Spread Spectrum Modulator Description

The modulator is designed to generate DBPSK, DQPSK, and CCK spread spectrum signals. The modulator is capable of automatically switching its rate where the preamble is DBPSK modulated, and the data and/or header are modulated differently. The modulator can support data rates of 1, 2, 5.5 and 11Mbps. The programming details to set up the modulator are given at the introductory paragraph of this section. The HFA3863 utilizes quadrature (I/Q) modulation at baseband for all modulation modes.

In the 1Mbps DBPSK mode, the I and Q Channels are connected together and driven with the output of the

scrambler and differential encoder. The I and Q Channels are then both multiplied with the 11-bit Barker word at the spread rate. The I and Q signals go to the Quadrature upconverter (HFA3724) to be modulated onto a carrier. Thus, the spreading and data modulation are BPSK modulated onto the carrier.

For the 2Mbps DQPSK mode, the serial data is formed into dibits or bit pairs in the differential encoder as detailed above. One of the bits from the differential encoder goes to the I Channel and the other to the Q Channel. The I and Q Channels are then both multiplied with the 11-bit Barker word at the spread rate. This forms QPSK modulation at the symbol rate with BPSK modulation at the spread rate.

### Transmit Filter Description

To minimize the requirements on the analog transmit filtering, the transmit section shown in Figure 11 has an output digital filter. This filter is a finite impulse response (FIR) style filter whose passband shape is set by tap coefficients. This filter shapes the spectrum to meet the radio spectral mask requirements while minimizing the peak to average amplitude on the output. To meet the particular spread spectrum processing gain regulatory requirements in Japan on channel 14, an extra FIR filter shape has been included that has a wider main lobe. This increases the 90% power bandwidth from about 11MHz to 14MHz. It has the unavoidable side effect of increasing the amplitude modulation, so the available transmit power is compromised by 2dB when using this filter (CR 11 bit 5).

### CCK Modulation

For the CCK modes, the spreading code length is eight complex chips and based on complementary codes. The chipping rate is 11Mchip/s. The following formula is used to derive the CCK code words that are used for spreading both 5.5 and 11Mbps:

$$c = \left\{ \begin{matrix} e^{j(\varphi_1 + \varphi_2 + \varphi_3 + \varphi_4)}, e^{j(\varphi_1 + \varphi_3 + \varphi_4)}, e^{j(\varphi_1 + \varphi_2 + \varphi_4)}, \\ -e^{j(\varphi_1 + \varphi_4)}, e^{j(\varphi_1 + \varphi_2 + \varphi_3)}, e^{j(\varphi_1 + \varphi_3)}, -e^{j(\varphi_1 + \varphi_2)}, e^{j\varphi_1} \end{matrix} \right\}$$

(LSB to MSB), where c is the code word.

The terms:  $\varphi_1$ ,  $\varphi_2$ ,  $\varphi_3$ , and  $\varphi_4$  are defined below for 5.5Mbps and 11Mbps.

This formula creates eight complex chips (LSB to MSB) that are transmitted LSB first. The coding is a form of the generalized Hadamard transform encoding where the phase

$\varphi_1$  is added to all code chips,  $\varphi_2$  is added to all odd code chips,  $\varphi_3$  is added to all odd pairs of code chips and  $\varphi_4$  is added to all odd quads of code chips.

The phase  $\varphi_1$  modifies the phase of all code chips of the sequence and is DQPSK encoded for 5.5 and 11Mbps. This will take the form of rotating the whole symbol by the appropriate amount relative to the phase of the preceding symbol. Note that the last chip of the symbol defined above is the chip that indicates the symbol's reference phase.

For the 5.5Mbps CCK mode, the output of the scrambler is partitioned into nibbles. The first two bits are encoded as differential symbol phase modulation in accordance with Table 6. All odd numbered symbols of the MPDU are given an extra 180 degree ( $\pi$ ) rotation in addition to the standard DQPSK modulation as shown in the table. The symbols of the MPDU shall be numbered starting with "0" for the first symbol for the purposes of determining odd and even symbols. That is, the MPDU starts on an even numbered symbol. The last data dibits d2, and d3 CCK encode the basic symbol as specified in Table 7. This table is derived from the CCK formula above by setting  $\varphi_2 = (d2 \cdot \pi) + \pi/2$ ,  $\varphi_3 = 0$ , and  $\varphi_4 = d3 \cdot \pi$ . In the table d2 and d3 are in the order shown and the complex chips are shown LSB to MSB (left to right) with LSB transmitted first.

TABLE 6. DQPSK ENCODING TABLE

DIBIT PATTERN (d(0), d(1)) d(0) IS FIRST IN TIME	EVEN SYMBOLS PHASE CHANGE (+j $\omega$ )	ODD SYMBOLS PHASE CHANGE (+j $\omega$ )
00	0	$\pi$
01	$\pi/2$	$3\pi/2$ (- $\pi/2$ )
11	$\pi$	0
10	$3\pi/2$ (- $\pi/2$ )	$\pi/2$

TABLE 7. 5.5Mbps CCK ENCODING TABLE

d2, d3	CHIPS							
00	1j	1	1j	-1	1j	1	-1j	1
01	-1j	-1	-1j	1	1j	1	-1j	1
10	-1j	1	-1j	-1	-1j	1	1j	1
11	1j	-1	1j	1	-1j	1	1j	1

At 11Mbps, eight bits (d0–d7; d0 first in time) are transmitted per symbol.

The first dibit (d0, d1) encodes the phase  $\varphi_1$  based on DQPSK. The DQPSK encoder is specified in Table 6 above. The phase change for  $\varphi_1$  is relative to the phase  $\varphi_1$  of the preceding symbol. In the case of rate change, the phase change for  $\varphi_1$  is relative to the phase  $\varphi_1$  of the preceding CCK symbol. All odd numbered symbols of the MPDU are given an extra 180 degree ( $\pi$ ) rotation in accordance with the

DQPSK modulation as shown in Table 8. Symbol numbering starts with "0" for the first symbol of the MPDU.

The data dibits: (d2, d3), (d4, d5), (d6, d7) encode  $\varphi_2$ ,  $\varphi_3$ , and  $\varphi_4$  respectively based on QPSK as specified in Table 8. Note that this table is binary, not Grey, coded.

TABLE 8. QPSK ENCODING TABLE

DIBIT PATTERN (d(i), d(i+1)) d(i) IS FIRST IN TIME	PHASE
00	0
01	$\pi/2$
10	$\pi$
11	$3\pi/2$ (- $\pi/2$ )

### TX Power Control

The transmitter power can be controlled by the MAC via two registers. The first register, CR58, contains the results of power measurements digitized by the HFA3863. By comparing this measurement to what the MAC needs for transmit power, the MAC can determine whether to raise or lower the transmit power. It does this by writing the power level desired to register CR31.

### Clear Channel Assessment (CCA) and Energy Detect (ED) Description

The clear channel assessment (CCA) circuit implements the carrier sense portion of a carrier sense multiple access (CSMA) networking scheme. The CCA monitors the environment to determine when it is clear to transmit. The CCA circuit in the HFA3863 can be programmed to be a function of RSSI (energy detected on the channel), CS1, SQ1, or various combinations. The CCA output goes to the MAC. The MAC decides on transmission based on traffic to send and the CCA indication. The CCA indication can be ignored, allowing transmissions independent of any channel conditions. The CCA in combination with the visibility of the various internal parameters (i.e., Energy Detection measurement results), can assist the MAC in executing algorithms that can adapt to the environment. These algorithms can increase network throughput by minimizing collisions and reducing transmissions liable to errors.

There are three measures that can be used in the CCA assessment. The receive signal strength indication (RSSI) which indicates the energy at the antenna, CS1 and carrier sense (SQ1). CS1 becomes active anytime the AGC portion of the circuit becomes unlocked, which is likely at the onset of a signal that is strong enough to support 11Mbps, but may not occur with the onset of a signal that is only strong enough to support 1 or 2Mbps. CS1 stays active until the AGC locks and a SQ1 assessment is done, if SQ1 is false, then CS1 is cleared, which deasserts CCA. If SQ1 is true, then tracking is begun, and CCA continues to show the channel busy. CS1 may occur at any time during acquisition

as the AGC state machine runs asynchronously with respect to slot times.

SQ1 becomes active only when a spread signal with the proper PN code has been detected, and the peak correlation amplitude to sidelobe ratio exceeds a set threshold, so it may not be adequate in itself.

A SQ1 evaluation occurs whenever the AGC has remained locked for the entire data ingest period. When this happens, SQ1 is updated between 8 and 9 $\mu$ s into the 10 $\mu$ s dwell. If CS1 is not active, two consecutive SQ1s are required to advance the part to tracking.

The state of CCA is not guaranteed from the time RX\_PE goes high until the first CCA assessment is made. At the end of a packet, after RXPE has been deasserted, the state of CCA is also not guaranteed.

The receive signal strength indication (RSSI) measurement is derived from the state of the AGC circuit. ED is the comparison result of RSSI against a threshold. The threshold may be set to an absolute power value, or it may be set to be N dB above the measured noise floor. See CR 35. The HFA3863 measures and stores the RSSI level when it detects no presence of BPSK or QPSK signals. The average value of a 256 value buffer is taken to be the noise floor. Thus, the value of the noise floor will adapt to the environment. A separate noise floor value is maintained for each antenna. An initial value of the noise floor is established within 50 $\mu$ s of the chip being active and is refined as time goes on. Deasserting RX\_PE does not corrupt the learned values. If the absolute power metric is chosen, this threshold is normally set to between -70 and -80dBm.

If desired, ED may be used in the acquisition process as well as CCA. ED may be used to mask (squell) weak signals and prevent radio reception of signals too weak to support the high data rates, signals from adjacent cells, networks, or buildings.

The Configuration registers effecting the CCA algorithm operation are summarized below (more programming details on these registers can be found under the Control Registers section of this document).

The CCA output from pin 60 of the device can be defined as active high or active low through CR 1 (bit 2).

CR9(6:5) allow CCA to be programmed to be a function of ED only, the logical operation of (CS1 OR SQ1), the logical function of (ED AND (CS1 OR SQ1)), or (ED OR (CS1 OR SQ1)).

CR9(7) lets the user select from sampled CCA mode, which means CCA will not glitch, is updated once per symbol and is valid for reading at 15.8 $\mu$ s or 18.7 $\mu$ s. In non-sampled mode, CCA may change at any time, potentially several times per slot, as ED and CS1 operate asynchronously to slot times.

In a typical system CCA will be monitored to determine when the channel is clear. Once the channel is detected busy, CCA should be checked periodically to determine if the channel becomes clear. Once MD\_RDY goes active, CCA should be ignored for the remainder of the message. Failure to monitor CCA until MD\_RDY goes active (or use of a time-out circuit) could result in a stalled system as it is possible for the channel to be busy and then become clear without an MD\_RDY occurring.

### **AGC Description**

The AGC system consists of the 3 chips handling the receive signal, the RF to IF downconverter HFA3683, the IF to baseband converter HFA3783, and the baseband processor. The AGC loop (Figure 6) is digitally controlled by the BBP. Basically it operates as follows:

Initially, the receiver is set for high gain. The percent of time that the A/D converters in the baseband processor are saturated is monitored along with signal amplitude and the gain is adjusted down until the amplitude is what will optimize the demodulator's performance. If the amount of saturation is great, the initial gain adjust steps are large. If the signal overload is small, they are less. When the gain is about right and the A/Ds' outputs are within the lock window (CR19), the BBP declares AGC lock and stops adjusting for the duration of the packet. If the signal level then varies more than a preset amount (CR20, CR29), the AGC is declared unlocked and the gain again allowed to readjust.

The BBP looks for the locked state following an unlocked state (CS1) as one indication that a received signal is on the antenna. This starts the receive process of looking for PN correlation (SQ1). Once PN correlation and AGC lock are found, the processor begins acquisition.

For large signals, the power level in the RF stage output is also monitored and if it is large, the LNA stage is shut down. This removes 30dB of gain from the receive chain which is compensated for by replacing 30dB of gain in the IF AGC stage. There is some hysteresis in this operation and once the AGC locks, it is locked as well. This improves the receiver dynamic range.

### **rxRfAGC Pad Operation**

#### **30dB Pad Engaging (RF Chip Low Gain):**

If the AGC is not locked onto a packet, a '1' on the ifCompDet input will engage in the 30dB attenuation pad. This causes the AGC to go out of lock and also forces the attenuation accumulator to be set to the programmed value of CR27. The AGC then attempts to lock on the signal.

If the AGC is locked on a packet, ifCompDet is ignored.



**30dB Pad Releasing (RF Chip High Gain):**

If the AGC is not locked onto a packet and the attenuation accumulator sum falls below the programmable threshold (CR27), the pad will release. This is for the case where a noise spike kicked in the 30dB pad and the pad should release when the noise spike ends. Since the noise floor is different for different environments, it is possible that in many cases CR27's programmed value will be below the noise floor and the pad will not be removed except by RXPE going low. There is a recommended value to program CR27 (24dB), but that depends on what environment the radio is in.

During a packet (after AGC lock), the 30dB pad is held constant and the CR27 threshold is ignored.

RXPE low forces the pad to release whether in the middle of a packet or not. At the end of a packet, RXPE always goes low, forcing the pad to release.

NOTE: The attenuation accumulator is basically about equal to the current RSSI value.

The accumulator output, after going thru the interpolator lookup table, feeds the AGC D/A.

The pad value is programmable (CR17), but is recommended to be set to 30dB.

**ifCompDet** is a signal from the HFA3783 chip. A '1' indicates its inputs are near saturation and it needs the RF chip to switch from high gain to low gain.

**RxIfDet** is the input to the HFA3863 chip connected to **ifCompDet**.

**rxRfAGC** is the output of the HFA3863 chip and '1' is high gain, '0' is low gain.

**Demodulator Description**

The receiver portion of the baseband processor, performs A/D conversion and demodulation of the spread spectrum signal. It correlates the PN spread symbols, then demodulates the DBPSK, DQPSK, or CCK symbols. The demodulator includes a frequency tracking loop that tracks and removes the carrier frequency offset. In addition, it tracks the symbol timing, and differentially decodes and descrambles the data. The data is output through the RX Port to the external processor.

The PRISM baseband processor, HFA3863 uses differentially coherent demodulation. The HFA3863 is designed to achieve rapid settling of the carrier tracking loop during acquisition. Rapid phase fluctuations are handled with a relatively wide loop bandwidth which is then stepped down as the packet progresses. Coherent processing improves the BER performance margin as opposed to differentially coherent processing for the CCK data rates.

The baseband processor uses time invariant correlation to strip the Barker code spreading and phase processing to demodulate the resulting signals in the header and

DBPSK/DQPSK demodulation modes. These operations are illustrated in Figure 13 which is an overall block diagram of the receiver processor.

In processing the DBPSK header, input samples from the I and Q A/D converters are correlated to remove the spreading sequence. The peak position of the correlation pulse is used to determine the symbol timing. The sample stream is decimated to the symbol rate and corrected for frequency offset prior to PSK demodulation. Phase errors from the demodulator are fed to the NCO through a lead/lag filter to maintain phase lock. The carrier is de-rotated by the carrier tracking loop. The demodulated data is differentially decoded and descrambled before being sent to the header detection section.

In the 1Mbps DBPSK mode, data demodulation is performed the same as in header processing. In the 2Mbps DQPSK mode, the demodulator demodulates two bits per symbol and differentially decodes these bit pairs. The bits are then serialized and descrambled prior to being sent to the output.

In the CCK modes, the receiver removes carrier frequency offsets and uses a bank of correlators to detect the modulation. A biggest picker finds the largest correlation in the I and Q Channels and determines the sign of those correlations. For this to happen, the demodulator must know the starting phase which is determined by referencing the data to the last bit of the header. Each symbol demodulated determines one or two nibbles of data. This is then serialized and descrambled before being passed to the output.

Carrier tracking is via a lead/lag filter using a digital Costas phase detector. Chip tracking in the CCK modes is chip decision directed or slaved to the carrier tracking depending on whether or not the locked oscillator **desing** is utilized in the radio.

**Acquisition Description**

A projected worst case time line for the acquisition of a signal with a short preamble and header is shown. The synchronization part of the preamble is 56 symbols long followed by a 16-bit SFD. The receiver must monitor the antenna to determine if a signal is present. The timeline is broken into 10 $\mu$ s blocks (dwells) for the scanning process. This length of time is necessary to allow enough integration of the signal to make a good acquisition decision. This worst case time line example assumes that the signal arrives part way into the first dwell such as to just barely catch detection. The signal and the scanning process are asynchronous and the signal could start anywhere. In this timeline, it is assumed that the signal is present in the first 10 $\mu$ s dwell, but was missed due to power amplifier ramp up.

Meanwhile signal quality and signal frequency measurements are made simultaneous with symbol timing measurements. A CS1 followed by SQ1 active, or two



consecutive SQ1's will cause the part to finish the acquisition phase and enter the tracking phase.

Prior to initial acquisition the NCO is inactive (0Hz) and carrier phase measurement are done on a symbol by symbol basis. After acquisition, coherent DPSK demodulation is in effect. After a brief setup time as illustrated on the timeline, the signal begins to emerge from the demodulator.

It takes seven more symbols to seed the descrambler before valid data is available. This occurs in time for the

SFD to be received. At this time the demodulator is tracking and in the coherent PSK demodulation mode so it will no longer acquire new signals. If a much larger signal overrides the signal being demodulated (a collision), the demodulator will abort the tracking process and attempt to acquire the new signal. Failure to find an SFD within the SFD timeout interval will result in a receiver reset and return to acquisition mode.

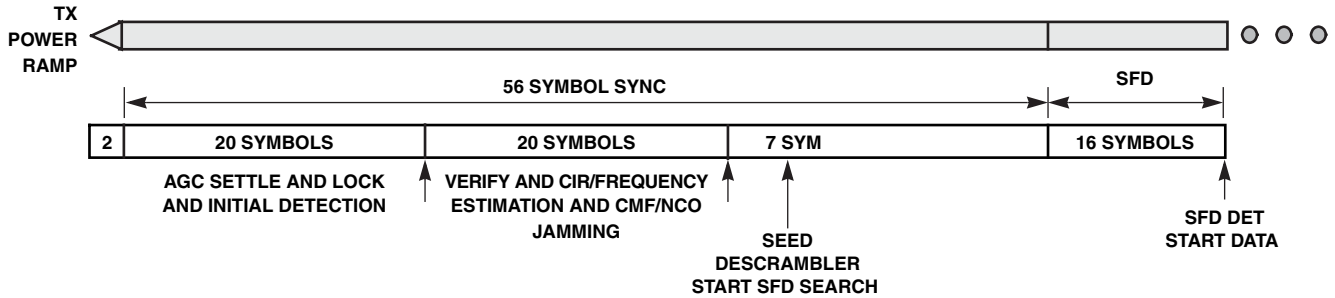

FIGURE 10. ACQUISITION TIMELINE, NON DIVERSITY

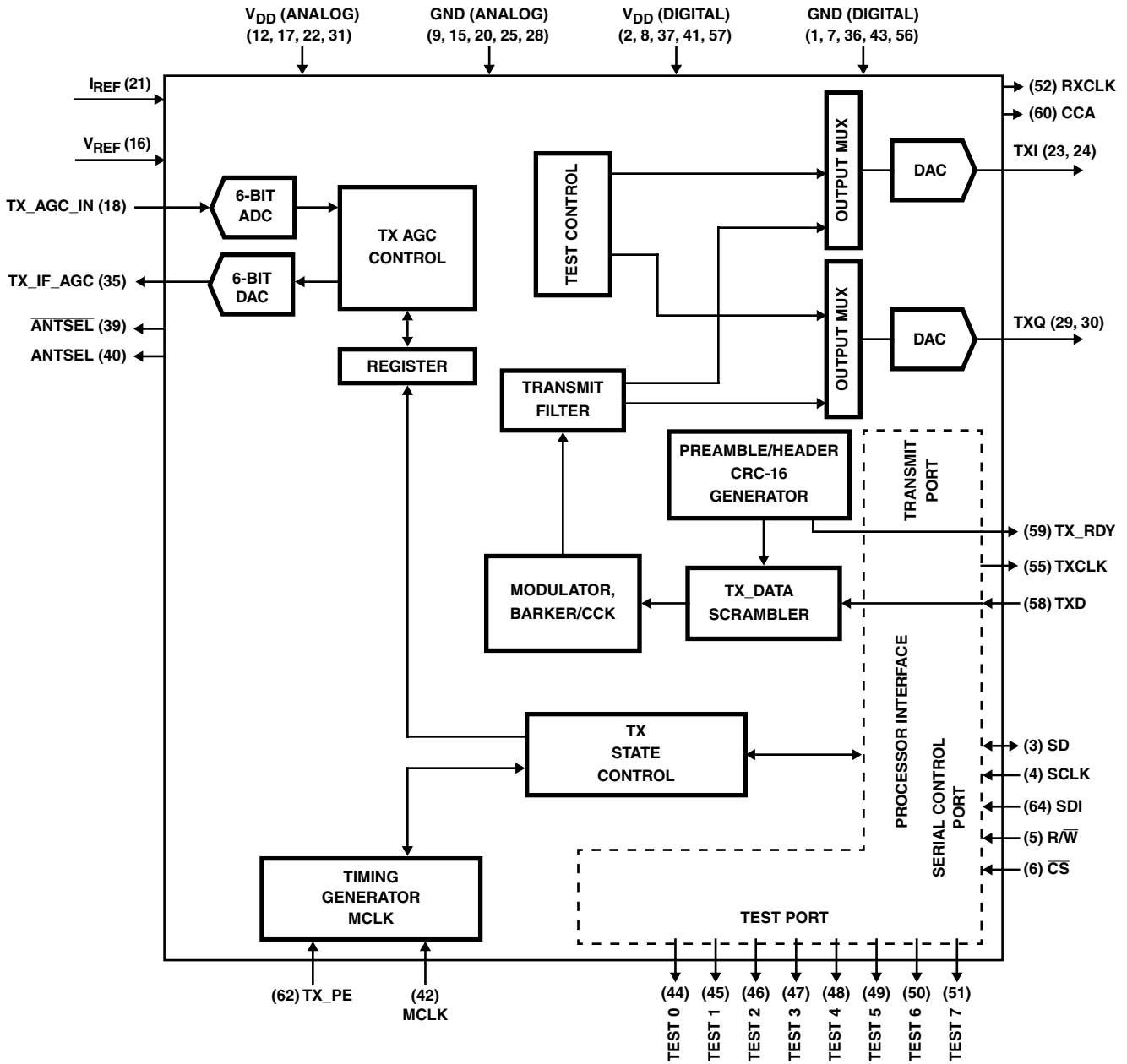

FIGURE 11. DSSS BASEBAND PROCESSOR, TRANSMIT SECTION

### Channel Matched Filter (CMF) Description

The receive section shown in Figure 13 operates on the RAKE receiver principle which maximizes the SNR of the signal by combining the energy of multipath signal components. The RAKE receiver is implemented with a Channel Matched Filter (CMF) using a FIR filter structure with 16 taps. The CMF is programmed by calculating the Channel Impulse Response (CIR) of the channel and mathematically manipulating that to form the tap coefficients of the CMF. Thus, the CMF is set to compensate the channel characteristics that distort the signal. Since the calculation of the CIR is inaccurate at low SNR or in the presence of strong CW interference, the chip has thresholds (CR 36 to 39) that

are set to substitute a default CMF shape under those conditions. This default CMF shape is designed to compensate only the known transmit and receive non linearity.

### PN Correlators Description

There are two types of correlators in the HFA3863 baseband processor. The first is a parallel matched filter correlator that correlates for the Barker sequence used in preamble, header, and PSK data modes. This Barker code correlator is designed to handle BPSK spreading with carrier offsets up to  $\pm 50$ ppm and 11 chips per symbol. Since the spreading is BPSK, the correlator is implemented with two real

correlators, one for the I and one for the Q Channel. The same Barker sequence is always used for both I and Q correlators.

These correlators are time invariant matched filters otherwise known as parallel correlators. They use one sample per chip for correlation although two samples per chip are processed. The correlator despreads the samples from the chip rate back to the original symbol rate giving 10.4dB processing gain for 11 chips per symbol. While despreading the desired signal, the correlator spreads the energy of any non correlating interfering signal.

The second form of correlator is the parallel correlator bank used for detection of the CCK modulation. For the CCK modes, the 64 wide bank of parallel correlators is implemented with a Fast Walsh Transform to correlate the 4 or 64 code possibilities. This greatly simplifies the circuitry of the correlation function. It is followed by a biggest picker which finds the biggest of 4 or 64 correlator outputs depending on the rate. This is translated into two or six data bits. The detected output is then processed through the differential phase decoder to demodulate the last two bits of the symbol.

**Data Demodulation and Tracking Description (DBPSK and DQPSK Modes)**

The signal is demodulated from the correlation peaks tracked by the symbol timing loop (bit sync) as shown in Figure 8. The frequency and phase of the signal is corrected using the NCO that is driven by the phase locked loop. Averaging the phase errors over ten symbols gives the necessary frequency information for seeding the NCO operation.

**Data Decoder and Descrambler Description**

The data decoder that implements the desired DQPSK coding/decoding as shown in Table 9. The data is formed into pairs of bits called dibits. The left bit of the pair is the first in time. This coding scheme results from differential coding of the dibits. Vector rotation is counterclockwise for a positive phase shift, but can be reversed with bit 7 or 6 of CR1.

For DBPSK, the decoding is simple differential decoding.

TABLE 9. DQPSK DATA DECODER

PHASE SHIFT	DIBIT PATTERN (D0, D1) D0 IS FIRST IN TIME
0	00
+90	01
+180	11
-90	10

The data scrambler and de-scrambler are self synchronizing circuits. They consist of a 7-bit shift register with feedback of some of the taps of the register. The scrambler is designed to ensure smearing of the discrete spectrum lines produced by the PN code.

One thing to keep in mind is that both the differential decoding and the descrambling cause error extension or burst errors. This is due to two properties of the processing. First, the differential decoding process causes errors to occur on pairs of symbols. When a symbol's phase is in error, the next symbol will also be decoded wrong since the data is encoded in the change in phase from one symbol to the next. Thus, two errors are made on two successive symbols. Therefore up to four bits may be wrong although on the average only two are. In QPSK mode, these may occur next to one another or separated by up to two bits. In the CCK mode, when a symbol decision error is made, up to six bits may be in error although on average only three bits will be in error. Secondly, when the bits are processed by the descrambler, these errors are further extended. The descrambler is a 7-bit shift register with two taps exclusive or'ed with the bit stream. Thus, each error is extended by a factor of three. Multiple errors can be spaced the same as the tap spacing, so they can be canceled in the descrambler. In this case, two wrongs do make a right. Given all that, if a single error is made the whole packet is discarded anyway, so the error extension property has no effect on the packet error rate. It should be taken into account if a forward error correction scheme is contemplated.

Descrambling is self synchronizing and is done by a polynomial division using a prescribed polynomial. A shift register holds the last quotient and the output is the exclusive-or of the data and the sum of taps in the shift register.

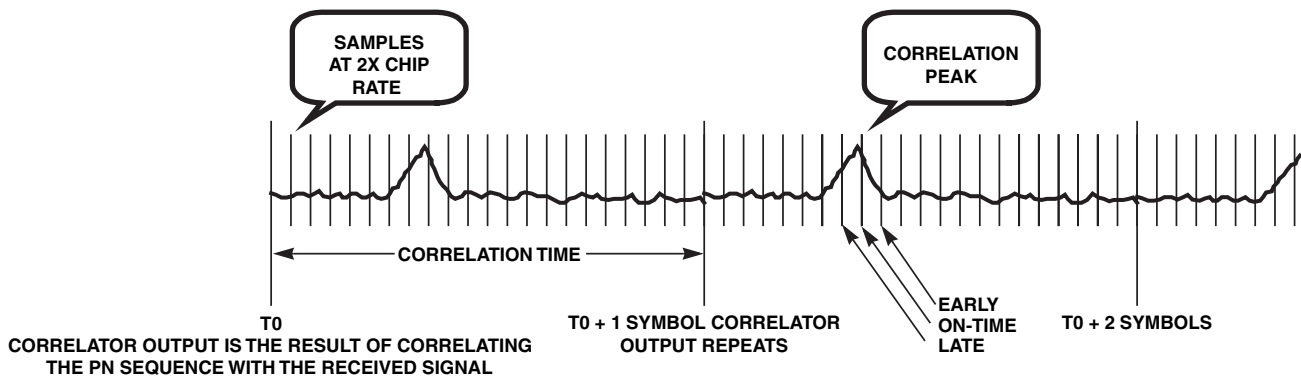

FIGURE 12. CORRELATION PROCESS

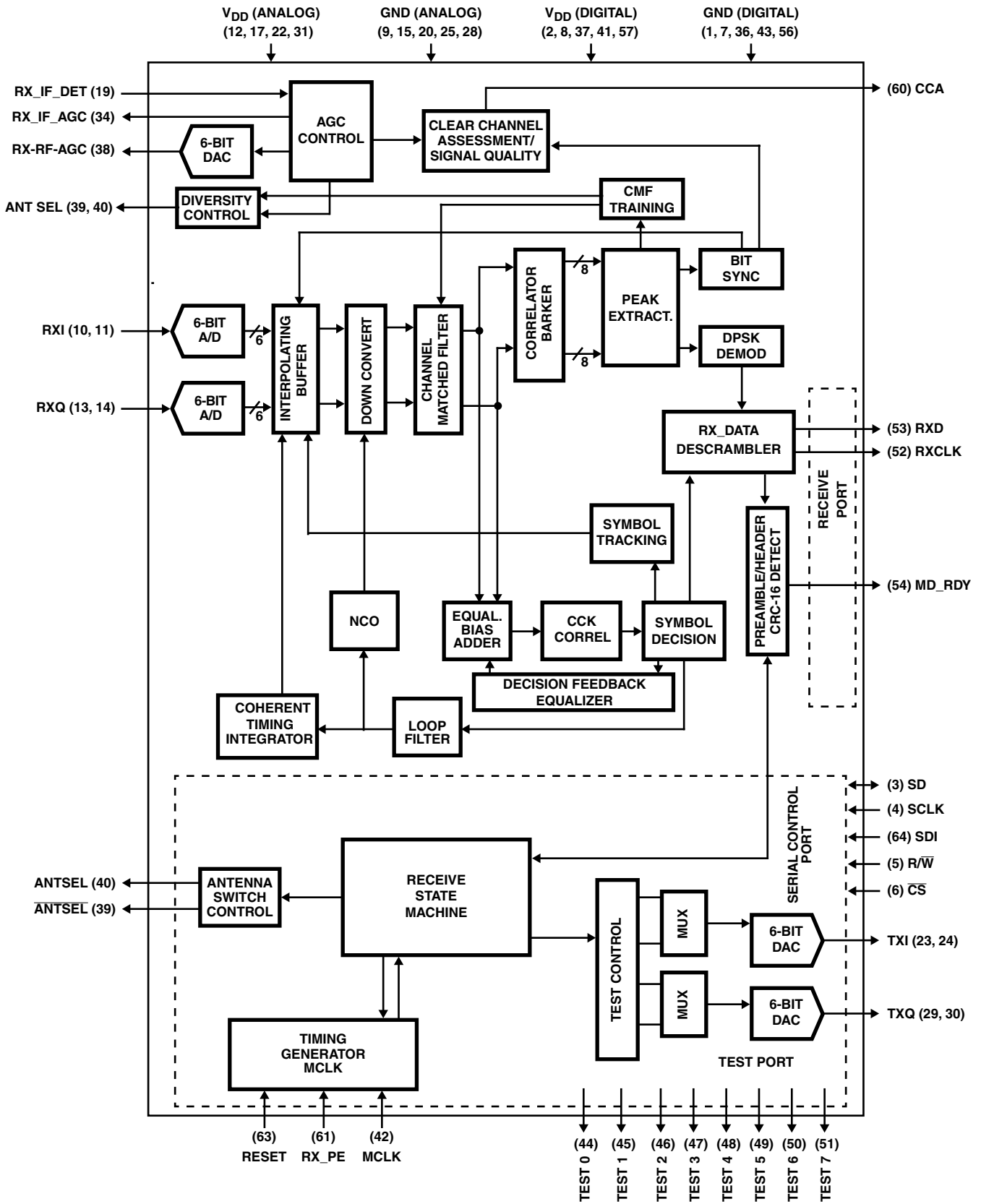

FIGURE 13. DSSS BASEBAND PROCESSOR, RECEIVE SECTION

## Data Demodulation in the CCK Modes

In this mode, the demodulator uses complementary code keying (CCK) modulation for the two highest data rates. It is slaved to the low rate processor which it depends on for acquisition of initial timing and phase tracking information. The low rate section acquires the signal, locks up symbol and carrier tracking loops, and determines the data rate to be used for the MPDU data.

The demodulator for the CCK modes takes over when the preamble and header have been acquired and processed. On the last bit of the header, the phase of the signal is captured and used as a phase reference for the high rate differential demodulator.

The signal from the A/D converters is carrier frequency and phase corrected by a DESPIN stage. This removes the frequency offset and aligns the I and Q Channels properly for the correlators. The sample rate is decimated to 11MSPS for the correlators after the DESPIN since the data is now synchronous in time.

The demodulator knows the symbol timing, so the correlation is batch processed over each symbol. The correlation outputs from the correlator are compared to each other in a biggest picker and the chosen one determines 6 bits of the symbol. The QPSK phase of the chosen one determines two more bits for a total of eight bits per symbol. Six bits come from which of the 64 correlators had the largest output and the last two are determined from the QPSK differential demod of that output. In the 5.5Mbps mode, only four of the correlator outputs are monitored. This demodulates two bits for which of four correlators had the largest output and two more for the QPSK demodulation of that output for a total of four bits per symbol.

## Equalizer Description

The HFA3863 employs a decision feedback equalizer (DFE) to improve performance in the presence of significant multipath distortion. The DFE combats inter chip interference (ICI) and inter symbol interference (ISI). The equalizer is trained on the sample data collected during the first part of the acquisition after the AGC has settled and the antenna selected. The same data is used for CMF calculations and equalizer training. Once the equalizer has been set up, it is used to process the incoming symbols in a decision feedback manner. After the Fast Walsh transform is performed, the detected symbols are corrected for ICI before the bigger picker where the symbol decision process is performed. Once a symbol has been demodulated, the calculated residual energy from that symbol is subtracted from the incoming data for the next symbol. That corrects for the ISI component. The DFE is not adapted during the packet as the channel impulse response is not expected to vary significantly during that brief time. Register CR10 bits 4 and 5 can disable these equalizers separately.

## Tracking

Carrier tracking is performed on the de-rotated signal samples from the complex multiplier in a four phase Costas loop. This forms the error term that is integrated in the lead/lag filter for the NCO, closing the loop. Tracking is only measured when there is a chip transition. Note that this tracking is dependent on a positive SNR in the chip rate bandwidth.

The symbol clock is tracked by a sample interpolator that can adjust the sample timing forwards and backwards by 72 increments of 1/8th chip. This approach means that the HFA3863 can only track an offset in timing for a finite interval before the limits of the interpolator are reached. Thus, continuous demodulation is not possible.

## Locked Oscillator Tracking

Symbol tracking can be slaved to the carrier offset tracking for improved performance as long as at both the transmitting and the receiving radios, the bit clocks and carrier frequency clocks are locked to common crystal oscillators. A bit carried in the SERVICE field (bit 2) indicates whether or not the transmitter has locked clocks. When the same bit is set at the receiver (CR6 bit 2), the receiver knows it can track the bit clock by counting down the carrier tracking offset. This is much more accurate than tracking the bit clock directly. CR33 bit 6 can enable or disable this capability.

## Demodulator Performance

This section indicates the typical performance measures for a radio design. The performance data below should be used as a guide. In general, the actual performance depends on the application, interference environment, RF/IF implementation and radio component selection.

## Overall Eb/N0 Versus BER Performance

The PRISM chip set has been designed to be robust and energy efficient in packet mode communications. The demodulator uses coherent processing for data demodulation. The figures below show the performance of the baseband processor when used in conjunction with the HFA3783 IF and the PRISM recommended IF filters. Off the shelf test equipment are used for the RF processing. The curves should be used as a guide to assess performance in a complete implementation.

Factors for carrier phase noise, multipath, and other degradations will need to be considered on an implementation by implementation basis in order to predict the overall performance of each individual system.

Figure 14 shows the curves for theoretical DBPSK/DQPSK demodulation with coherent demodulation and descrambling as well as the PRISM performance measured for DBPSK and DQPSK. The theoretical performance for DBPSK and DQPSK are the same as shown on the diagram. Figure 15 shows the theoretical and actual

performance of the CCK modes. The losses in both figures include RF and IF radio losses; they do not reflect the HFA3863 losses alone. The HFA3863 baseband processing losses from theoretical are, by themselves, a small percentage of the overall loss.

The PRISM demodulator performs with an implementation loss of less than 4dB from theoretical in a AWGN environment with low phase noise local oscillators. For the 1 and 2Mbps modes, the observed errors occurred in groups of four and six errors. This is because of the error extension properties of differential decoding and descrambling. For the 5.5 and 11Mbps modes, the errors occur in symbols of four or eight bits each and are further extended by the descrambling. Therefore the error patterns are less well defined.

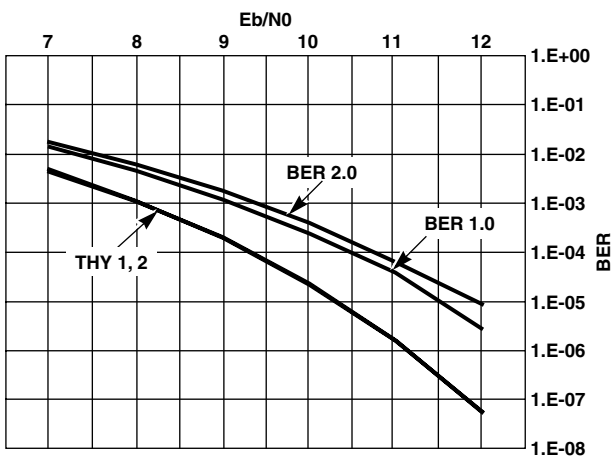

FIGURE 14. BER vs Eb/N0 PERFORMANCE FOR PSK MODES

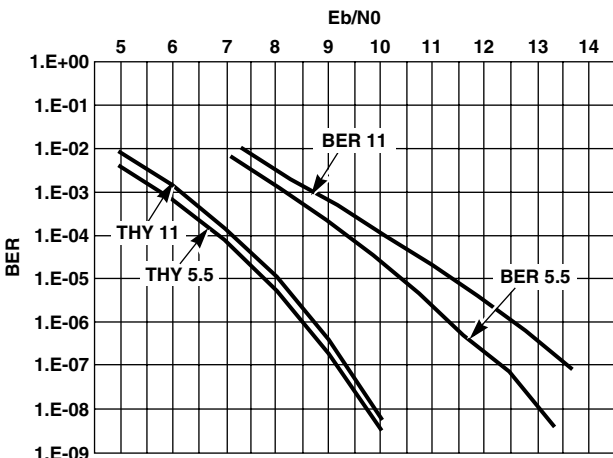

FIGURE 15. BER vs Eb/N0 PERFORMANCE FOR CCK MODES

### Clock Offset Tracking Performance

The PRISM baseband processor is designed to accept data clock offsets of up to  $\pm 25$ ppm for each end of the link (TX and RX). This affects both the acquisition and the tracking performance of the demodulator. The budget for clock offset error is 0.75dB at  $\pm 50$ ppm. No appreciable degradation was seen for operation in AWGN at  $\pm 50$ ppm. Symbol tracking is accomplished by one of two methods. If both ends of the link employ locked oscillators for their bit timing and carrier frequency generation, symbol tracking is done by dividing down the carrier frequency offset. If either one of the ends of the link do not have locked oscillators, then symbol tracking is done by a conventional early-late chip tracking method.

### Carrier Offset Frequency Performance

The correlators used for acquisition for all modes and for demodulation in the 1 and 2Mbps modes are time invariant matched filter correlators otherwise known as parallel correlators. They use two samples per chip and are tapped at every other shift register stage. Their performance with carrier frequency offsets is determined by the phase roll rate due to the offset. For an offset of +50ppm (combined for both TX and RX) will cause the carrier to phase roll 22.5 degrees over the length of the correlator. This causes a loss of 0.22dB in correlation magnitude which translates directly to  $E_b/N_0$  performance loss. In the PRISM chip design, the carrier phase locked loop is inactive during acquisition. During tracking, the carrier tracking loop corrects for offset, so that no degradation is noted. In the presence of high multipath and high SNR, however, some degradation is expected.

### RSSI Performance

The RSSI value is reported on CR62 in hex and is linear with signal level in dB. Figure 16 shows the RSSI curve measured on a whole evaluation radio. This takes into account the full gain adjust range of all radio parts. To get signal level in dBm on a radio, simply subtract the RSSI value in decimal from 100.

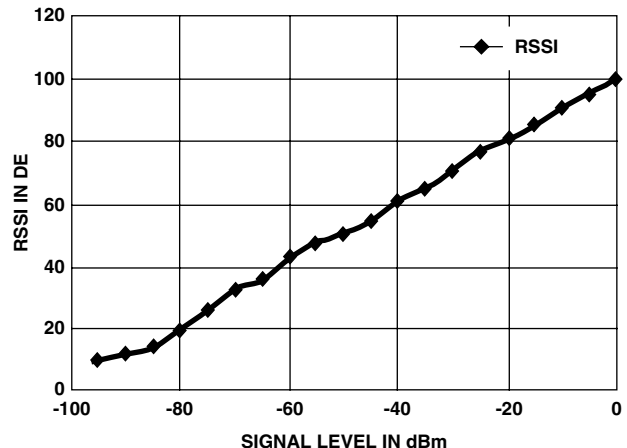

FIGURE 16. RSSI vs SIGNAL LEVEL



### Signal Quality Estimate

A signal quality measure is available on CR51 for use by the MAC. This measure is the SNR in the carrier tracking loop and can be used to determine when the demodulator is working near to the noise floor and likely to make errors. Figure 17 shows the performance of the SQ measure versus signal to noise level.

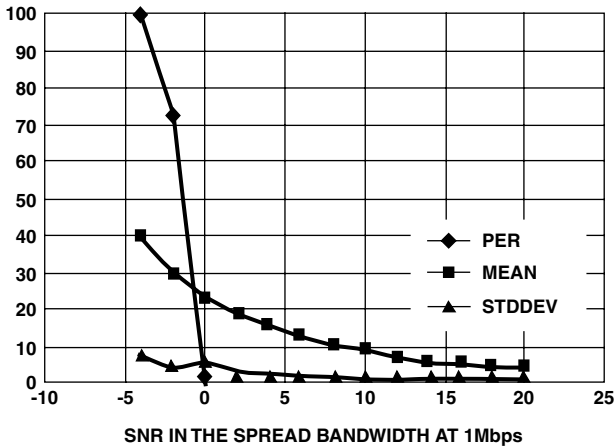

FIGURE 17. SIGNAL QUALITY MEASURE AND PER vs SNR

### ED Threshold

The performance of the ED threshold is shown in Figure 18. Setting this threshold will effect CCA only. Using ED as part of the CCA measure will allow deferral to large signals even if they are not correlated to the desired spread signals.

ED can be read from CR61 bit 4. Using ED and RSSI can assist the MAC in determining the presence of non correlating signals such as frequency hoppers or microwave ovens. For example, the MAC can elect to try to transmit over microwave oven interference but not count the results in rate shifting algorithms.

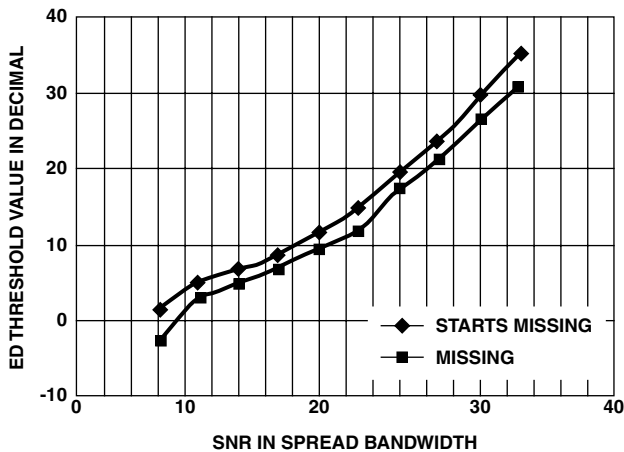

FIGURE 18. ED THRESHOLD vs SNR IN dB AT 1Mbps

### A Default Register Configuration

The registers in the HFA3863 are addressed with 7-bit numbers where the lower 1 bit of an 8-bit hexadecimal address is left as unused. This results in the addresses being in increments of 2 as shown in the table below. Table 10 shows the register values for a default IEEE802.11 configuration with various rate configurations. The data is transmitted as either DBPSK, DQPSK, or CCK depending on the configuration chosen. It is recommended that you start with the simplest configuration (DBPSK) for initial test and verification of the device and/or the radio design. The user can later modify the CR contents to reflect the system and the required performance of each specific application.

TABLE 10. CONTROL REGISTER VALUES FOR DUAL ANTENNA DIVERSITY

CONFIGURATION REGISTER	NAME	TYPE	REGISTER ADDRESS HEX	RECOMMENDED FOR 1/2/5.5/11Mbps
CR0	Part/Version Code	R	00	30
CR1	I/O Polarity	R/W	02	00
CR2	RX Configure	R/W	04	00 <sup>1</sup>
CR3	TX Preamble Length for Short Preamble	R/W	06	38
CR4	TX Preamble Length for Long Preamble	R/W	08	80
CR5	TX Signal Field	R/W	0A	00/01/02/03
CR6	TX Service Field	R/W	0C	04
CR7	TX Length Field, High	R/W	0E	04
CR8	TX Length Field, Low	R/W	10	00
CR9	RX/TX Configure	R/W	12	A2
CR10	RX Configure 1	R/W	14	C8
CR11	RX/TX Configure	R/W	16	03
CR12	A/D Test Modes 1	R/W	18	00
CR13	A/D Test Modes 2	R/W	1A	00
CR14	A/D Test Modes 3	R/W	1C	00
CR15	AGC GainClip	R/W	1E	5C
CR16	AGC Saturation Counts	R/W	20	82
CR17	AGC RxRfpad Value	R/W	22	1E
CR18	AGC HiSat	R/W	24	C7
CR19	AGC LockinLevel/CW Detect Threshold	R/W	26	17
CR20	AGC LockWindow, Pos Side	R/W	28	6A
CR21	AGC Backoff	R/W	2A	12
CR22	AGC Lookup Table Addr and Control	R/W	2C	00
CR23	AGC Lookup Table Data	R/W	2E	00
CR24	AGC LoopGain	R/W	30	2D
CR25	AGC Manual Setting	R/W	32	20
CR26	AGC Test Modes	R/W	34	82
CR27	AGC RX_RF Threshold	R/W	36	18
CR28	AGC Low and Mid SatAtten	R/W	38	79
CR29	AGC LockWindow, Negative Side	R/W	3A	CA
CR30	Carrier Sense 2 Scale Factor	R/W	3C	24
CR31	Manual TX Power Control	R/W	3E	F0
CR32	Test Modes 1	R/W	40	00
CR33	Test Modes 2	R/W	42	00
CR34	Test Bus Address	R/W	44	00
CR35	ED Threshold	R/W	46	7F
CR36	CMF Coefficient Control, Delay Spread	R/W	48	8B
CR37	CW RSSI Threshold	R/W	4A	0F
CR38	SNR Threshold #1	R/W	4C	06
CR39	SNR Threshold #2	R/W	4E	0C
CR40	DC Offset Threshold	R/W	50	0F
CR41	Preamble/Header Tracking Loop Lead Coefficient	R/W	52	2E
CR42	Preamble/Header Tracking Loop Lag Coefficient	R/W	54	20
CR43	Data Tracking Loop Lead Coefficient	R/W	56	10
CR44	Data Tracking Loop Lag Coefficient	R/W	58	10

TABLE 10. CONTROL REGISTER VALUES FOR DUAL ANTENNA DIVERSITY (Continued)

CONFIGURATION REGISTER	NAME	TYPE	REGISTER ADDRESS HEX	RECOMMENDED FOR 1/2/5.5/11Mbps
CR45	False Alarm Rate Scale Factor	R/W	5A	02
CR46	Preamble Timeline Control	R/W	5C	2E
CR47	Acquisition Control	R/W	5E	1E
CR48	Scrambler Seed for Long Preamble	R/W	60	26
CR49	Read Only Register Mux Control For Registers 50 to 63 Scrambler Seed for Short Preamble	R/W	62	5B
CR50	a&b: Test Bus Read	R	64	N/A
CR51	a: Noise floorAntA b: Signal Quality Measure Based on Carrier Tracking	R	66	N/A
CR52	a: Noise floorAntB b: Received Signal Field	R	68	N/A
CR53	a: DC offset I channel b: Received Service Field	R	6A	N/A
CR54	a. DC offset Q Channel b: Received Length Field, Low	R	6C	N/A
CR55	a: Multipath Metric on Last Packet b: Received Length Field, High	R	6E	N/A
CR56	a. Multipath count b: Calculated CRC on Received Header, Low	R	70	N/A
CR57	a. Packet Signal Quality Metric b: Calculated CRC on Received Header, High	R	72	N/A
CR58	b: TX Power Measurement	R	74	N/A
CR59	a: Header Signal Quality Metric b: RX Mean Power	R	76	N/A
CR60	b: RX_IF AGC	R	78	N/A
CR61	b: RX Status Register	R	7A	N/A
CR62	b: RSSI	R	7C	N/A
CR63	b: RX Status Register	R	7E	N/A

NOTE: See CR2 bit 0 description for initialization procedure.

AGC REGISTER SETTINGS

CR22 DECIMAL	CR23 HEX
00	0C
01	10
02	14
03	18
04	1C
05	20
06	24
07	28
08	2E
09	34
10	38
11	3C
12	3F
13	43
14	46
15	48

AGC REGISTER SETTINGS (Continued)

CR22 DECIMAL	CR23 HEX
16	4B
17	50
18	55
19	5A
20	63
21	6D
22	76
23	7F
24	7F
25	7F
26	7F
27	7F
28	7F
29	7F
30	7F
31	7F

## Control Registers

The following tables describe the function of each control register along with the associated bits in each control register.

### CONFIGURATION REGISTER 0 ADDRESS (0h) R PART/VERSION CODE

Bit 7:4	Part Code 3 = HFA3863 series
Bit 3:0	Version Code 0 = 3863 Version

### CONFIGURATION REGISTER 1 ADDRESS (02h) R/W I/O POLARITY

	This register is used to define the phase of clocks and other interface signals. 00h is normal setting.
Bit 7	This control bit selects the phase of the receive carrier rotation sense. Logic 1 = Inverted rotation (CW), Invert Q in. Logic 0 = normal rotation (CCW).
Bit 6	This control bit selects the phase of the transmit carrier rotation sense. Logic 1 = Inverted rotation (CW), Invert Q out. Logic 0 = normal rotation (CCW).
Bit 5	This control bit selects the phase of the transmit output clock (TXCLK) pin. Logic 1 = Inverted TXCLK. Logic 0 = NON-Inverted TXCLK.
Bit 4	This control bit selects the active level of the Transmit Ready (TX_RDY) output which is an output pin at the test port, pin. Logic 1 = TX_RDY Active 0. Logic 0 = TX_RDY Active 1.
Bit 3	This control bit selects the active level of the transmit enable (TX_PE) input pin. Logic 1 = TX_PE Active 0. Logic 0 = TX_PE Active 1.
Bit 2	This control bit selects the active level of the Clear Channel Assessment (CCA) output pin. Logic 1 = CCA Active 1. Logic 0 = CCA Active 0.
Bit 1	This control bit selects the active level of the MD_RDY output pin. Logic 1 = MD_RDY is Active 0. Logic 0 = MD_RDY is Active 1.
Bit 0	This controls the phase of the RX_CLK output. Logic 1 = Invert Clk. Logic 0 = Non-Inverted Clk.

### CONFIGURATION REGISTER 2 ADDRESS (04h) R/W RX CONFIGURE

Write to control, Read to verify control, setup while TX\_PE and RX\_PE are low

Bits 7:1	Reserved.
Bit 0	Initialization. 0 = Normal Operation. 1 = Soft Initialization of learned behavior registers such as DCoffset, NoiseFloor, FAR, RecPacketsNOcs1, and RecPacketsUSEdef. Holds AGC logic reset. At part initialization, must be set, then after CR47 is loaded, cleared.

### CONFIGURATION REGISTER 3 ADDRESS (06h) R/W TX PREAMBLE LENGTH FOR SHORT PREAMBLE

Bits 0–7	This register contains the count for the Preamble length counter for short preambles selected by CR5 bit 3. Setup while TX_PE is low. <b>For IEEE802.11 use 38h.</b> For other than IEEE802.11 applications, in general increasing the preamble length will improve low signal to noise acquisition performance at the cost of greater link overhead. The minimum suggested value is 56d = 38h. A 2 symbol TX power amplifier ramp up is added to programmed value.
----------	---------------------------------------------------------------------------------------------------------------------------------------------------------------------------------------------------------------------------------------------------------------------------------------------------------------------------------------------------------------------------------------------------------------------------------------------------------------------

### CONFIGURATION REGISTER 4 ADDRESS (08h) R/W TX PREAMBLE LENGTH FOR LONG PREAMBLE

Bits 0–7	This register contains the count for the Preamble length counter for long preambles selected with CR5 bit 3 or CR11 bit 4. Setup while TX_PE is low. <b>For IEEE802.11 use 80h.</b> For other than IEEE802.11 applications, in general increasing the preamble length will improve low signal to noise acquisition performance at the cost of greater link overhead. The minimum suggested value is 56d = 38h. A 2 symbol TX power amplifier ramp up is added to programmed value. If you program 128 you get 130.
----------	--------------------------------------------------------------------------------------------------------------------------------------------------------------------------------------------------------------------------------------------------------------------------------------------------------------------------------------------------------------------------------------------------------------------------------------------------------------------------------------------------------------------

## HFA3863

### CONFIGURATION REGISTER 5 ADDRESS (0Ah) R/W TX SIGNAL FIELD

Bits 7:5	R/W but not currently used internally, should be set to zero to ensure compatibility with future revisions.
Bit 4	TX/RX filter / CMF weight select. 0 = US. 1 = Japan.
Bits 3	Select preamble mode. 0 = Normal, long preamble interoperable with 1 and 2Mbps legacy equipment. 1 = short preamble and header mode (optional in IEEE802.11).
Bit 2	Reserved, must be set to 0.
Bits 1:0	TX data Rate. Must be set at least 2 $\mu$ s before needed in TX frame. This selects TX signal field code from the registers above. 00 = DBPSK - 11-chip sequence (1Mbps). 01 = DQPSK - 11-chip sequence (2Mbps). 10 = CCK - 8-chip sequence (5.5Mbps). 11 = CCK - 8-chip sequence (11Mbps).

### CONFIGURATION REGISTER 6 ADDRESS (0Ch) R/W TX SERVICE FIELD

Bits 7:0	Bit 7 may be employed by the MAC in IEEE802.11 situations to resolve an ambiguity in the length field when in the 11Mbps mode. Bit 2 should be set to a 1 where the reference oscillator of the radio is common for both the carrier frequency and the data clock. All other bits should be set to 0 to ensure compatibility.
----------	-------------------------------------------------------------------------------------------------------------------------------------------------------------------------------------------------------------------------------------------------------------------------------------------------------------------------------

### CONFIGURATION REGISTER 7 ADDRESS (0Eh) R/W TX LENGTH FIELD (HIGH)

Bits 7:0	This 8-bit register contains the higher byte (bits 8–15) of the transmit Length Field described in the Header. This byte combined with the lower byte indicates the number of microseconds the data packet will take.
----------	-----------------------------------------------------------------------------------------------------------------------------------------------------------------------------------------------------------------------

### CONFIGURATION REGISTER 8 ADDRESS (10h) R/W TX LENGTH FIELD (LOW)

Bits 7:0	This 8-bit register contains the lower byte (bits 0–7) of the transmit Length Field described in the Header. This byte combined with the higher byte indicates the number of microseconds the data packet will take.
----------	----------------------------------------------------------------------------------------------------------------------------------------------------------------------------------------------------------------------

### CONFIGURATION REGISTER 9 ADDRESS (12h) R/W TX CONFIGURE

Bit 7	CCA sample mode time. 0 = 18.7 $\mu$ s. 1 = 15.8 $\mu$ s.
Bits 6:5	CCA mode. 00 - CCA is based only on ED. 01 - CCA is based on (CS1 OR SQ1). 10 - CCA is based on (ED AND (CS1 OR SQ1)). 11 - CCA is based on (ED OR (CS1 OR SQ1)).
Bit 4	TX test modes. 0 = Alternating bits for carrier suppression test. (Needs scrambler off (CR32 [2] = 1)). 1 = all chips set to 1 for CW carrier. This allows frequency measurement.
Bit 3	Enable TX test modes. 0 = normal operation. 1 = Invoke tests described by bit 4.
Bit 2	Antenna choice for TX when TX antenna diversity is disabled. 0 = Set AntSel low. 1 = Set AntSel high.
Bit 1	TX Antenna Mode. 0 = Disable diversity, set AntSel pin to value in bit 2. 1 = Enable diversity, set AntSel pin to antenna for which last valid received header CRC occurred.
Bit 0	High Rate cover code disable. 0 = Enable. 1 = Disable.

**CONFIGURATION REGISTER 10 ADDRESS (14h) R/W RX CONFIGURE**

Bit 7	AGC freeze during packet. 0 = Disable (do not disable unless MAC can handle baseband processor aborting during MPDU reception). 1 = Enable.
Bit 6	CIR estimate/ Dot product clock control. 0 = on during acquisition. 1 = only on after detect.
Bit 5	ISI equalizer control. 0 = enable equalizer. 1 = disable equalizer.
Bit 4	ICI equalizer control. 0 = enable equalizer. 1 = disable equalizer.
Bit 3	MD_RDY control. 0 = After CRC16. 1 = After SFD.
Bit 2	Slot diversity mode control. 0 = disabled, Antenna diversity on for entire slot. 1 = enabled, Antenna diversity disabled for last half of slot - saves acquisition time, use in system where nodes are slot aligned.
Bit 1	Antenna choice for Receiver when single antenna acquisition is selected. 0 = Antenna select pin low. 1 = Antenna select pin high.
Bit 0	Single or dual antenna acquire. 0 = dual antenna for diversity acquisition. 1 = single antenna.

**CONFIGURATION REGISTER 11 ADDRESS (16h) R/W RX-TX CONFIGURE**

Bit 7	Continuous internal RX 22 and 44MHz clocks; (Only Reset active will stop). 0 = normal. 1 = continuous, overrides CR10 bit 6.
Bit 6	A/D input coupling. 0 = DC. 1 = AC (external bias network required).
Bit 5	Reserved.
Bit 4	Short Preamble test mode. 0 = use CR3 for short preamble. 1 = run TX and RX short preamble using preamble length in CR4.
Bit 3	CCA mode. 0 = normal (raw) mode CCA. CCA will immediately respond to changes in ED, CS1, and SQ1 as configured. 1 = Sampled mode CCA. CCA will update once per slot (20µs), will be valid at 18.7µs or 15.8µs as determined by CR9 bit 7.
Bits 2:0	Precursor value in CIR estimate.

**CONFIGURATION REGISTER 12 ADDRESS (18h) R/W A/D TEST MODES 1**

Bit 7	All DAC and A/D clock source control. 0 = normal internal clocks. 1 = clock via SDI pin.
Bit 6	TX DAC clock. 0 = enable. 1 = disable.
Bit 5	RX DAC clock. 0 = enable. 1 = disable.
Bit 4	I DAC clock. 0 = enable. 1 = disable.



**CONFIGURATION REGISTER 12 ADDRESS (18h) R/W A/D TEST MODES 1 (Continued)**

Bit 3	Q DAC clock. 0 = enable. 1 = disable.
Bit 2	RF A/D clock. 0 = enable. 1 = disable.
Bit 1	I A/D clock. 0 = enable. 1 = disable.
Bit 0	Q A/D clock. 0 = enable. 1 = disable.

**CONFIGURATION REGISTER 13 ADDRESS (1Ah) R/W A/D TEST MODES 2**

Bit 7	Standby. 1 = enable. 0 = disable.
Bit 6	SLEEPTX. 1 = enable. 0 = disable.
Bit 5	SLEEP RX. 1 = enable. 0 = disable.
Bit 4	SLEEP IQ. 1 = enable. 0 = disable.
Bit 3	Analog TX Shut_down. 1 = enable. 0 = disable.
Bit 2	Analog RX Shut_down. 1 = enable. 0 = disable.
Bit 1	Analog Standby. 1 = enable. 0 = disable.
Bit 0	Enable manual control of mixed signal power down signals using bits 1:7. 1 = enable. 0 = disable, normal operation (devices controlled by RESET, TX_PE, RX_PE).

**CONFIGURATION REGISTER 14 ADDRESS (1Ch) R/W A/D TEST MODES 3**

Bit 7	Digital format, select output of I/Q and RF A/D converters. 0 = 2s complement. 1 = binary.
Bits 6:4	I/Q DAC input control. This DAC gives an analog look at various internal digital signals that are suitable for analog representation. 000 = normal (TX filter). 001 = down converter output. 010 = E/L integrator - upper six bits of the TCHIPacc on (Q) and zeros on (I). 011 = I/ Q A/Ds. 100 = Bigger picker output. Upper 6 bits of FWT_I winner and FWT_Q winner. 101 = CMF weights - upper 6 bits of all 16 CMF weights are circularly shifted with full scale negative sync pulse interleaved between them. 110 = Test Bus pins (5:0) when configured as inputs, CR32(4), ((5:0) to both I and Q inputs). 111 = Barker Correlator/ low rate samples - as selected by bit 7 CR32.

**CONFIGURATION REGISTER 14 ADDRESS (1Ch) R/W A/D TEST MODES 3 (Continued)**

Bit 3	Enable test bus into RX and TX DAC (if below bit 2 is 0). 0 = normal. 1 = enable.
Bit 2	Enable RF A/D into RX DAC. 0 = normal. 1 = enable.
Bit 1	VRbit1.
Bit 0	VRbit0.

**CONFIGURATION REGISTER 15 ADDRESS (1Eh) R/W AGC GAIN CLIP**

Bit 7	R/W but not currently used internally, should be set to zero to ensure compatibility with future revisions.
Bits 6:0	AGC gain clip (7-bit value, 0-127) this is the attenuator accumulator upper limit. The lower limit is 0.

**CONFIGURATION REGISTER 16 ADDRESS (20h) R/W AGC SATURATION COUNTS**

Bits 7:4	AGC mid Saturation counts (0–15 range) these are the counts to kick in the low and mid attenuator steps (CR28).
Bits 3:0	AGC low Saturation Count (0–15 range).

**CONFIGURATION REGISTER 17 ADDRESS (22h) R/W AGC RF PAD VALUE**

Bit 7:6	R/W but not currently used internally, should be set to zero to ensure compatibility with future revisions.
Bit 5:0	RXRF_AGC pad value to use in the RSSI calculation, Range 0–63dB (nominally 30dB).

**CONFIGURATION REGISTER 18 ADDRESS (24h) R/W AGC HI SAT**

Bits 7:4	AGC high saturation attenuation value (0–30). NOTE: hi saturation attenuation step actual value is programmed value times 2. This attenuation step will occur if the # of I and Q sats is greater than hi saturation count.
Bits 3:0	AGC hi sat count (0–15 range).

**CONFIGURATION REGISTER 19 ADDRESS (26h) R/W AGC LOCK IN LEVEL**

Bits 7:5	CW detector scale multiplication factor. (xxxx.x). See CR35 and CR 49. Set to 00h for forcing CW detect always active. Set to 0Fh for forcing CW detector always inactive.
Bits 4:0	AGC Lock-in level (0–7.5 range). Note this is the inner lock window.

**CONFIGURATION REGISTER 20 ADDRESS (28h) R/W AGC LOCK WINDOW POS.**

Bits 7:5	AGC max lock count for antenna search. The number of updates required to lock AGC must be less than or equal to this count for antenna diversity search to be allowed to run. Range 0 to 7.
Bit 4:0	AGC Lock Window positive side (0–15.5 range). Note: this is the outer lock window.

**CONFIGURATION REGISTER 21 ADDRESS (2Ah) R/W AGC BACKOFF**

Bits 7,6	R/W but not currently used internally, should be set to zero to ensure compatibility with future revisions.
Bits 5:0	AGC Backoff (xxxx.x, 0–31.5 range) in half dB steps. This sets the operating headroom in the I and Q ADCs.

**CONFIGURATION REGISTER 22 ADDRESS (2Ch) R/W AGC LOOKUP TABLE ADDRESS**

Bits 7,6	R/W but not currently used internally, should be set to zero to ensure compatibility with future revisions.
Bits 5	AGC Look up table read control bit. 1 = Read AGC table at address given below. 0 = Read contents of CR23.
Bits 4:0	AGC lookup table address (32 address bits).

**CONFIGURATION REGISTER 23 ADDRESS (2Eh) R/W AGC TABLE DATA**

Bits 7	R/W but not currently used internally, should be set to zero to ensure compatibility with future revisions.
Bits 6:0	AGC look up table data, unsigned.

**CONFIGURATION REGISTER 24 ADDRESS (30h) R/W AGC LOOP GAIN**

Bits 7	R/W but not currently used internally, should be set to zero to ensure compatibility with future revisions.
Bit 6:0	AGC loop gain (0.xxxx - x.00000, 0 - 1.0000 range), nominally 0.7.

**CONFIGURATION REGISTER 25 ADDRESS (32h) R/W AGC RX\_IF AND RF**

Bits 7	AGC RX_RF, This input drives the RX-RF control if AGC override Enable is set to 1. When Polarity bit (CR26[6]) is zero: 1 = removes 30dB pad. 0 = inserts 30dB pad.
Bits 6:0	AGC RX_IF, This CR is input to RF-IF DAC if AGC override Enable (CR 26[2]) is set to 1.

**CONFIGURATION REGISTER 26 ADDRESS (34h) R/W AGC TEST MODES**

Bits 7	AGC continuous update. 0 = disable, no updates during AGC freeze. 1 = allow updates during freeze AGC and AGC_lock. See also CR17[7].
Bit 6	rxRFAGC polarity control. 0 = normal. 1 = invert.
Bit 5	AGC extra update disable. Allows final 32 sample update tweak after AGC_lock is declared. 0 = enable an extra update. 1 = disable extra update.
Bits 3:4	R/W but not currently used internally, should be set to zero to ensure compatibility with future revisions.
Bit 2	AGC override Enable. 0 = normal, disabled. 1 = enabled, CR25 controls receiver gain in both RF and IF via RXRF_AGC and RXIF_AGC lines.
Bit 1	AGC 2nd antenna power abort. 0 = AGC lock on 2nd antenna is required to finish antenna dwell. 1 = abort 2nd antenna lock search immediately if power is lower on 2nd antenna than on 1st antenna.
Bit 0	AGC Sat Step disable if within CR29[7:5] window. 0 = disable sat step. 1 = enable sat step.

**CONFIGURATION REGISTER ADDRESS 27 (36h) R/W AGC RF THRESHOLD**

Bit 7	RXRF AGC disable. 0 = normal. 1 = disables threshold.
Bits 6:0	RF AGC threshold (0–64 range). The RxRf_Agc pad is removed if the AGC voltage falls below this threshold.

**CONFIGURATION REGISTER ADDRESS 28 (38h) R/W AGC LOW SAT ATTENUATOR**

Bits 7:4	Mid saturation attenuation (0-30 range). NOTE: mid saturation attenuation is programmed as this value times 2. The mid and low attenuator steps will occur if the number of I and Q saturations are greater than the mid and low saturation counts set by CR16.
Bits 3:0	low saturation attenuation (0–15 range).

**CONFIGURATION REGISTER ADDRESS 29 (3Ah) R/W AGC LOCK WINDOW NEGATIVE SIDE**

Bits 7:5	AGC Saturation Block Level, 1xx.x, range 4.0 to 7.5 dB. Disable saturation attenuation step if less than or equal to this level.
Bits 4:0	AGC lock window negative side. (0–15.5 range) (this is the outer lock window) NOTE: set as a positive number, logic will convert to negative.

## HFA3863

### CONFIGURATION REGISTER ADDRESS 30 (3Ch) R/W CARRIER SENSE 2 SCALE FACTOR

Bits 7:6	R/W but not currently used internally, should be set to zero to ensure compatibility with future revisions.
Bit 5:0	Carrier Sense 2 (CS2) scale factor (0–7.875 range) (000000–111111).

### CONFIGURATION REGISTER 31 ADDRESS (3Eh) TX POWER CONTROL

Bits 7:1	Sets the transmit power. 7 bits to DAC input, -64 to 63 range. Note: rising edge of TXPE is required for value in CR 31 to be applied to DAC.
Bit 0	R/W but not currently used internally, should be set to zero to ensure compatibility with future revisions.

### CONFIGURATION REGISTER 32 ADDRESS (40h) R/W TEST MODES 1

Bit 7	Selection bit for DAC input test mode 7. 0 = Barker 1 = Low rate I/Q samples.
Bit 6	force high rate mode. 0 = normal. 1 = force high rate mode.
Bit 5	Length Field counter. 0 = disable (non-EEE802.11 systems, length field may be in bits not microseconds). 1 = enabled.
Bit 4	Tristate test bus and enable inputs. 0 = Normal. 1 = enable inputs on test bus.
Bit 3	Disable spread sequence for 1 and 2Mbps. 0 = Normal. 1 = disabled.
Bit 2	Disable scrambler. 0 = normal scrambler operation. 1 = scrambler disabled (taps set to 0).
Bit 1	PN generator enable (RX 44MHz clock). 0 = not enabled. 1 = enabled. Bit must first be written to a '0' before a '1' to initialize logic.
Bit 0	PN generator enable (RX 22MHz clock). 0 = not enabled. 1 = enabled. Bit must first be written to a '0' before a '1' to initialize logic.

### CONFIGURATION REGISTER ADDRESS 33 (42h) R/W TEST MODES 2

Bit 7	Coherent AGC disable. 0 = normal, enabled. 1 = disable.
Bit 6	Time Tracking Mode. 0 = enable detection of the Service field bit showing that the carrier and bit timing are locked to the same oscillator. 1 = disable detection and force locked time tracking. NOTE: for automatic locked time tracking operation, bit 2 of the received Service field as well as bit 2 of CR6 of the receiver must be a "1".
Bit 5	DC offset compensation control. Final digital DC input offset compensation. 0 = enable DC offset compensation. 1 = disable DC offset compensation.
Bit 4	Bypass I/Q A/Ds. 0 = disable bypass. 1 = 4 MSBs of I/Q data are input on test bus. TESTin 3:0 is [5:2], TESTin 7:4 is Q[5:2], LSBs are zeroed.
Bit 3	disable time adjust during packet. Note: this turns off bit tracking. 0 = normal. 1 = time tracking disabled (overrides bit 6 also).

**CONFIGURATION REGISTER ADDRESS 33 (42h) R/W TEST MODES 2 (Continued)**

Bit 2	Internal digital loop back mode (SDI pin becomes LOCK input to acquisition block). 0 = normal chip operation loop back disabled. 1 = loop back enabled, A/D and D/A converters bypassed, chip will not respond to external signals.
Bit 1	enable PN to lower test bus address (2–0). 0 = normal. 1 = PN to test bus address.
Bit 0	enable PN to upper test bus address (7–3). 0 = normal. 1 = PN to test bus address.

**CONFIGURATION REGISTER ADDRESS 34 (44h) R/W TEST BUS ADDRESS**

Bits 7:0	Address bits for various tests. See Tech Brief #TBD for a description of the factory test modes.
----------	--------------------------------------------------------------------------------------------------

**CONFIGURATION REGISTER ADDRESS 35 (46h) R/W ED THRESHOLD**

Bit 7	Energy Detect Threshold control. 0 = threshold is relative to noise floor. 1 = threshold is absolute.
Bits 6:0	ED Threshold. Range 0–127dBm. RSSI > threshold triggers ED.

**CONFIGURATION REGISTER ADDRESS 36 (48h) R/W DELAY SPREAD THRESHOLD FOR CMF CONTROL**

Bit 7:5	Delay spread count. Range 0–7. Used for evaluation only.
Bits 4:0	Delay spread threshold. 0.xxxx. This and the next three thresholds are used in the following formula to determine which CMF weights to use. CW detect is not configurable. <b>If</b> (CW and RSSI < (CW RSSI threshold + NoiseFloor)) or (no CW and RSSI < (SNR threshold #1 + NoiseFloor)) or (no CW and delay spread < threshold and RSSI < (SNR threshold #2 + NoiseFloor)) <b>then</b> ; use Default CMF weights, <b>else</b> , use Calculated CMF weights.

**CONFIGURATION REGISTER ADDRESS 37 (4Ah) R/W CW RSSI THRESHOLD FOR CMF CONTROL**

Bit 7	R/W but not currently used internally, should be set to zero to ensure compatibility with future revisions.
Bit 6	Force default CMF weights. 0 = normal. 1 = force default CMF weights.
Bit 5	Force calculated CMF weights. 0 = normal. 1 = force calculated CMF weights. Note: this cannot be combined with bit 6. A “1” on both will produce undefined results.
Bits 4:0	CW RSSI threshold, range 0–31dB.

**CONFIGURATION REGISTER ADDRESS 38 (4Ch) R/W SNR THRESHOLD #1 FOR CMF CONTROL**

Bits 7:4	R/W but not currently used internally, should be set to zero to ensure compatibility with future revisions.
Bits 3:0	SNR threshold #1 range 0–15dB.

**CONFIGURATION REGISTER ADDRESS 39 (4Eh) R/W SNR THRESHOLD #2 FOR CMF CONTROL**

Bits 7:4	R/W but not currently used internally, should be set to zero to ensure compatibility with future revisions.
Bits 4:0	SNR threshold #2, range 0–31dB.

**CONFIGURATION REGISTER ADDRESS 40 (50h) R/W DC OFFSET THRESHOLD**

Bits 7:6	R/W but not currently used internally, should be set to zero to ensure compatibility with future revisions.
Bits 5:0	DC offset Threshold, range 0 to 63dB. RSSI > (threshold + NoiseFloor) enables DC offset calculation and compensation.

## HFA3863

### CONFIGURATION REGISTER ADDRESS 41 (52h) R/W PREAMBLE/HEADER LEAD COEFFICIENT

Bit 7:6	R/W but not currently used internally, should be set to zero to ensure compatibility with future revisions.
Bit 5:0	Preamble Lead Coefficient (0–4 range) (000000–100000).

### CONFIGURATION REGISTER ADDRESS 42 (54h) R/W PREAMBLE/HEADER LAG COEFFICIENT

Bit 7:6	R/W but not currently used internally, should be set to zero to ensure compatibility with future revisions.
Bit 5:0	Preamble Lag Coefficient (0–4 range) (000000–100000).

### CONFIGURATION REGISTER ADDRESS 43 (56h) R/W MPDU LEAD COEFFICIENT

Bit 7:6	R/W but not currently used internally, should be set to zero to ensure compatibility with future revisions.
Bit 5:0	Header Lead Coefficient (0–4 range) (000000–100000).

### CONFIGURATION REGISTER ADDRESS 44 (58h) R/W MPDU LAG COEFFICIENT

Bit 7:6	R/W but not currently used internally, should be set to zero to ensure compatibility with future revisions.
Bit 5:0	Header Lag Coefficient (0-4 range) (000000 - 100000).

### CONFIGURATION REGISTER ADDRESS 45 (5Ah) R/W FALSE ALARM RATE OF SQ1

Bits 7:0	False alarm rate of SQ1. Enable/disable with CR47 bit 7. Rate = $N \cdot 32 / 2^{16}$ . For example 01h = 0.05% False Alarm Rate (FAR) and 10h = 0.78% FAR.
----------	----------------------------------------------------------------------------------------------------------------------------------------------------------------

### CONFIGURATION REGISTER ADDRESS 46 (5Ch) R/W ACQUISITION TIMELINE

Bit 7	Long Preamble timeline disable. 0 = enable long preamble timeline processing. 1 = disable long preamble timeline processing (process all preambles as if short).
Bit 6	Long Preamble timeline diversity metric selection. 0 = H factors. 1 = RSSI.
Bits 5:0	SQ1 threshold #2, range 0 to 7.875. (000.00–111.111). Used for verify cycle.

### CONFIGURATION REGISTER ADDRESS 47 (5Eh) R/W ACQUISITION THRESHOLDS

Bit 7	Disable False alarm Rate Processing. 0 = Enable, SQ1 #1 threshold is adjusted in real time by FAR logic. 1 = Disable, SQ1 #1 threshold is set to value of CR 47 (5:0).
Bit 6	ED and SQ2 control for acquisition. 0 = SQ1. 1 = ED and SQ1.
Bits 5:0	SQ1 threshold #1, range 0 to 7.875. (000.00–111.111). Used for initial detect and initial setting for FAR.

### CONFIGURATION REGISTER ADDRESS 48 (60h) R/W SCRAMBLER SEED, LONG PREAMBLE

Bit 7	R/W but not currently used internally, should be set to zero to ensure compatibility with future revisions.
Bit 6:0	Scrambler seed for long preamble. Bit 3 of CR5 selects CR48 or CR49.

### CONFIGURATION REGISTER ADDRESS 49 (62h) R/W SCRAMBLER SEED AND READ ONLY REGISTER MUX CONTROL

Bit 7	Read only register mux control. 0 = READ ONLY registers read 'b' value. 1 = READ ONLY registers read 'a' value.
Bits 6:0	Scrambler seed for short preamble. Bit 3 of CR5 selects CR48 or CR49.

### CONFIGURATION REGISTER ADDRESS 50 (64h) R TEST BUS READ

Bit 7:0	a&b: reads value on test bus.
---------	-------------------------------



## HFA3863

### CONFIGURATION REGISTER ADDRESS 51 (66h) R SIGNAL QUALITY MEASURE

Bit 7:0	a: NOISEfloorAntA [7:0] unsigned, range 0–255. b: measures signal quality based on the SNR in the carrier tracking loop.
---------	-----------------------------------------------------------------------------------------------------------------------------

### CONFIGURATION REGISTER ADDRESS 52 (68h) R RECEIVED SIGNAL FIELD

Bit 7:0	a: NOISEfloorAntB [7:0] unsigned, range 0–255. b: 8-bit value of received signal field.
---------	--------------------------------------------------------------------------------------------

### CONFIGURATION REGISTER ADDRESS 53 (6Ah) R RECEIVED SERVICE FIELD

Bit 7:0	a: I DC offset, signed, sxxxx.xx. b: 8-bit value of received service field.
---------	--------------------------------------------------------------------------------

### CONFIGURATION REGISTER ADDRESS 54 (6Ch) R RECEIVED LENGTH FIELD, LOW

Bit 7:0	a: Q DC offset, signed, sxxxx.xx. b: 8-bit value of received length field, low byte.
---------	-----------------------------------------------------------------------------------------

### CONFIGURATION REGISTER ADDRESS 55 (6Eh) R RECEIVED LENGTH FIELD, HIGH

Bit 7:0	a: Multipath metric, 11111111 (large multipath) to 00000000 (no multipath) on last packet received. b: 8-bit value of received length field, high byte.
---------	------------------------------------------------------------------------------------------------------------------------------------------------------------

### CONFIGURATION REGISTER ADDRESS 56 (70h) R CALCULATED CRC ON RECEIVED HEADER, LOW

Bit 7:0	a: Multipath count. How many of last 15 packets had multipath greater than the programmed threshold (CR36 <7:5>). b: 8-bit value of CRC calculated on header, low byte.
---------	----------------------------------------------------------------------------------------------------------------------------------------------------------------------------

### CONFIGURATION REGISTER ADDRESS 57 (72h) R CALCULATED CRC ON RECEIVED HEADER, HIGH

Bit 7:0	a: Packet signal quality metric. (1, 2, 5.5, 11Mbps) smaller value is poorer quality. Valid for reading after RXPE inactive. b: 8-bit value of CRC calculated on header, high byte.
---------	----------------------------------------------------------------------------------------------------------------------------------------------------------------------------------------

### CONFIGURATION REGISTER ADDRESS 58 (74h) R TX POWER MEASUREMENT

Bit 7:0	a&b: 8-bit value of transmit power measurement (-128 to 127 range) 64 sample average.
---------	---------------------------------------------------------------------------------------

### CONFIGURATION REGISTER ADDRESS 59 (78h) R RX MEAN POWER

Bit 7:0	a: Header Signal Quality Metric. (1, 2Mbps) Smaller value is poorer quality. Valid for reading after RXPE inactive. b: Average power of received signal after log table lookup (0–33 range in dB). Minus 33 is minimum power, 0 is maximum.
---------	------------------------------------------------------------------------------------------------------------------------------------------------------------------------------------------------------------------------------------------------

### CONFIGURATION REGISTER ADDRESS 60 (7Ah) R RX\_IF\_AGC

Bit 7	a&b: unused.
Bits 6:0	a&b: AGC output to the DAC, MSB unused.

### CONFIGURATION REGISTER ADDRESS 61 (7Ch) R RECEIVE STATUS

Bit 7:5	a&b: unused.
Bit 4	a&b: ED, energy detect past threshold.
Bit 3	a&b: TX PWR det Register semaphore - a 1 indicates CR58 has updated since last read.
Bit 2	a&b: AGC_lock - a 1 indicates AGC is within limits of lock window CR20.
Bit 1	a&b: hwStopBHit - a 1 indicates rails hit, AGC updates stopped.
Bit 0	a&b: RX_RF_AGC - status of AGC output to RF chip.

### CONFIGURATION REGISTER ADDRESS 62 (7Eh) R RSSI

Bit 7:0	a&b: 8-bit value of Packet RSSI, unsigned, range 0–255dB.
---------	-----------------------------------------------------------

**CONFIGURATION REGISTER ADDRESS 63 (80h) R RECEIVE STATUS**

Bit 7:6	a&b: signal field value (HRfieldmatch/QPSKwd_OK). 00 = 1. 01 = 2. 10 = 5.5. 11 = 11.
Bit 5	a&b: SFD found.
Bit 4	a&b: Short preamble detected.
Bit 3	a&b: valid signal field found.
Bit 2	a&b: valid CRC 16.
Bit 1	a&b: Antenna selected by receiver when last valid header CRC occurred.
Bit 0	a&b: not used.

**Absolute Maximum Ratings**

Supply Voltage . . . . . 4.0V  
 Input, Output or I/O Voltage . . . . . GND -0.5V to V<sub>CC</sub> +0.5V  
 ESD Classification . . . . . Class 2

**Operating Conditions**

Voltage Range . . . . . +2.70V to +3.60V  
 Temperature Range . . . . . -40°C to 85°C

**Thermal Information**

Thermal Resistance (Typical, Note 3)  $\theta_{JA}$  (°C/W)  
 TQFP Package . . . . . 60  
 Maximum Storage Temperature Range . . . . . -65°C to 150°C  
 Maximum Junction Temperature . . . . . 150°C  
 Maximum Lead Temperature (Soldering 10s) . . . . . 300°C  
 (Lead Tips Only)

**Die Characteristics**

Gate Count . . . . . 200,000 Gates

*CAUTION: Stresses above those listed in "Absolute Maximum Ratings" may cause permanent damage to the device. This is a stress only rating and operation of the device at these or any other conditions above those indicated in the operational sections of this specification is not implied.*

**NOTE:**

- 3.  $\theta_{JA}$  is measured with the component mounted on a low effective thermal conductivity test board in free air (see Tech Brief TB379 for details).

**DC Electrical Specifications** V<sub>CC</sub> = 3.0V to 3.3V ±10%, T<sub>A</sub> = -40°C to 85°C

PARAMETER	SYMBOL	TEST CONDITIONS	MIN	TYP	MAX	UNITS
Power Supply Current	I <sub>CCOP</sub>	V <sub>CC</sub> = 3.6V, CLK Frequency 44MHz (Notes 5, 6, 7)	-	50	60	mA
Standby Power Supply Current	I <sub>CCSB</sub>	V <sub>CC</sub> = Max, Outputs Not Loaded	-	0.5	10	mA
Input Leakage Current	I <sub>I</sub>	V <sub>CC</sub> = Max, Input = 0V or V <sub>CC</sub>	-10	1	10	μA
Output Leakage Current	I <sub>O</sub>	V <sub>CC</sub> = Max, Input = 0V or V <sub>CC</sub>	-10	1	10	μA
Logical One Input Voltage	V <sub>IH</sub>	V <sub>CC</sub> = Max, Min	0.7 V <sub>CC</sub>	-	-	V
Logical Zero Input Voltage	V <sub>IL</sub>	V <sub>CC</sub> = Min, Max	-	-	V <sub>CC</sub> /3	V
Logical One Output Voltage	V <sub>OH</sub>	I <sub>OH</sub> = -1mA, V <sub>CC</sub> = Min	V <sub>CC</sub> -0.2	-	-	V
Logical Zero Output Voltage	V <sub>OL</sub>	I <sub>OL</sub> = 2mA, V <sub>CC</sub> = Min	-	0.1	0.2	V
Input Capacitance	C <sub>IN</sub>	CLK Frequency 1MHz. All measurements referenced to GND. T <sub>A</sub> = 25°C, (Note 5, 6)	-	5	10	pF
Output Capacitance	C <sub>OUT</sub>		-	5	10	pF

**NOTES:**

- 4. Output load 40pF.
- 5. Not tested, but characterized at initial design and at major process/design changes.
- 6. User must allow for a peak current of 100mA that lasts for 20μs when CIR estimate is being calculated.

**AC Electrical Specifications** V<sub>CC</sub> = 3.0V to 3.3V ±10%, T<sub>A</sub> = -40°C to 85°C (Note 8)

PARAMETER	SYMBOL	MCLK = 44MHz		UNITS
		MIN	MAX	
MCLK Period	t <sub>CP</sub>	22.5	-	ns
MCLK Duty Cycle		40/60	60/40	%
Rise/Fall (All Outputs)		-	10	ns (Note 9)
TX_PE to I <sub>OUT</sub> /Q <sub>OUT</sub> (1st Valid Chip)	t <sub>D1</sub>	2.18	2.3	μs (Notes 10)
TX_PE Inactive Width	t <sub>TLP</sub>	2.22	-	μs (Note 11)
TX_CLK Width Hi or Low	t <sub>TCD</sub>	40	-	ns
TX_RDY Active to 1st TX_CLK Hi	t <sub>RC</sub>	260	-	ns
Setup TXD to TX_CLK Hi	t <sub>TDS</sub>	30	-	ns
Hold TXD to TX_CLK Hi	t <sub>TDH</sub>	0	-	ns
TX_CLK to TX_PE Inactive (1Mbps)	t <sub>PEH</sub>	0	965	ns (Note 19)
TX_CLK to TX_PE Inactive (2Mbps)	t <sub>PEH</sub>	0	420	ns (Note 19)
TX_CLK to TX_PE Inactive (5.5Mbps)	t <sub>PEH</sub>	0	160	ns (Note 19)

**AC Electrical Specifications**  $V_{CC} = 3.0V$  to  $3.3V \pm 10\%$ ,  $T_A = -40^{\circ}C$  to  $85^{\circ}C$  (Note 8) (Continued)

PARAMETER	SYMBOL	MCLK = 44MHz		UNITS
		MIN	MAX	
TX_CLK to TX_PE Inactive (11Mbps)	$t_{PEH}$	0	65	ns (Note, 19)
TX_RDY Inactive to Last Chip of MPDU Out	$t_{RI}$	-20	800	ns
TXD Modulation Extension	$t_{ME}$	2	-	$\mu s$ (Note 12)
RX_PE Inactive Width	$t_{RLP}$	70	-	ns (Note 13)
RX_CLK Period (11Mbps Mode)	$t_{RCP}$	90	-	ns
RX_CLK Width Hi or Low (11Mbps Mode)	$t_{RCD}$	44	-	ns
RX_CLK to RXD	$t_{RDD}$	25	60	ns
MD_RDY to 1st RX_CLK	$t_{RD1}$	940	-	ns (Note 16)
RXD to 1st RX_CLK	$t_{RD1}$	940	-	ns
Setup RXD to RX_CLK	$t_{RDS}$	31	-	ns
RX_CLK to RX_PE Inactive (1Mbps)	$t_{REH}$	0	925	ns (Note 14)
RX_CLK to RX_PE Inactive (2Mbps)	$t_{REH}$	0	380	ns (Note 14)
RX_CLK to RX_PE Inactive (5.5Mbps)	$t_{REH}$	0	140	ns (Note 14)
RX_CLK to RX_PE Inactive (11Mbps)	$t_{REH}$	0	50	ns (Note 14)
RX_PE inactive to MD_RDY Inactive	$t_{RD2}$	5	30	ns (Note 15)
Last Chip of SFD in to MD_RDY Active	$t_{RD3}$	2.77	2.86	$\mu s$ (Note 16)
RX Delay		2.77	2.86	$\mu s$ (Note 17)
RESET Width Active	$t_{RPW}$	50	-	ns (Note 18)
RX_PE to CCA Valid	$t_{CCA}$	-	16	$\mu s$
RX_PE to RSSI Valid	$t_{CCA}$	-	16	$\mu s$
SCLK Clock Period	$t_{SCP}$	90	-	ns
SCLK Width Hi or Low	$t_{SCW}$	20	-	ns
Setup to SCLK + Edge (SD, SDI, R/W, CS)	$t_{SCS}$	30	-	ns
Hold Time from SCLK + Edge (SD, SDI, R/W, CS)	$t_{SCH}$	0	-	ns
SD Out Delay from SCLK + Edge	$t_{SCD}$	-	30	ns
SD Out Enable/Disable from R/W	$t_{SCED}$	-	15	ns
TEST 0-7, CCA, ANTSEL, TEST_CK from MCLK	$t_{D2}$	-	40	ns

## NOTES:

- AC tests performed with  $C_L = 40pF$ ,  $I_{OL} = 2mA$ , and  $I_{OH} = -1mA$ . Input reference level all inputs  $V_{CC}/2$ . Test  $V_{IH} = V_{CC}$ ,  $V_{IL} = 0V$ ;  $V_{OH} = V_{OL} = V_{CC}/2$ .
- Not tested, but characterized at initial design and at major process/design changes.
- Measured from  $V_{IL}$  to  $V_{IH}$ .
- $I_{OUT}/Q_{OUT}$  are modulated before first valid chip of preamble is output to provide ramp up time for RF/IF circuits.
- TX\_PE must be inactive before going active to generate a new packet.
- $I_{OUT}/Q_{OUT}$  are modulated after last chip of valid data to provide ramp down time for RF/IF circuits.
- RX\_PE must be inactive at least 3 MCLKs before going active to start a new CCA or acquisition.
- RX\_PE active to inactive delay to prevent next RX\_CLK.
- Assumes RX\_PE inactive after last RX\_CLK.
- MD\_RDY programmed to go active after SFD detect. (Measured from  $I_{IN}$ ,  $Q_{IN}$ .)
- MD\_RDY programmed to go active at MPDU start. Measured from first chip of first MPDU symbol at  $I_{IN}$ ,  $Q_{IN}$  to MD\_RDY active.
- Minimum time to ensure Reset. RESET must be followed by an RX\_PE pulse to ensure proper operation. This pulse should not be used for first receive or acquisition.
- Delay from TXCLK to inactive edge of TXPE to prevent next TXCLK. Because TXPE asynchronously stops TXCLK, TXPE going inactive within 40ns of TXCLK will cause TXCLK minimum hi time to be less than 40ns.

**I and Q A/D AC Electrical Specifications** (Note

)

PARAMETER	MIN	TYP	MAX	UNITS
Full Scale Input Voltage ( $V_{P-P}$ )	0.25	0.50	1.0	V
Input Bandwidth (-0.5dB)	-	20	-	MHz
Input Capacitance	-	5	-	pF
Input Impedance (DC)	5	-	-	k $\Omega$
FS (Sampling Frequency)	-	-	22	MHz

NOTE:

20. Not tested, but characterized at initial design and at major process/design changes.

**Test Circuit**

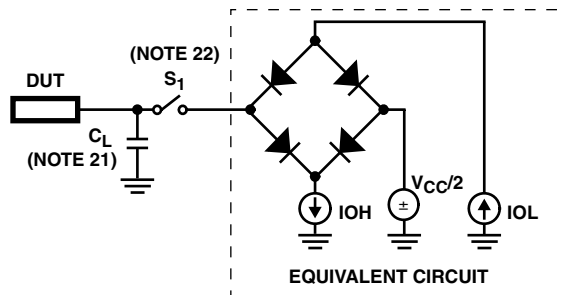

NOTES:

21. Includes Stray and JIG Capacitance.

22. Switch  $S_1$  Open for  $I_{CCSB}$  and  $I_{CCOP}$ .

FIGURE 19. TEST LOAD CIRCUIT

**Waveforms**

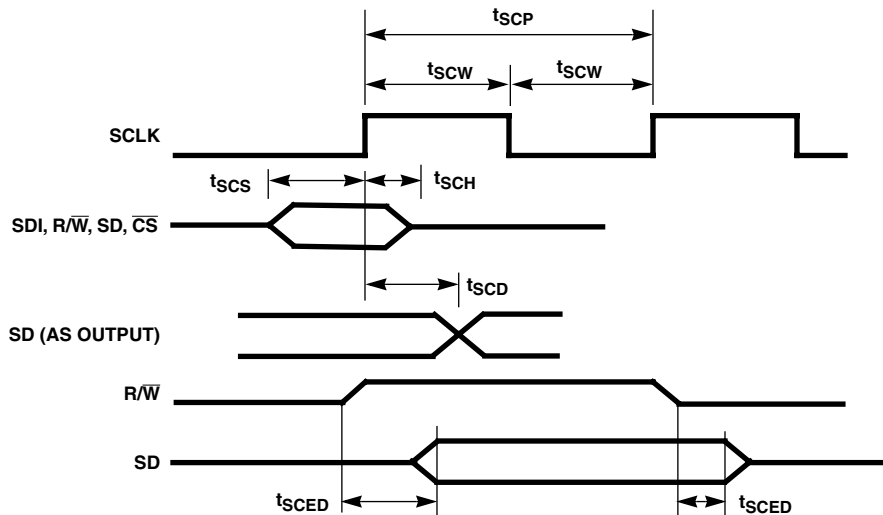

FIGURE 20. SERIAL CONTROL PORT SIGNAL TIMING

Waveforms (Continued)

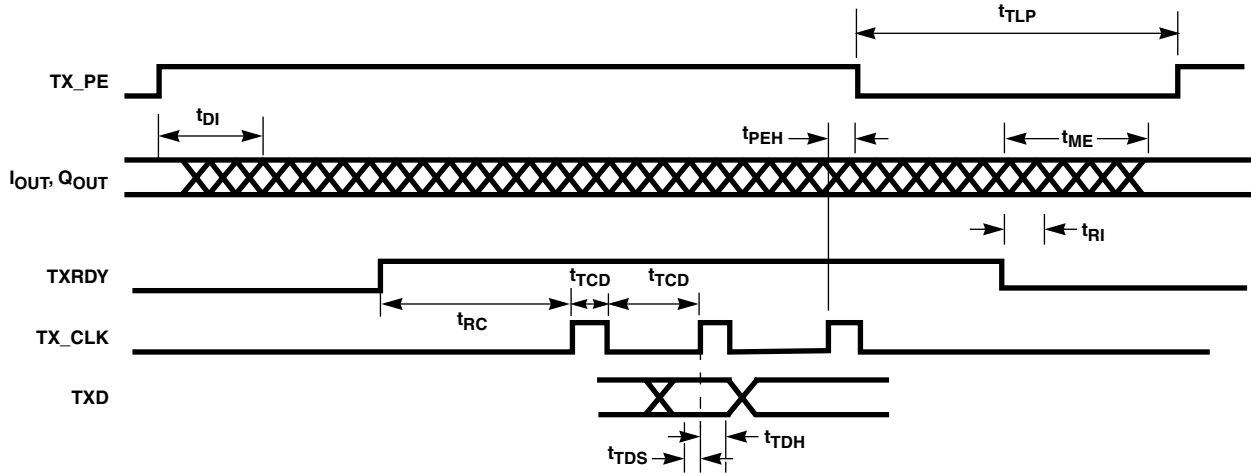
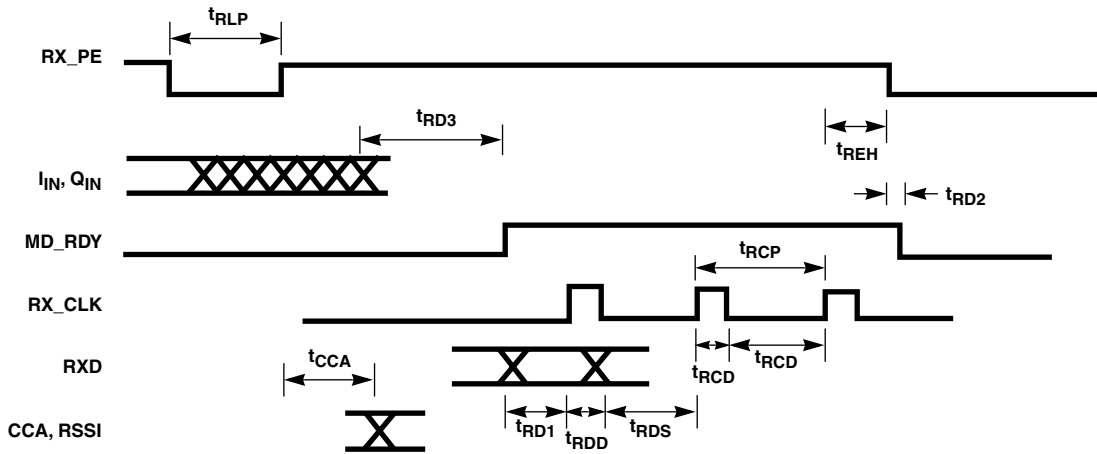

FIGURE 21. TX PORT SIGNAL TIMING



NOTE: RXD, MD\_RDY is output two MCLK after RXCLK rising to provide hold time. RSSI Output on TEST (5:0).

FIGURE 22. RX PORT SIGNAL TIMING

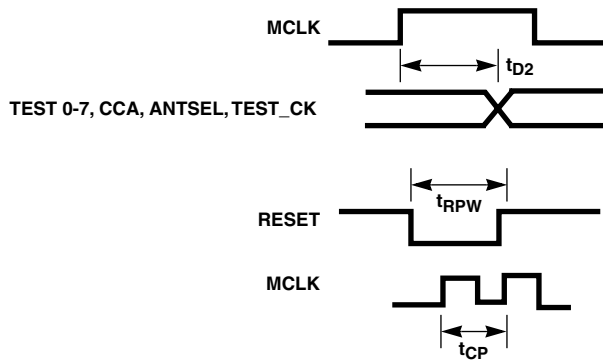
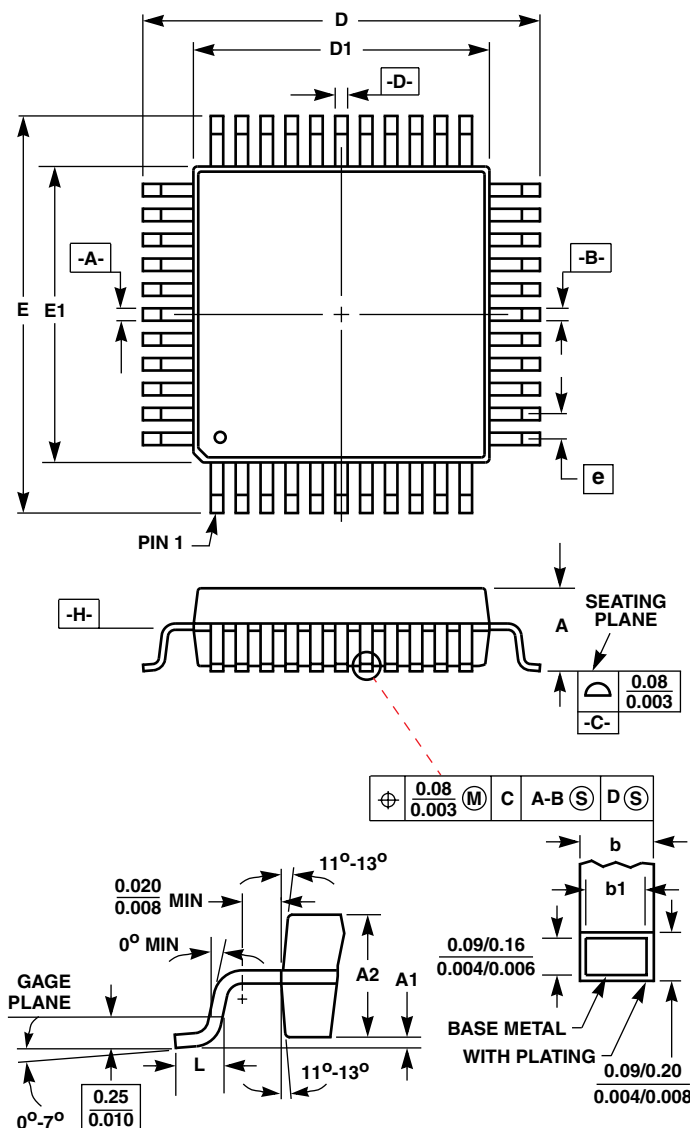

FIGURE 23. MISCELLANEOUS SIGNAL TIMING



Thin Plastic Quad Flatpack Packages (TQFP)



**Q64.10x10 (JEDEC MS-026ACD ISSUE B)**  
**64 LEAD THIN PLASTIC QUAD FLATPACK PACKAGE**

SYMBOL	INCHES		MILLIMETERS		NOTES
	MIN	MAX	MIN	MAX	
A	-	0.047	-	1.20	-
A1	0.002	0.005	0.05	0.15	-
A2	0.038	0.041	0.95	1.05	-
b	0.007	0.010	0.17	0.27	6
b1	0.007	0.009	0.17	0.23	-
D	0.468	0.476	11.90	12.10	3
D1	0.390	0.397	9.9	10.10	4, 5
E	0.468	0.476	11.9	12.10	3
E1	0.390	0.397	9.9	10.10	4, 5
L	0.018	0.029	0.45	0.75	-
N	64		64		7
e	0.020 BSC		0.50 BSC		-

Rev. 0 7/98

NOTES:

1. Controlling dimension: MILLIMETER. Converted inch dimensions are not necessarily exact.
2. All dimensions and tolerances per ANSI Y14.5M-1982.
3. Dimensions D and E to be determined at seating plane -C-.
4. Dimensions D1 and E1 to be determined at datum plane -H-.
5. Dimensions D1 and E1 do not include mold protrusion. Allowable protrusion is 0.25mm (0.010 inch) per side.
6. Dimension b does not include dambar protrusion. Allowable dambar protrusion shall not cause the lead width to exceed the maximum b dimension by more than 0.08mm (0.003 inch).
7. "N" is the number of terminal positions.

All Intersil U.S. products are manufactured, assembled and tested utilizing ISO9000 quality systems. Intersil Corporation's quality certifications can be viewed at [www.intersil.com/design/quality](http://www.intersil.com/design/quality)

*Intersil products are sold by description only. Intersil Corporation reserves the right to make changes in circuit design, software and/or specifications at any time without notice. Accordingly, the reader is cautioned to verify that data sheets are current before placing orders. Information furnished by Intersil is believed to be accurate and reliable. However, no responsibility is assumed by Intersil or its subsidiaries for its use; nor for any infringements of patents or other rights of third parties which may result from its use. No license is granted by implication or otherwise under any patent or patent rights of Intersil or its subsidiaries.*

For information regarding Intersil Corporation and its products, see [www.intersil.com](http://www.intersil.com)

**Sales Office Headquarters**

**NORTH AMERICA**  
 Intersil Corporation  
 7585 Irvine Center Drive  
 Suite 100  
 Irvine, CA 92618  
 TEL: (949) 341-7000  
 FAX: (949) 341-7123

Intersil Corporation  
 2401 Palm Bay Rd.  
 Palm Bay, FL 32905  
 TEL: (321) 724-7000  
 FAX: (321) 724-7946

**EUROPE**  
 Intersil Europe Sarl  
 Ave. William Graisse, 3  
 1006 Lausanne  
 Switzerland  
 TEL: +41 21 6140560  
 FAX: +41 21 6140579

**ASIA**  
 Intersil Corporation  
 Unit 1804 18/F Guangdong Water Building  
 83 Austin Road  
 TST, Kowloon Hong Kong  
 TEL: +852 2723 6339  
 FAX: +852 2730 1433