

Silicon Variable Capacitance Diode

BB 112

- For AM tuning applications
- Specified tuning range
1 ... 8.0 V

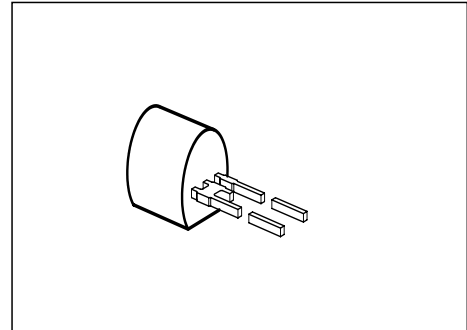

Type	Marking	Ordering Code	Pin Configuration	Package ¹⁾
BB 112	–	Q62702-B240		TO-92

Maximum Ratings

Parameter	Symbol	Values	Unit
Reverse voltage	V_R	12	V
Forward current, $T_A \leq 60 \text{ }^\circ\text{C}$	I_F	50	mA
Operating temperature range	T_{op}	– 55 ... + 85	$^\circ\text{C}$

¹⁾ For detailed information see chapter Package Outlines.

Electrical Characteristics

at $T_A = 25\text{ °C}$, unless otherwise specified.

Parameter	Symbol	Values			Unit
		min.	typ.	max.	
Reverse current $V_R = 10\text{ V}$ $V_R = 10\text{ V}, T_A = 60\text{ °C}$	I_R	– –	– –	50 200	nA
Diode capacitance, $f = 1\text{ MHz}$ $V_R = 1\text{ V}$ $V_R = 8\text{ V}$	C_T	440 17.5	470 –	520 34	pF
Capacitance ratio $V_R = 1\text{ V}, 8\text{ V}$	$\frac{C_{T1}}{C_{T8}}$	15	–	–	–
Series resistance $V_R = 1\text{ V}, f = 0.5\text{ MHz}$	r_s	–	1.4	–	Ω
Q factor $V_R = 1\text{ V}, f = 0.5\text{ MHz}$	Q	–	480	–	–
Temperature coefficient of diode capacitance $V_R = 1\text{ V}, f = 1\text{ MHz}$	TC_C	–	500	–	ppm/K
Capacitance matching $V_R = 1 \dots 8\text{ V}$	$\frac{\Delta C_T}{\bar{C}}$	–	–	3	%

Diode capacitance $C_T = f(V_R)$

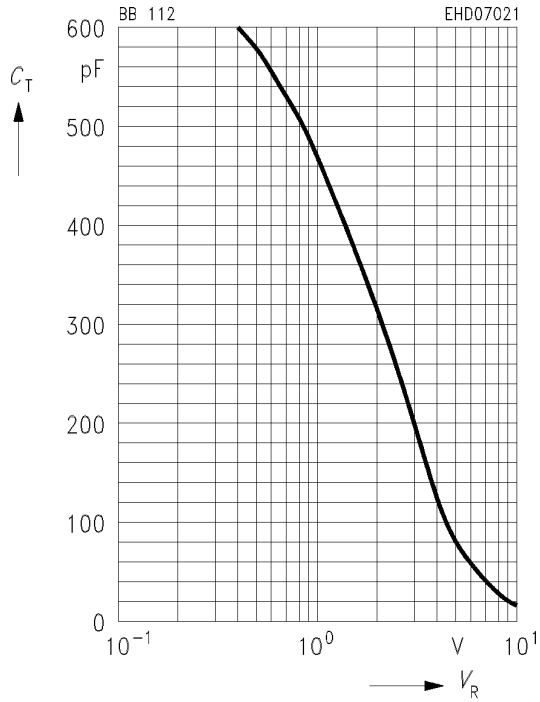

Capacitance ratio $C_T/C_{Tref} = f(V_R)$

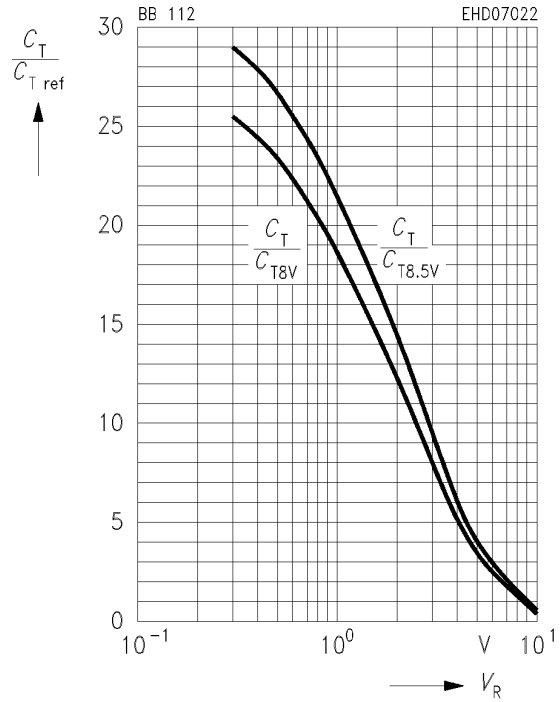

Capacitance ratio $C_T/C_{T1V} = f(V_R)$

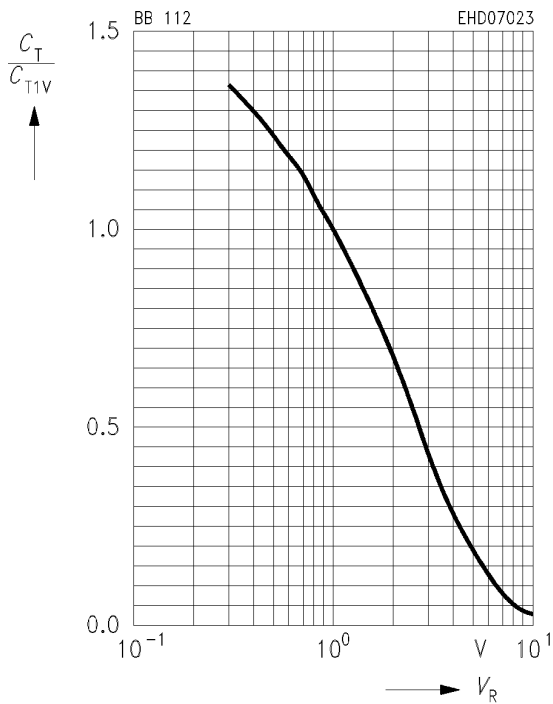

Temperature coefficient of junction capacitance $TC_C = f(V_R)$

