

Stepping motor driver

BA6845FS

The BA6845FS is a stepping motor driver with a maximum output current of 1.0A. The logic input allows three output modes : forward, reverse, and power save. The IC has a low output saturation voltage and is capable of driving motors at low supply voltage.

●Applications

Stepping motors for floppy disk drives

●Features

- 1) Low output saturation voltage.
- 2) Power save circuit.
- 3) Thermal shutdown circuit.

●Absolute maximum ratings (Ta = 25°C)

Parameter	Symbol	Limits	Unit
Applied voltage	V _{CC}	12	V
Power dissipation	P _d	800* ¹	mW
Operating temperature	T _{opr}	-25~+75	°C
Storage temperature	T _{stg}	-55~+150	°C
Allowable output current	I _{oMax.}	1000* ²	mA

*1 When mounted on a glass epoxy PCB (90 X 50 X 1.6 mm) board.

Reduced by 6.4 mW for each increase in Ta of 1°C over 25°C.

*2 Should not exceed P_d- or ASO-value.

●Recommended operating conditions (Ta = 25°C)

Parameter	Symbol	Limits	Unit
Power supply voltage	V _{CC}	2.7~9.0	V

●Block diagram

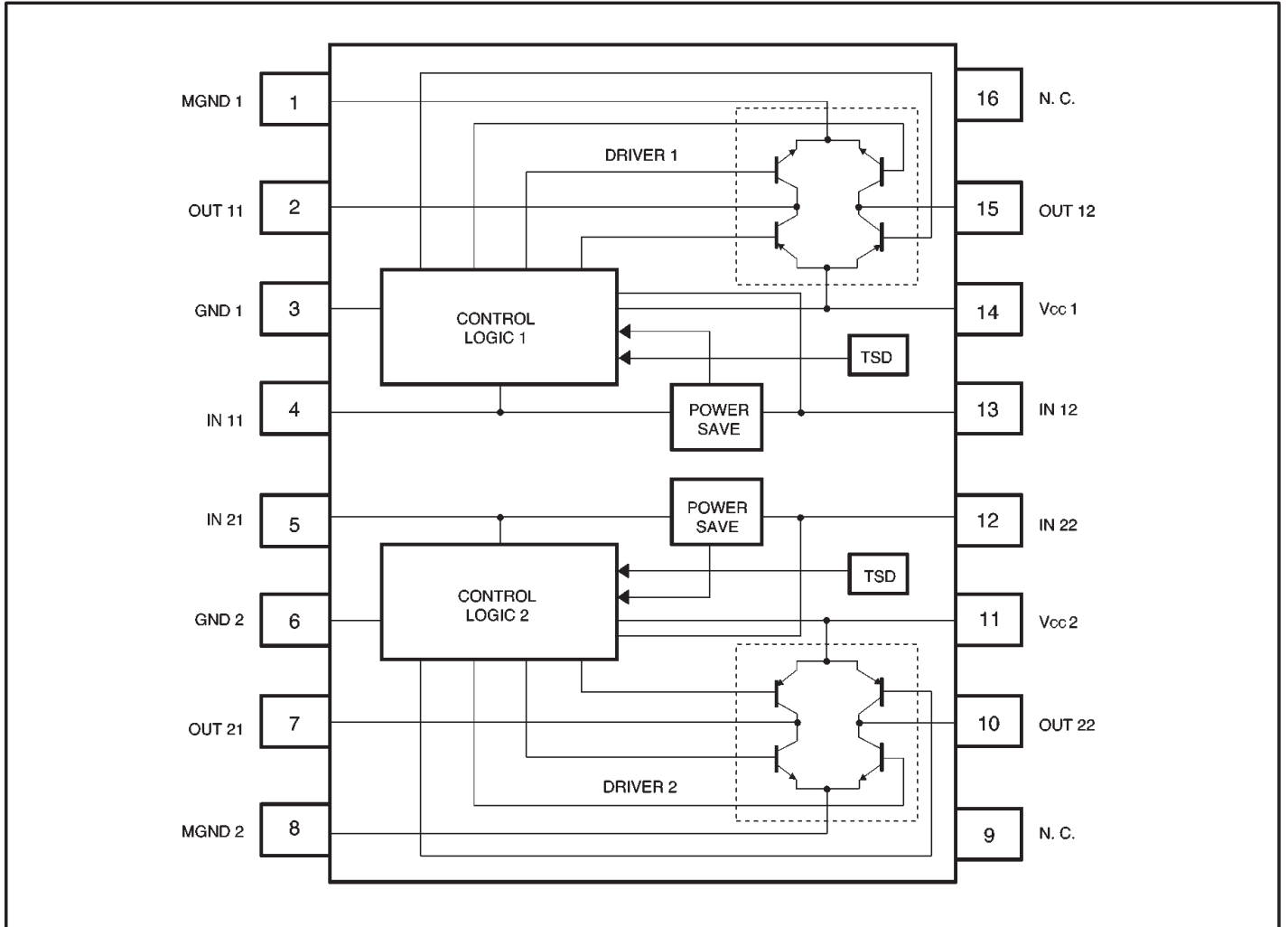

● Pin descriptions

Pin No.	Pin name	Function
1	MGND 1	Motor ground
2	OUT 11	Motor output
3	GND 1	Ground
4	IN 11	Logic input
5	IN 21	Logic input
6	GND 2	Ground
7	OUT 21	Motor output
8	MGND 2	Motor ground
9	N. C.	N. C.
10	OUT 22	Motor output
11	V _{CC} 2	Power supply
12	IN 22	Logic input
13	IN 12	Logic input
14	V _{CC} 1	Power supply
15	OUT 12	Motor output
16	N. C.	N. C.

● Input / output circuits (all resistances are typical values)

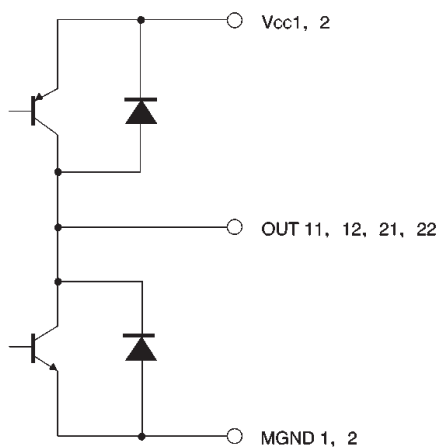
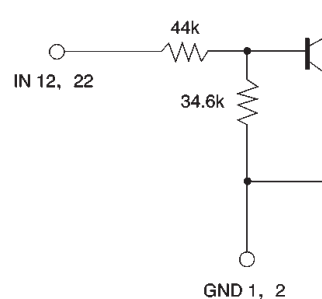
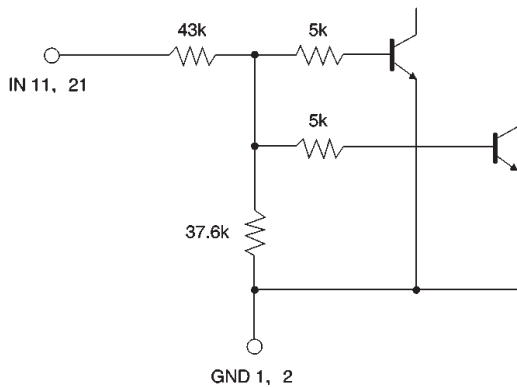

●Electrical characteristics (unless otherwise noted, Ta = 25°C, Vcc = 5V)

Parameter	Symbol	Min.	Typ.	Max.	Unit	Conditions
Supply current 1	I _{cc1}	—	55	80	mA	IN12=IN22=5V
Supply current 2	I _{cc2}	—	—	10	μA	IN12=IN22=0V
Output saturation voltage	V _{sat}	—	0.5	0.7	V	I _{out} =400mA, sum of the high-and low-side voltage
Input threshold voltage	V _{IN}	1.0	1.5	2.1	V	
Input current	I _{IN}	—	100	150	μA	IN11, 12, 21, 22=5V

◎Not designed for radiation resistance.

●Truth table

IN11 / 21	IN12 / 22	OUT11 / 21	OUT12 / 22	Mode
L	H	H	L	Forward
H	H	L	H	Reverse
L	L	OPEN	OPEN	Stop
H	L	OPEN	OPEN	Stop

●Application example

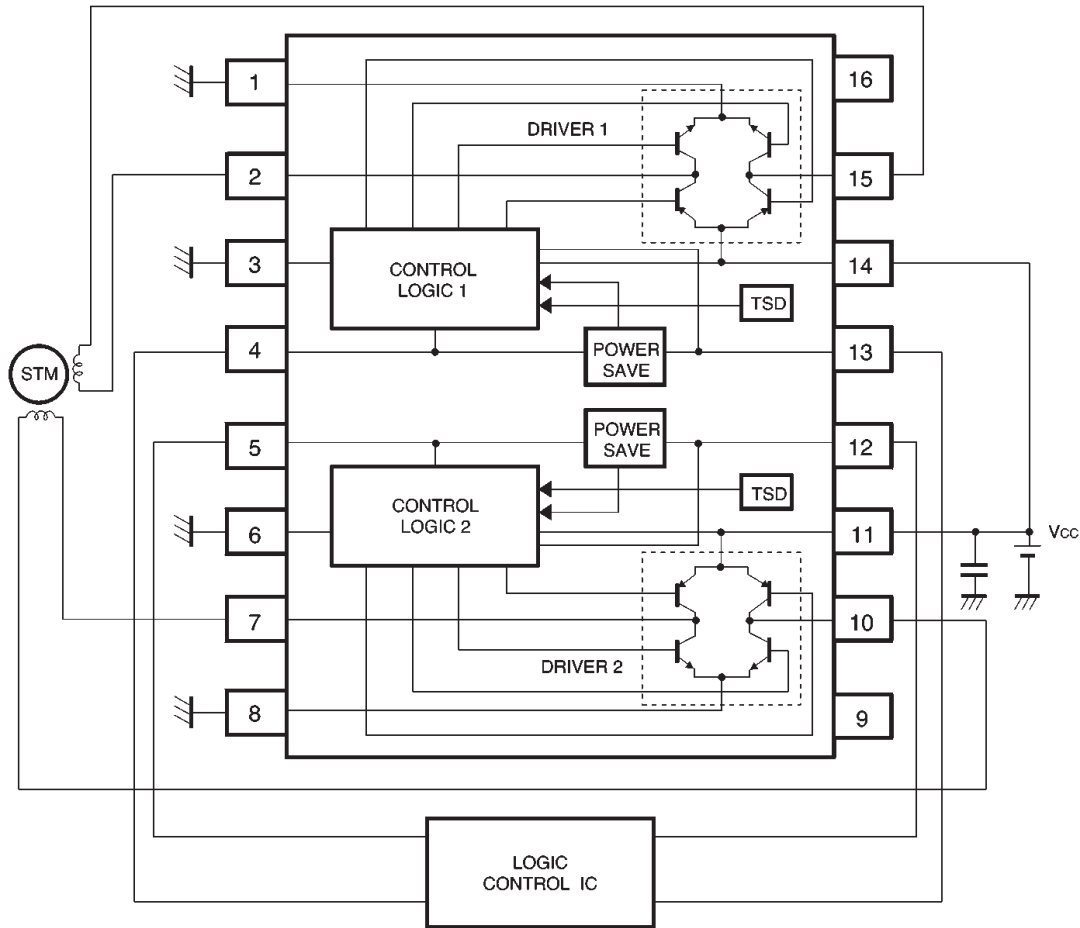

Fig.1

●Operation notes

(1) Control logic pins

Do not apply voltage to control logic pins (pins 4, 5, 12, and 13) when the V_{CC} voltage is not applied to the IC. The voltage of each pin should be less than V_{CC} , if applied, and should be more than the ground voltage.

(2) PCB arrangement

When changing the rotational direction of a motor, a large current of up to a few hundred milliamperes can flow between the motor power supply (pins 11 and 14) and MGND (pins 1 and 8). Depending on the application, this large output current may flow back to input pins, resulting in output oscillation or other malfunctions. Make sure that your design does not allow a common impedance between the large current output lines and the input section. Suppress the power supply impedance to low levels, otherwise output oscillation may occur.

(3) Package power dissipation

The power dissipated by the IC varies widely with the supply voltage and the output current. Give full consideration to the package power dissipation rating when setting the supply voltage and the output current.

(4) Ground pins

Pins 1, 3, 6, and 8 should have the lowest potential (ground potential) in the IC.

(5) Thermal shutdown circuit

This circuit shuts down all the driver outputs when the chip junction temperature is increased to about 175°C (typical). The thermal shutdown circuit is deactivated when the temperature drops to about 20°C (typical).

(6) Input pins (pins 4, 5, 12, and 13)

These pins have characteristics negatively correlated to temperature. Give full consideration to the temperature effect when using the IC.

●Electrical characteristic curves

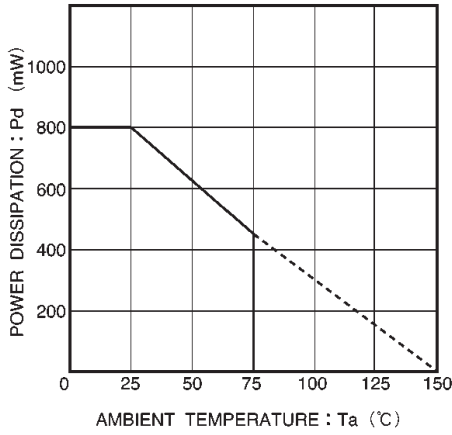

Fig.2 Power dissipation curve

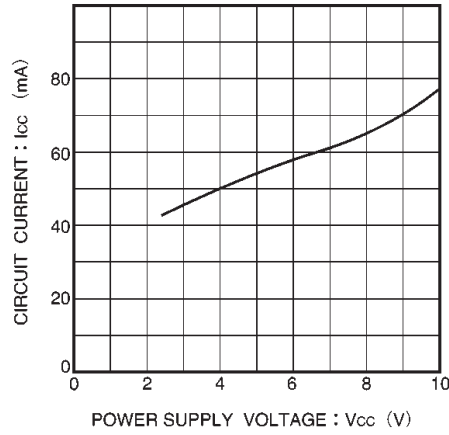

Fig.3 Circuit current vs. power supply voltage

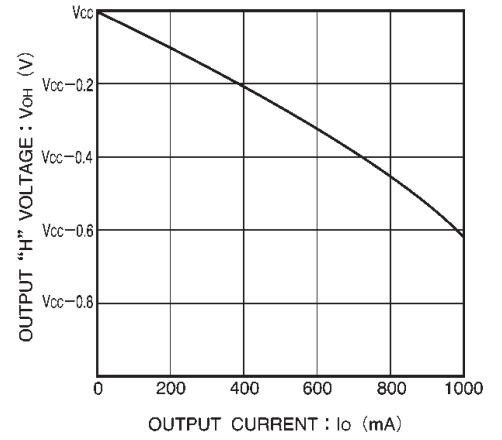

Fig.4 HIGH level output voltage vs. output current

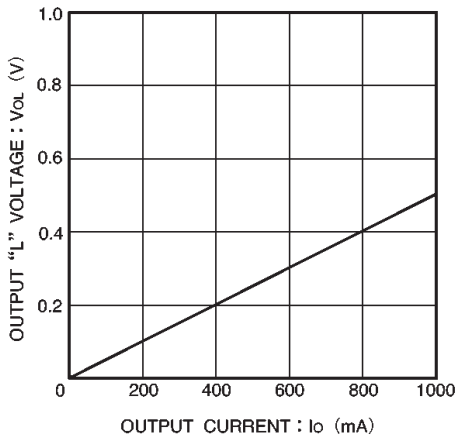

Fig.5 LOW level output voltage vs. output current

●External dimensions (Units: mm)

