

**GENERAL DESCRIPTION**

The L432 is a three-terminal adjustable shunt regulator utilizing an accurate 1.24V band gap reference. The output voltage can be set to any value between 1.24V ( $V_{REF}$ ) to 18V with two external resistors as shown in the typical application circuit. The device exhibit a wide operating current range of 0.2 to 100 mA with a typical dynamic impedance of  $0.25\ \Omega$ . Active output circuitry provides a very sharp turn-on characteristic, making the L432 excellent replacements for low-voltage zener diodes in many applications, including on-board regulation and adjustable power supplies.

When used with an opto-coupler, the L432 is ideal voltage reference in isolated feedback circuits for 3.3V switching-mode power supplies. The L432 shunt regulator is available in two voltage tolerances (0.5% & 1.0%) and three package options (TO-92, SOT-23-3 and SO-8).

**FEATURES**

- Internal amplifier with 100 mA capability
- Programmable output voltage to 18V
- $0.25\ \Omega$  typical output impedance
- Pin to pin compatible with TLV431A, TS431, SC431L & AS432
- Trimmed bandgap design 0.5% & 1.0% with three package options
- Low output noise

**APPLICATIONS**

- Linear regulator controller
- Precision voltage reference
- Switching power supplies
- Battery operating equipment
- Instrumentation
- PCs, Computer disk drives

**SYMBOL & BLOCK DIAGRAM**

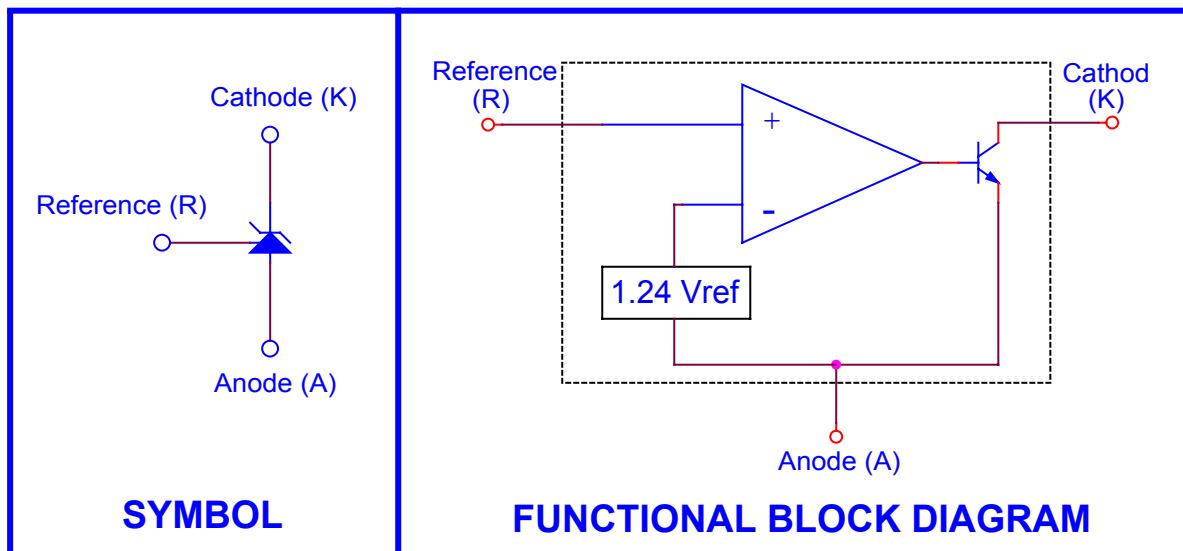

**ABSOLUTE MAXIMUM RATINGS**

PARAMETER	VALUE
Cathode-Anode Reverse Breakdown Voltage - $V_{KA}$	20V
Anode-Cathode Forward Current - $I_{AK}$	1 A
Operating Cathode Current - $I_{KA}$	100 mA
Reference Input Current - $I_{REF}$	1 mA
Storage Temperature Range - $T_{STG}$	-65 to +150 °C
Junction Temperature - $T_J$	150 °C
Lead Temperature (Soldering, 10 Seconds) - $T_L$	300 °C
Continuous Power at 25 °C - $P_D$	
TO-92	700 mW
SOIC-8	650 mW
SOT-23	200 mW

**RECOMMENDED CONDITIONS**

Parameter	Rating
Cathode Voltage ( $V_{KA}$ )	$V_{REF}$ to 18V
Cathode Current ( $I_K$ )	10 mA

**TYPICAL THERMAL RESISTANCES**

Package	$\theta_{JA}$	$\theta_{JC}$	Typ. De-rating
TO-92	160 °C/W	80 °C/W	6.3 mW/°C
SOIC-8	175 °C/W	45 °C/W	5.7 mW/°C
SOT-23	575 °C/W	150 °C/W	1.7 mW/°C

**ELECTRICAL SPECIFICATIONS**

(Ambient temperature must be derated base on power dissipation and package thermal characteristics. The conditions are:  $V_{KA} = V_{REF}$  and  $I_K = 10$  mA unless otherwise stated)

PARAMETER	TEST CONDITIONS	MIN	TYP	MAX	UNITS	TEST CIRCUIT
Output Voltage - $V_{REF}$	$T_A = 25$ °C, L432 (0.5%)	1.234	1.240	1.246	V	1
	$T_A = 25$ °C, L432 (1%)	1.228	1.240	1.252		
Line Regulation - $\Delta V_{REF}$	$V_{KA} = V_{REF}$ to 15V		28	50	mV	2
Load Regulation - $\Delta V_{REF}$	$I_K = 1$ to 100 mA		3.9	6	mV	1
Temperature Deviation - $\Delta V_{REF}$	$0 < T_J < 105$ °C		5	12	mV	1
Reference Input Current - $I_{REF}$			2.3	6	μA	1
Reference Input Current Temperature Coefficient - $\Delta I_{REF}$	$0 < T_J < 105$ °C		0.14	0.6	μA	1
Minimum Cathode Current for Regulation - $I_{K(MIN)}$			0.2	1	mA	1
Off State Leakage - $I_{K(MIN)}$	$V_{REF} = 0V, V_{KA} = 15V$		40	500	nA	3
Dynamic impedance	$V_{KA} = V_{ref}, f \leq 1kHz$ $I_K = 0.1$ mA to 100 mA		0.25	0.4	Ω	1

**TEST CIRCUITS**

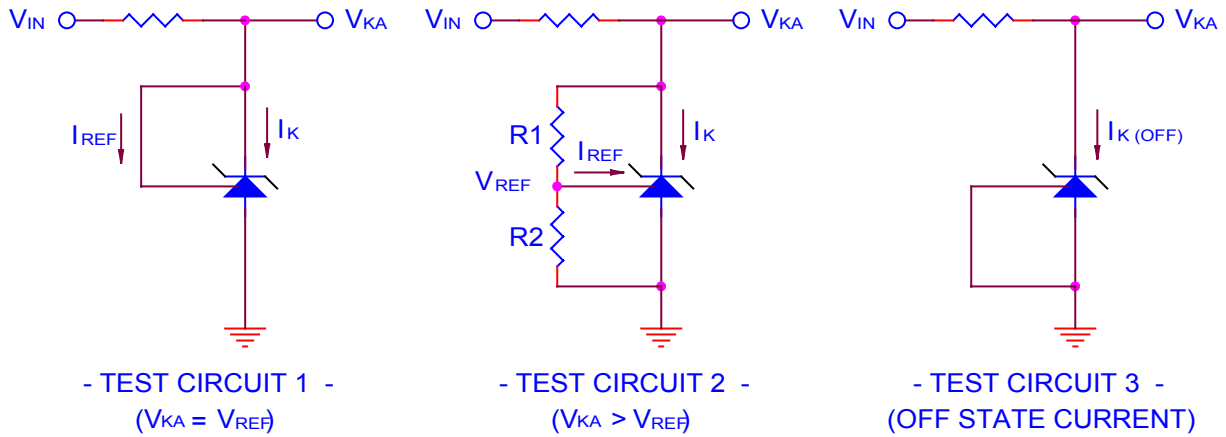

**Applications Information – Stability**

**Selection of load capacitance when using L432 as a shunt regulator**

When the L432 is used as a shunt regulator, two options for selection of CL are recommended for optimal stability:

1. No load capacitance across the device, decouple at the load.
2. Large capacitance across the device, optional decoupling at the load.

The reason for this is that L432 exhibits instability with capacitances in the range of 1nF to 1uF (approx.) at light cathode currents (up to 3mA typical). The device is less stable the lower the cathode voltage has been set for. Therefore while the device will be perfectly stable operating at a cathode current of 10mA with a 0.1uF capacitor across it, it will oscillate transiently during start-up as the cathode current passes through the instability region. Selecting a very low

(or preferably, no)capacitance, or alternatively a high capacitance (such as 10uF) will avoid this issue altogether. Since the user will probably wish to have local decoupling at the load anyway, the most cost effective method is to use no capacitance at all directly across the device. PCB trace/via resistance and inductance prevent the local load decoupling from causing the oscillation during the transient start-up phase. Note : if the L432 is located right at the load, so the load decoupling capacitor is directly across it, then this capacitor will have to be  $\leq 100\text{pF}$  or  $\geq 1\mu\text{F}$ .

Small-Signal Gain and Phase Shift VS. Frequency

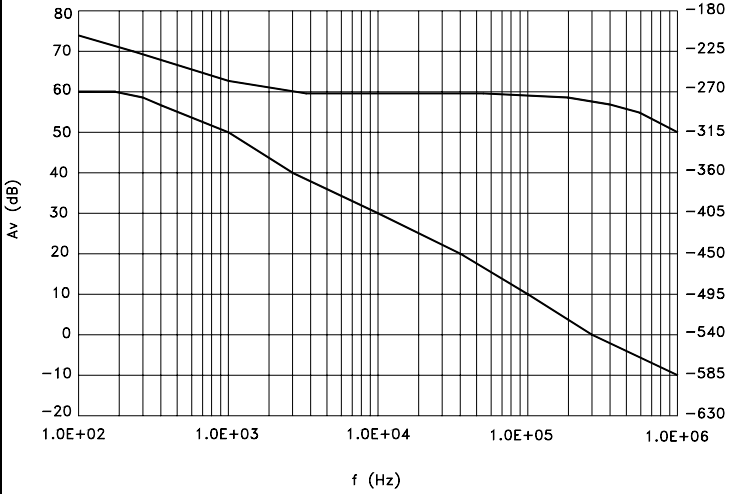

Test Circuit for Small Signal Gain and Phase

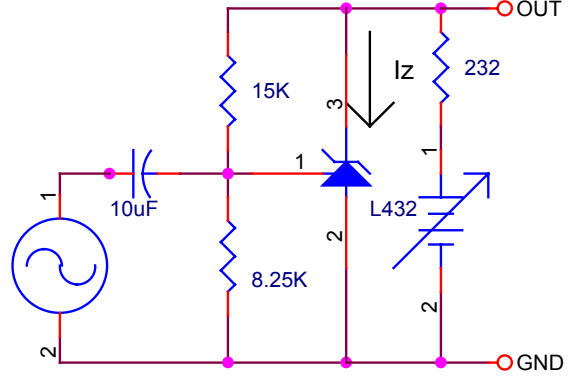

Stability Boundary Condition For Shunt Regulation VS. Cathode Current and Load Capacitance

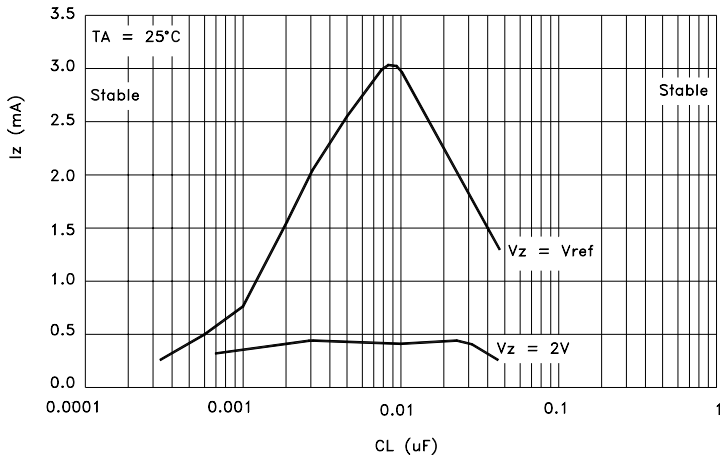

Test Circuit for Stability

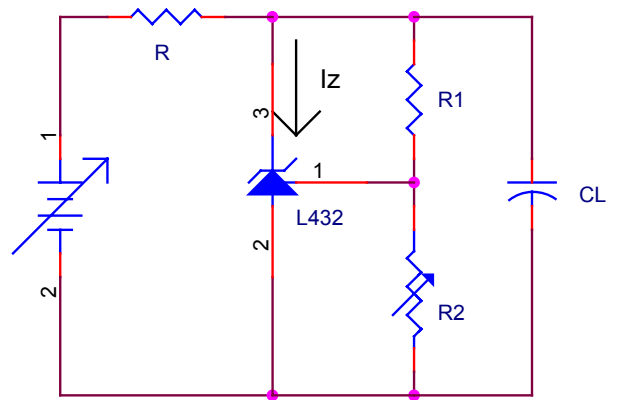

Cathode Current VS. Cathode Voltage

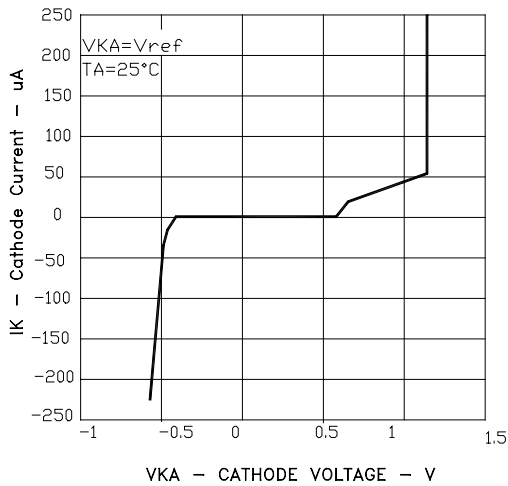

Cathode Current VS. Cathode Voltage

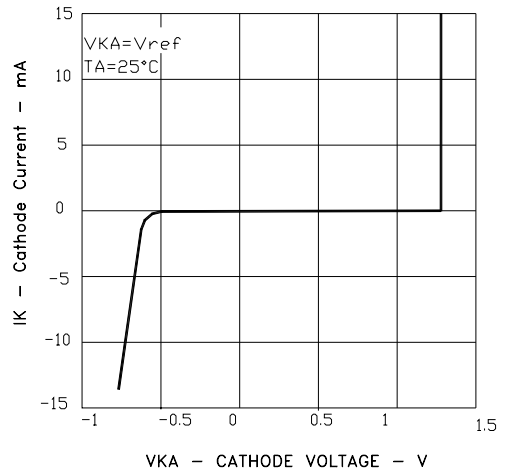

Reference Voltage  
VS. Junction Temperature

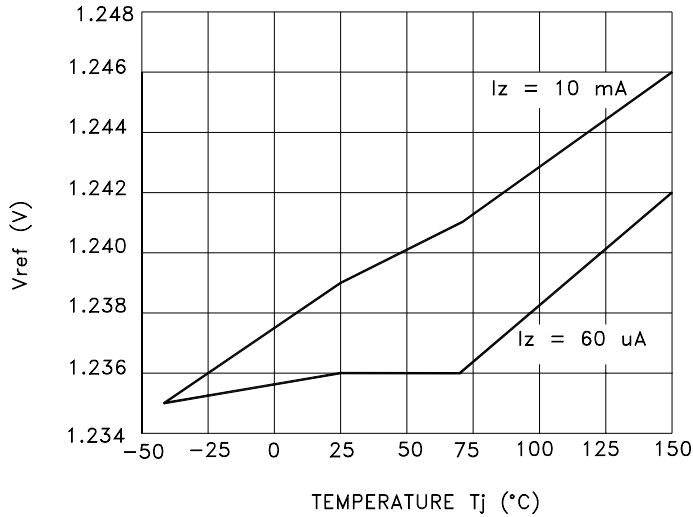

Reference Impedance  
VS. Frequency

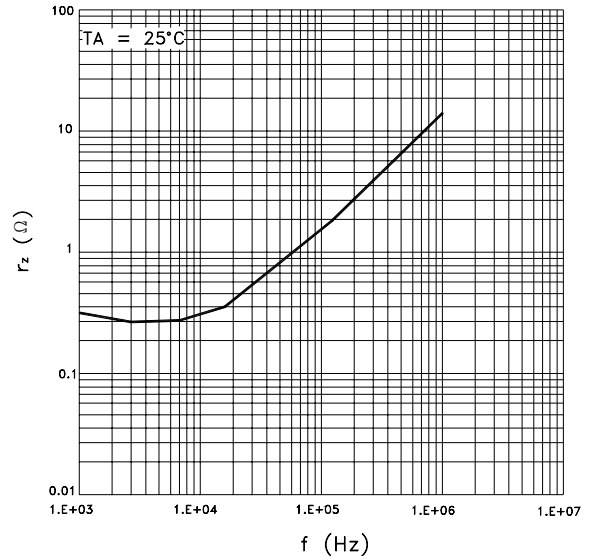

Ratio of Delta Reference Voltage to Delta Cathode Voltage  
VS. Junction Temperature

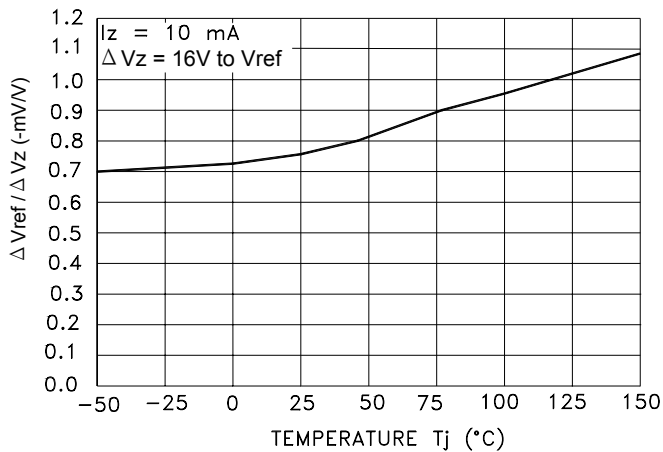

Reference Input Current  
VS. Junction Temperature

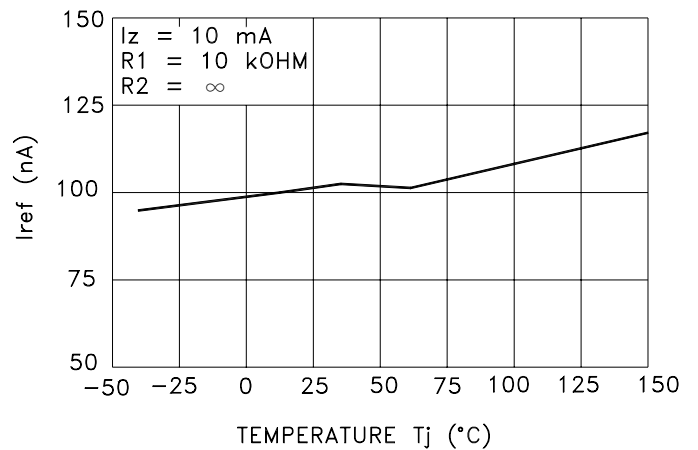

Off-State Cathode Current  
VS. Junction Temperature

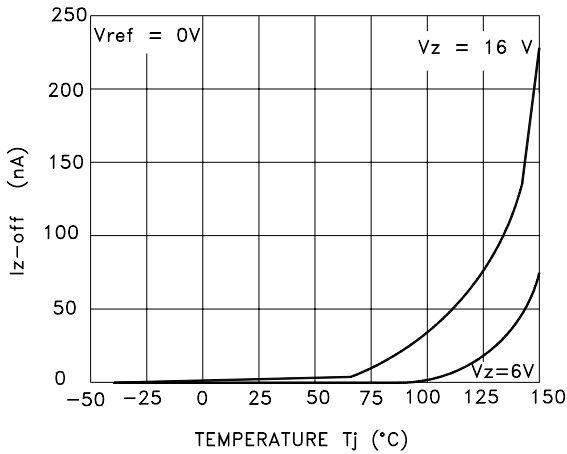

Reference Impedance  
VS. Junction Temperature

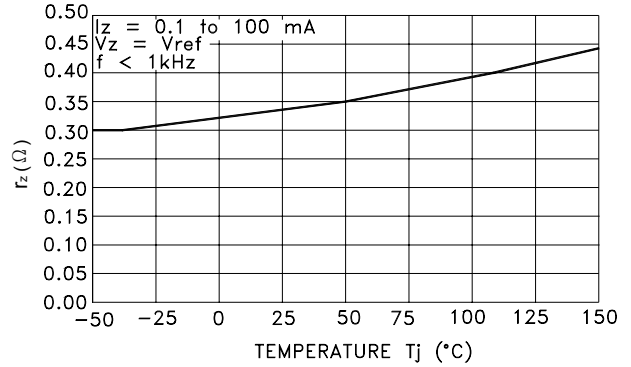

**PIN CONFIGURATIONS**

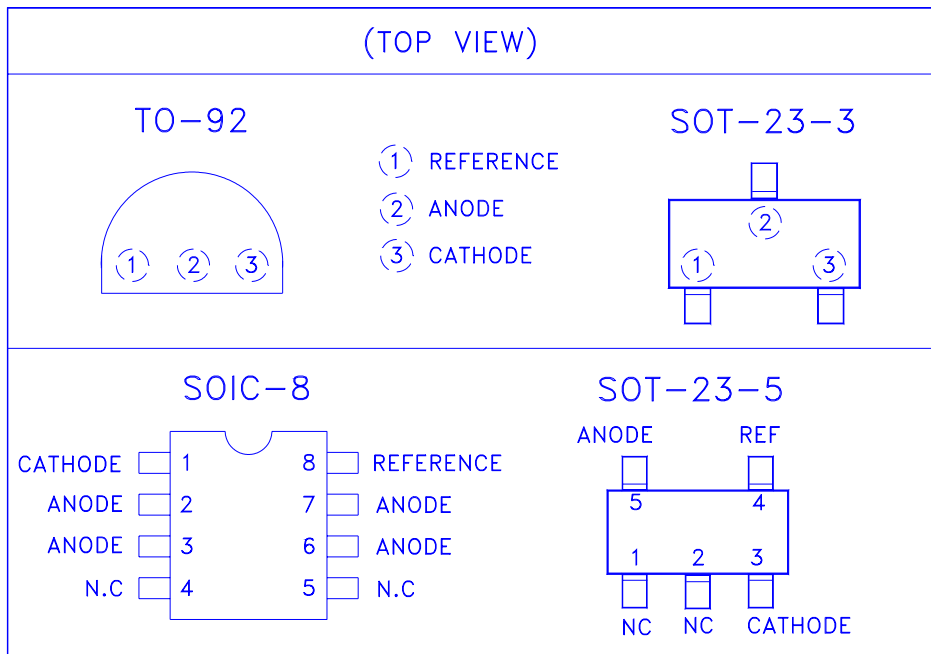

**DEVICE SELECTION GUIDE**

Device	L432NB	L432M3B	L432VB	L432M5B
Package	TO-92	SOT-23-3	SOIC-8	SOT-23-5
Marking	L432NA	2M3A	L432V	2M5A
Tolerance	1%	1%	1%	1%

**APPLICATION CIRCUIT**

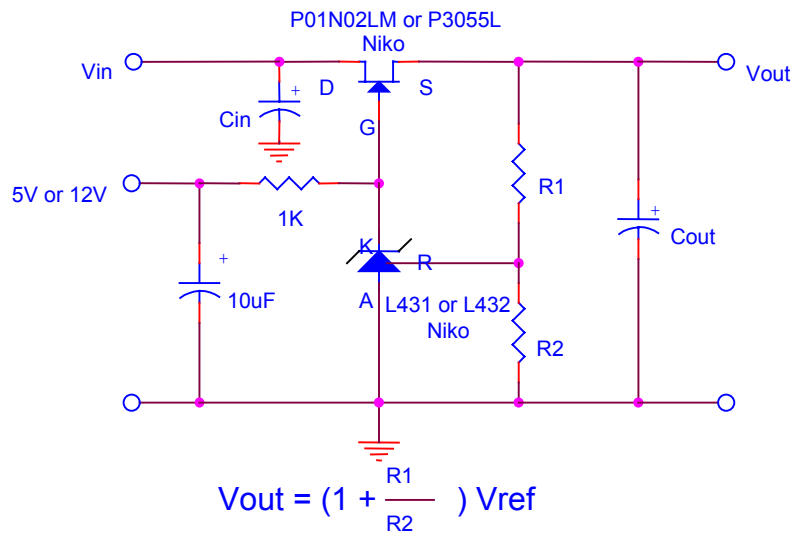

**TO-92 MECHANICAL DATA**

Dimension	mm			Dimension	mm		
	Min.	Typ.	Max.		Min.	Typ.	Max.
A	4.445		5.207	H	2.413	2.540	2.667
B	4.318		5.334	I	0.356		0.533
C	12.7		15.5	J			
D	0.356		0.533	K			
E	1.143	1.27	1.397	L			
F	3.175		4.191	M			
G	0.762		1.270	N			

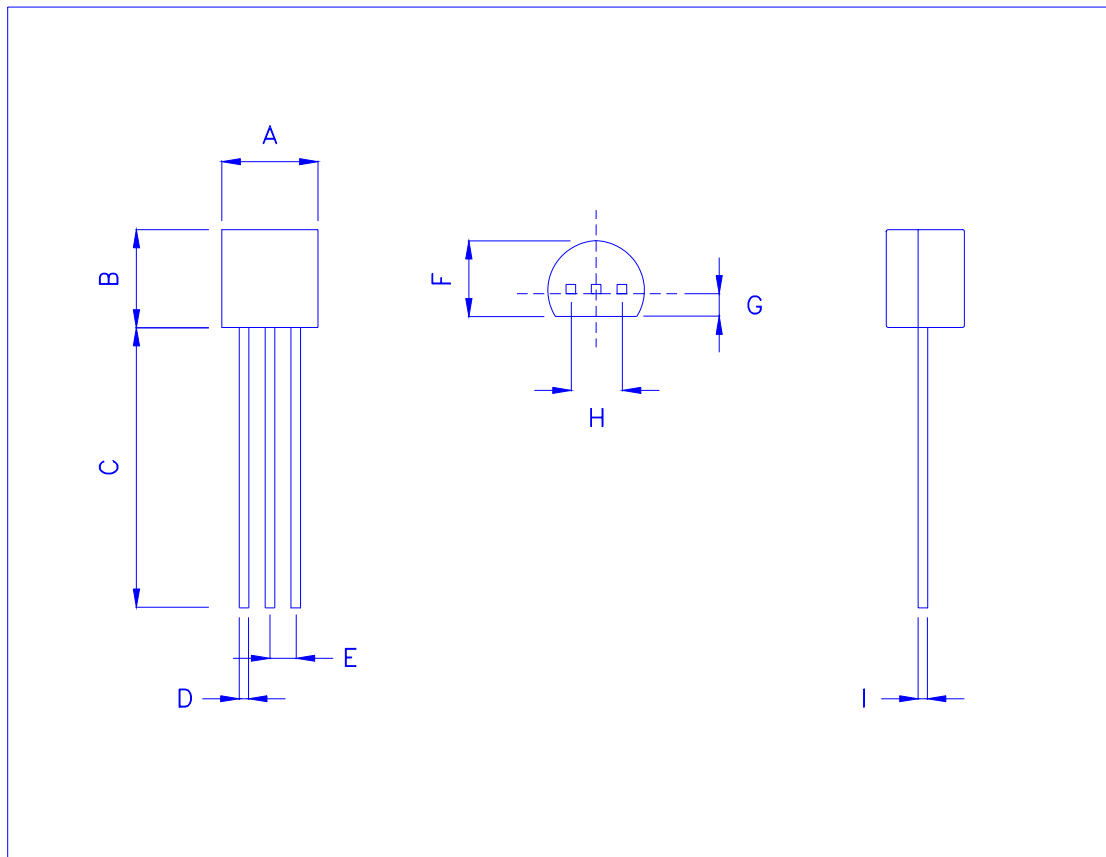



**SOT-23 (M3) MECHANICAL DATA**

Dimension	mm			Dimension	mm		
	Min.	Typ.	Max.		Min.	Typ.	Max.
A		0.95		H	0.10	0.15	0.25
B	2.60	2.80	3.00	I	0.37		
C	1.40	1.60	1.80	J			
D	2.70	2.90	3.10	K			
E	1.00	1.10	1.30	L			
F	0.00		0.10	M			
G	0.35	0.4	0.5	N			

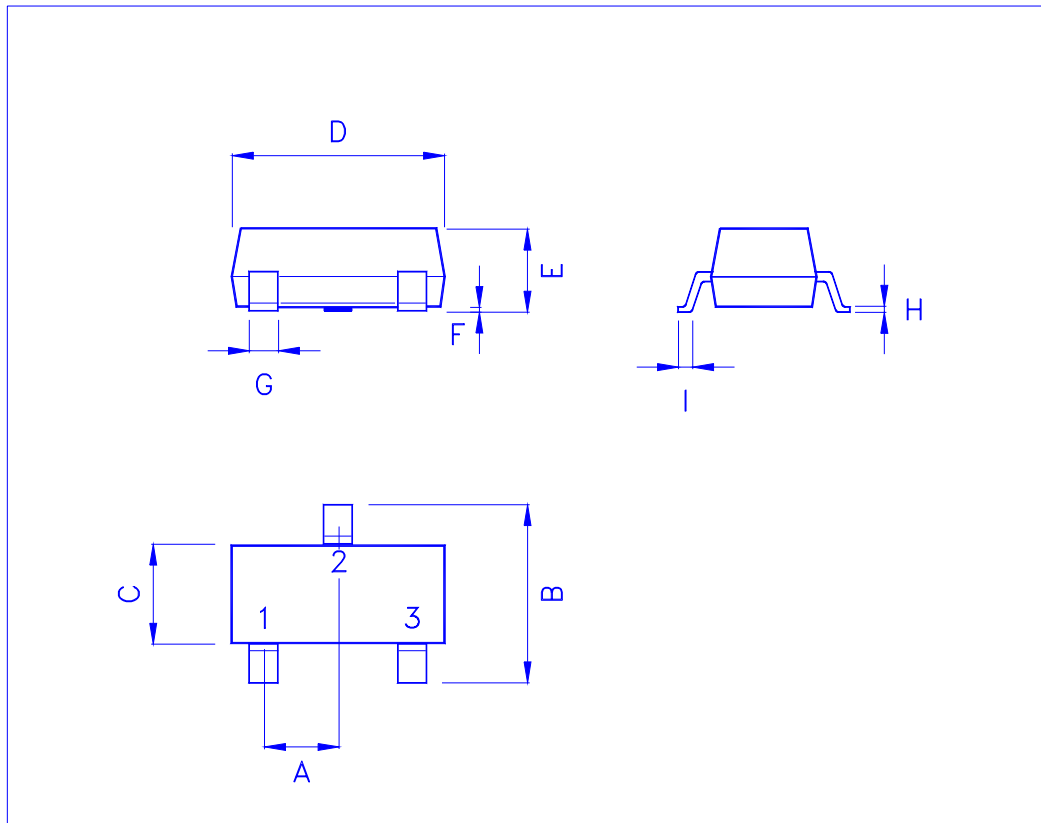

**SOIC-8 (D) MECHANICAL DATA**

Dimension	mm			Dimension	mm		
	Min.	Typ.	Max.		Min.	Typ.	Max.
A	4.8		5.0	H	0.4		1.27
B	3.8		4.0	I	0.18		0.25
C	5.8		6.2	J		0.22	
D	0.35		0.48	K	0°		8°
E		1.27		L			
F			1.65	M			
G	0.1		0.25	N			

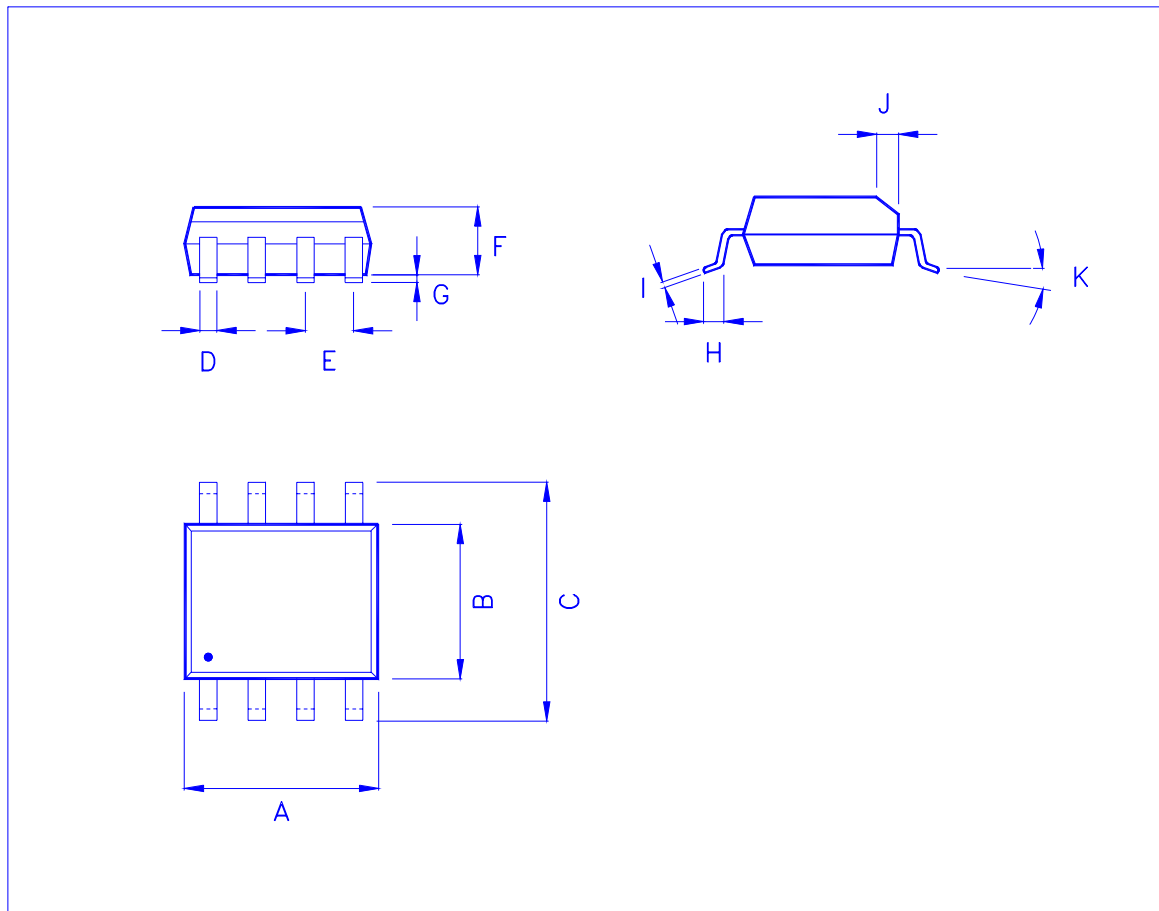

**SOT-23 (M5) MECHANICAL DATA**

Dimension	mm			Dimension	mm		
	Min.	Typ.	Max.		Min.	Typ.	Max.
A	1.0	1.10	1.30	e		1.90(TYP)	
A1	0.00		0.10	H	2.60	2.80	3.00
A2	0.70	0.80	0.90	L	0.37		
b	0.35	0.40	0.50				
C	0.10	0.15	0.25				
D	2.70	2.90	3.10				
E	1.40	1.60	1.80				

