

HEX SCHMITT INVERTER

- HIGH SPEED: $t_{PD} = 4.5ns$ (TYP.) at $V_{CC} = 5V$
- LOW POWER DISSIPATION:
 $I_{CC} = 4\mu A$ (MAX.) at $T_A=25^\circ C$
- 50Ω TRANSMISSION LINE DRIVING CAPABILITY
- SYMMETRICAL OUTPUT IMPEDANCE:
 $|I_{OH}| = I_{OL} = 24mA$ (MIN)
- BALANCED PROPAGATION DELAYS:
 $t_{PLH} \cong t_{PHL}$
- OPERATING VOLTAGE RANGE:
 V_{CC} (OPR) = 2V to 6V
- PIN AND FUNCTION COMPATIBLE WITH 74 SERIES 14
- IMPROVED LATCH-UP IMMUNITY

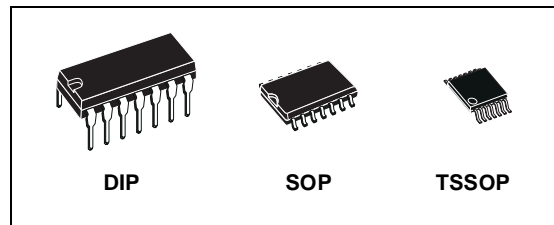

ORDER CODES

| PACKAGE | TUBE | T & R |
|---------|---------|-----------|
| DIP | 74AC14B | |
| SOP | 74AC14M | 74AC14MTR |
| TSSOP | | 74AC14TTR |

DESCRIPTION

The 74AC14 is an advanced high-speed CMOS HEX SCHMITT TRIGGER INVERTER fabricated with sub-micron silicon gate and double-layer metal wiring C²MOS technology. The internal circuit is composed of 3 stages including buffer output, which enables high noise immunity and stable output.

This together with its schmitt trigger function allows it to be used on line receivers with slow rise/fall input signals. All inputs and outputs are equipped with protection circuits against static discharge, giving them 2KV ESD immunity and transient excess voltage.

PIN CONNECTION AND IEC LOGIC SYMBOLS

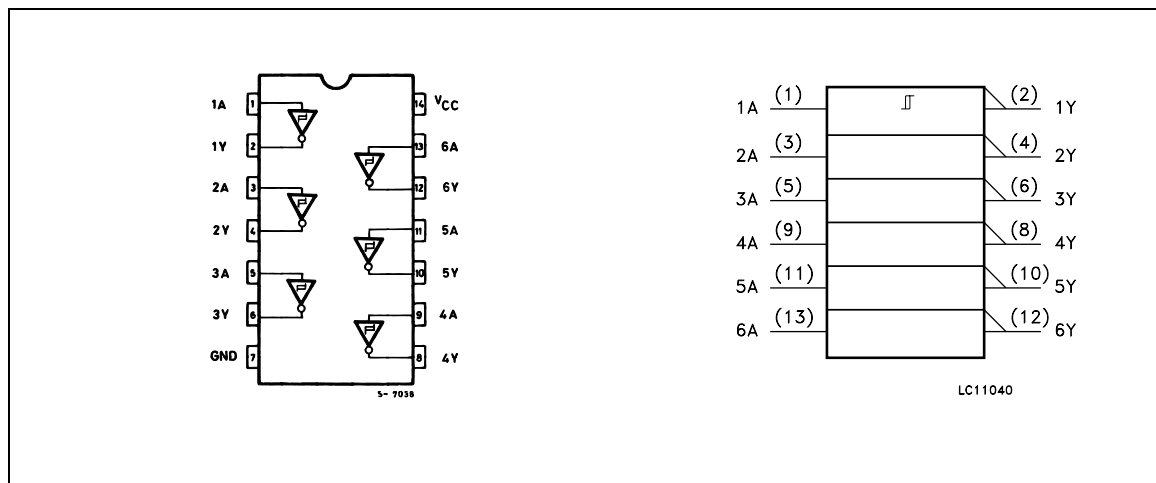

INPUT AND OUTPUT EQUIVALENT CIRCUIT

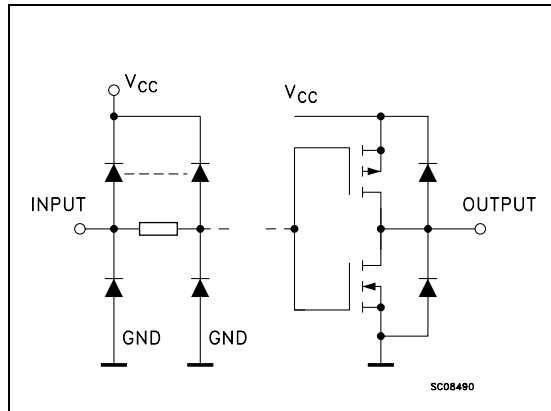

PIN DESCRIPTION

| PIN No | SYMBOL | NAME AND FUNCTION |
|--------------------|-----------------|-------------------------|
| 1, 3, 5, 9, 11, 13 | 1A to 6A | Data Inputs |
| 2, 4, 6, 8, 10, 12 | 1Y to 6Y | Data Outputs |
| 7 | GND | Ground (0V) |
| 14 | V _{CC} | Positive Supply Voltage |

TRUTH TABLE

| A | Y |
|---|---|
| L | H |
| H | L |

ABSOLUTE MAXIMUM RATINGS

| Symbol | Parameter | Value | Unit |
|-------------------------------------|--------------------------------------|-------------------------------|------|
| V _{CC} | Supply Voltage | -0.5 to +7 | V |
| V _I | DC Input Voltage | -0.5 to V _{CC} + 0.5 | V |
| V _O | DC Output Voltage | -0.5 to V _{CC} + 0.5 | V |
| I _{IK} | DC Input Diode Current | ± 20 | mA |
| I _{OK} | DC Output Diode Current | ± 20 | mA |
| I _O | DC Output Current | ± 50 | mA |
| I _{CC} or I _{GND} | DC V _{CC} or Ground Current | ± 300 | mA |
| T _{stg} | Storage Temperature | -65 to +150 | °C |
| T _L | Lead Temperature (10 sec) | 300 | °C |

Absolute Maximum Ratings are those values beyond which damage to the device may occur. Functional operation under these conditions is not implied.

RECOMMENDED OPERATING CONDITIONS

| Symbol | Parameter | Value | Unit |
|-----------------|-----------------------|----------------------|------|
| V _{CC} | Supply Voltage | 2 to 6 | V |
| V _I | Input Voltage | 0 to V _{CC} | V |
| V _O | Output Voltage | 0 to V _{CC} | V |
| T _{op} | Operating Temperature | -55 to 125 | °C |

DC SPECIFICATIONS

| Symbol | Parameter | Test Condition | | Value | | | | | | Unit | |
|------------------|------------------------------------|------------------------|---|-----------------------|-------|-------|-------------|------|--------------|------|------|
| | | V _{CC} (V) | | T _A = 25°C | | | -40 to 85°C | | -55 to 125°C | | |
| | | | | Min. | Typ. | Max. | Min. | Max. | Min. | | Max. |
| V _{t+} | High Level Input Voltage | 3.0 | T _A =Worst Case | 2.2 | | | 2.2 | | 2.2 | | V |
| | | 4.5 | | 3.2 | | | 3.2 | | 3.2 | | |
| | | 5.5 | | 3.9 | | | 3.9 | | 3.9 | | |
| V _{t-} | Low Level Input Voltage | 3.0 | T _A =Worst Case | | | 0.5 | | 0.5 | | 0.5 | V |
| | | 4.5 | | | | 0.9 | | 0.9 | | 0.9 | |
| | | 5.5 | | | | 1.1 | | 1.1 | | 1.1 | |
| V _h | Hysteresis Voltage | 3.0 | T _A =Worst Case | 0.3 | | 1.2 | 0.3 | 1.2 | | 1.2 | V |
| | | 4.5 | | 0.4 | | 1.4 | 0.4 | 1.4 | | 1.4 | |
| | | 5.5 | | 0.5 | | 1.6 | 0.5 | 1.6 | | 1.6 | |
| V _{OH} | High Level Output Voltage | 3.0 | I _O =-50 μA | 2.9 | 2.99 | | 2.9 | | 2.9 | | V |
| | | 4.5 | I _O =-50 μA | 4.4 | 4.49 | | 4.4 | | 4.4 | | |
| | | 5.5 | I _O =-50 μA | 5.4 | 5.49 | | 5.4 | | 5.4 | | |
| | | 3.0 | I _O =-12 mA | 2.56 | | | 2.46 | | 2.46 | | |
| | | 4.5 | I _O =-24 mA | 3.86 | | | 3.76 | | 3.76 | | |
| | | 5.5 | I _O =-24 mA | 4.86 | | | 4.76 | | 4.76 | | |
| V _{OL} | Low Level Output Voltage | 3.0 | I _O =50 μA | | 0.002 | 0.1 | | 0.1 | | 0.1 | V |
| | | 4.5 | I _O =50 μA | | 0.001 | 0.1 | | 0.1 | | 0.1 | |
| | | 5.5 | I _O =50 μA | | 0.001 | 0.1 | | 0.1 | | 0.1 | |
| | | 3.0 | I _O =12 mA | | | 0.36 | | 0.44 | | 0.44 | |
| | | 4.5 | I _O =24 mA | | | 0.36 | | 0.44 | | 0.44 | |
| | | 5.5 | I _O =24 mA | | | 0.36 | | 0.44 | | 0.44 | |
| I _I | Input Leakage Current | 5.5 | V _I = V _{CC} or GND | | | ± 0.1 | | ± 1 | | ± 1 | μA |
| I _{CC} | Quiescent Supply Current | 5.5 | V _I = V _{CC} or GND | | | 4 | | 40 | | 40 | μA |
| I _{OLD} | Dynamic Output Current (note 1, 2) | 5.5 | V _{OLD} = 1.65 V max | | | | | 75 | | 50 | mA |
| I _{OHD} | | | V _{OHD} = 3.85 V min | | | | | -75 | | -50 | mA |

1) Maximum test duration 2ms, one output loaded at time

2) Incident wave switching is guaranteed on transmission lines with impedances as low as 50Ω

AC ELECTRICAL CHARACTERISTICS (C_L = 50 pF, R_L = 500 Ω, Input t_r = t_f = 3ns)

| Symbol | Parameter | Test Condition | | Value | | | | | | Unit | |
|-----------------------------------|------------------------|------------------------|--|-----------------------|------|------|-------------|------|--------------|------|------|
| | | V _{CC} (V) | | T _A = 25°C | | | -40 to 85°C | | -55 to 125°C | | |
| | | | | Min. | Typ. | Max. | Min. | Max. | Min. | | Max. |
| t _{PLH} t _{PHL} | Propagation Delay Time | 3.3(*) | | 1.5 | 6.0 | 11.0 | 1.0 | 15.0 | 1.0 | 16.0 | ns |
| | | 5.0(**) | | 1.5 | 4 | 8.0 | 1.0 | 11.0 | 1.0 | 12.0 | |

(*) Voltage range is 3.3V ± 0.3V

(**) Voltage range is 5.0V ± 0.5V

CAPACITIVE CHARACTERISTICS

| Symbol | Parameter | Test Condition | | Value | | | | | | Unit | |
|-----------------|--|---------------------|-------------------------|-----------------------|------|------|-------------|------|--------------|------|------|
| | | | | T _A = 25°C | | | -40 to 85°C | | -55 to 125°C | | |
| | | V _{CC} (V) | | Min. | Typ. | Max. | Min. | Max. | Min. | | Max. |
| C _{IN} | Input Capacitance | 5.0 | | | 4 | | | | | | pF |
| C _{PD} | Power Dissipation Capacitance (note 1) | 5.0 | f _{IN} = 10MHz | | 35 | | | | | | pF |

1) C_{PD} is defined as the value of the IC's internal equivalent capacitance which is calculated from the operating current consumption without load. (Refer to Test Circuit). Average operating current can be obtained by the following equation. I_{CC(opr)} = C_{PD} × V_{CC} × f_{IN} + I_{CC}/6 (per gate)

TEST CIRCUIT

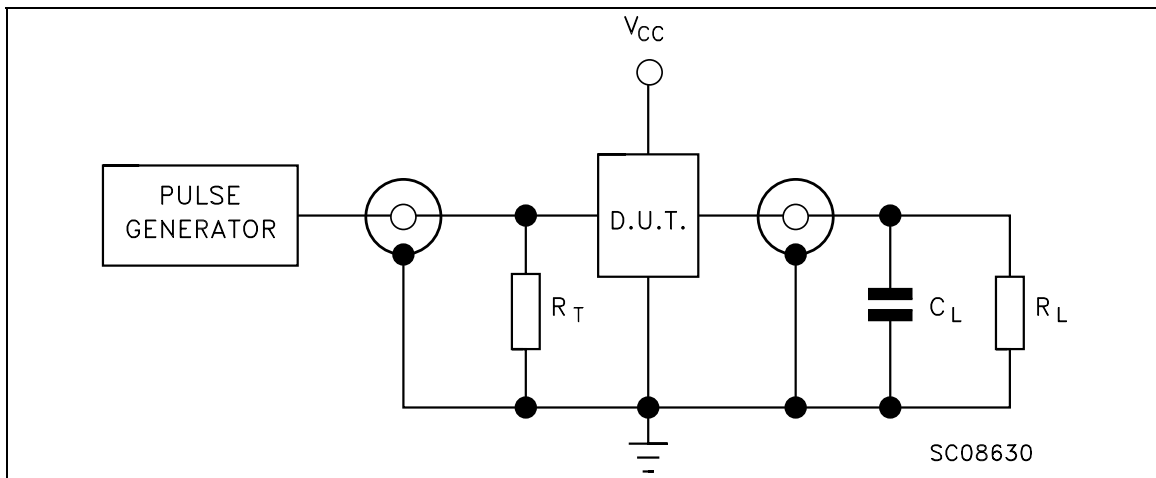

C_L = 50pF or equivalent (includes jig and probe capacitance)
 R_L = R₁ = 500Ω or equivalent
 R_T = Z_{OUT} of pulse generator (typically 50Ω)

WAVEFORM: PROPAGATION DELAYS (f=1MHz; 50% duty cycle)

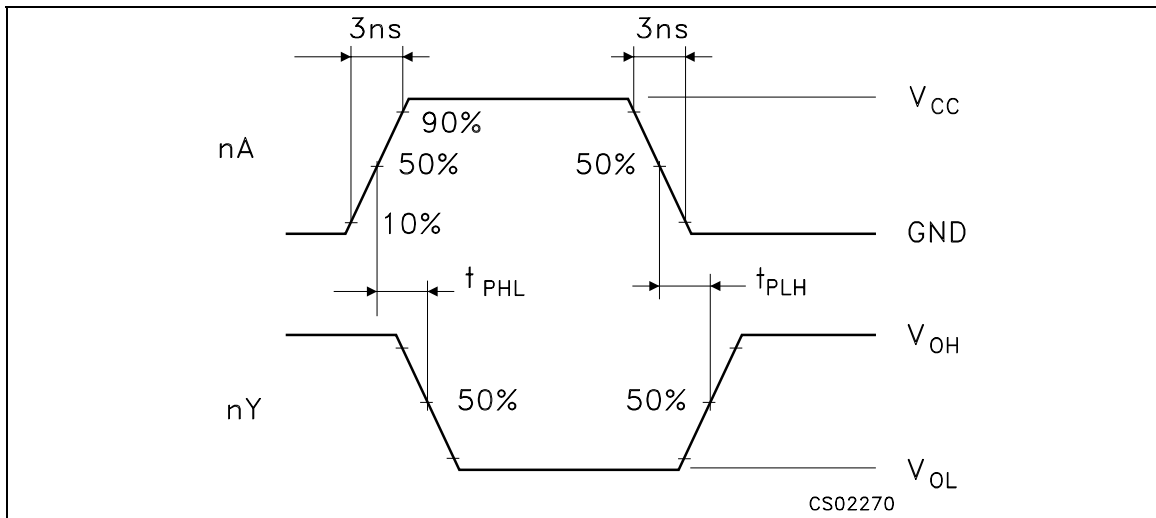

Plastic DIP-14 MECHANICAL DATA

| DIM. | mm. | | | inch | | |
|------|------|-------|------|-------|-------|-------|
| | MIN. | TYP | MAX. | MIN. | TYP. | MAX. |
| a1 | 0.51 | | | 0.020 | | |
| B | 1.39 | | 1.65 | 0.055 | | 0.065 |
| b | | 0.5 | | | 0.020 | |
| b1 | | 0.25 | | | 0.010 | |
| D | | | 20 | | | 0.787 |
| E | | 8.5 | | | 0.335 | |
| e | | 2.54 | | | 0.100 | |
| e3 | | 15.24 | | | 0.600 | |
| F | | | 7.1 | | | 0.280 |
| I | | | 5.1 | | | 0.201 |
| L | | 3.3 | | | 0.130 | |
| Z | 1.27 | | 2.54 | 0.050 | | 0.100 |

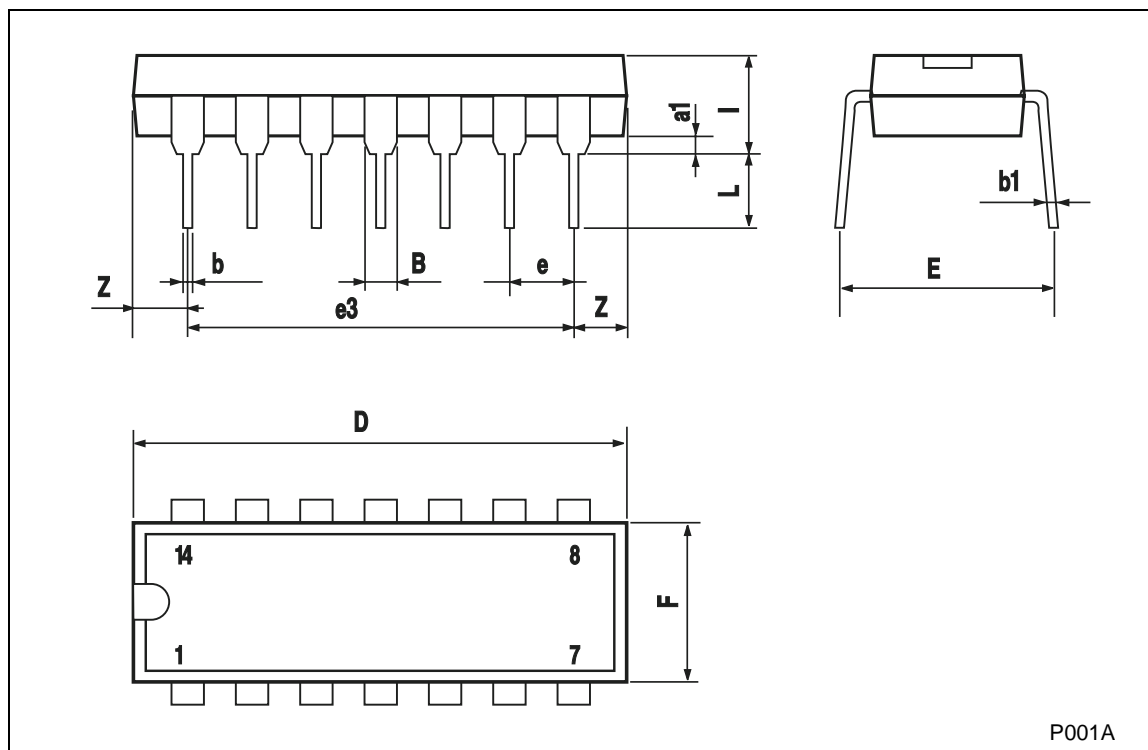

SO-14 MECHANICAL DATA

| DIM. | mm. | | | inch | | |
|------|------------|------|------|-------|-------|-------|
| | MIN. | TYP | MAX. | MIN. | TYP. | MAX. |
| A | | | 1.75 | | | 0.068 |
| a1 | 0.1 | | 0.2 | 0.003 | | 0.007 |
| a2 | | | 1.65 | | | 0.064 |
| b | 0.35 | | 0.46 | 0.013 | | 0.018 |
| b1 | 0.19 | | 0.25 | 0.007 | | 0.010 |
| C | | 0.5 | | | 0.019 | |
| c1 | 45° (typ.) | | | | | |
| D | 8.55 | | 8.75 | 0.336 | | 0.344 |
| E | 5.8 | | 6.2 | 0.228 | | 0.244 |
| e | | 1.27 | | | 0.050 | |
| e3 | | 7.62 | | | 0.300 | |
| F | 3.8 | | 4.0 | 0.149 | | 0.157 |
| G | 4.6 | | 5.3 | 0.181 | | 0.208 |
| L | 0.5 | | 1.27 | 0.019 | | 0.050 |
| M | | | 0.68 | | | 0.026 |
| S | 8° (max.) | | | | | |

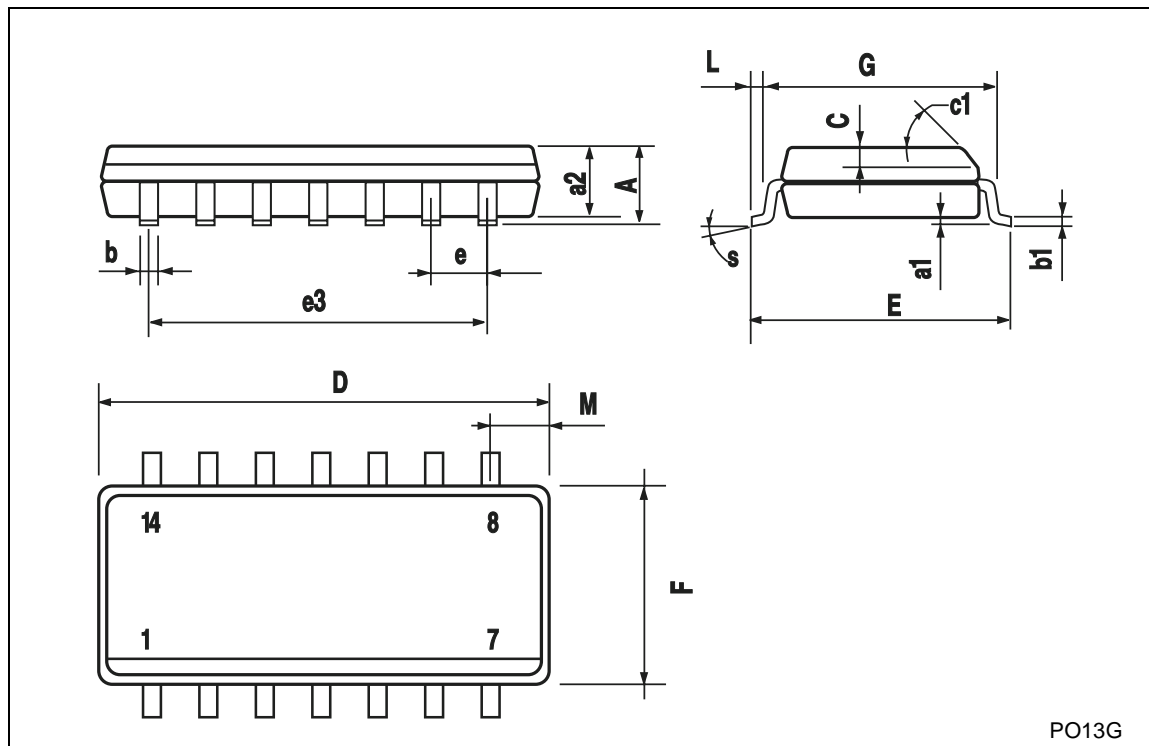

PO13G

TSSOP14 MECHANICAL DATA

| DIM. | mm. | | | inch | | |
|------|------|----------|------|-------|------------|--------|
| | MIN. | TYP | MAX. | MIN. | TYP. | MAX. |
| A | | | 1.2 | | | 0.047 |
| A1 | 0.05 | | 0.15 | 0.002 | 0.004 | 0.006 |
| A2 | 0.8 | 1 | 1.05 | 0.031 | 0.039 | 0.041 |
| b | 0.19 | | 0.30 | 0.007 | | 0.012 |
| c | 0.09 | | 0.20 | 0.004 | | 0.0089 |
| D | 4.9 | 5 | 5.1 | 0.193 | 0.197 | 0.201 |
| E | 6.2 | 6.4 | 6.6 | 0.244 | 0.252 | 0.260 |
| E1 | 4.3 | 4.4 | 4.48 | 0.169 | 0.173 | 0.176 |
| e | | 0.65 BSC | | | 0.0256 BSC | |
| K | 0° | | 8° | 0° | | 8° |
| L | 0.45 | 0.60 | 0.75 | 0.018 | 0.024 | 0.030 |

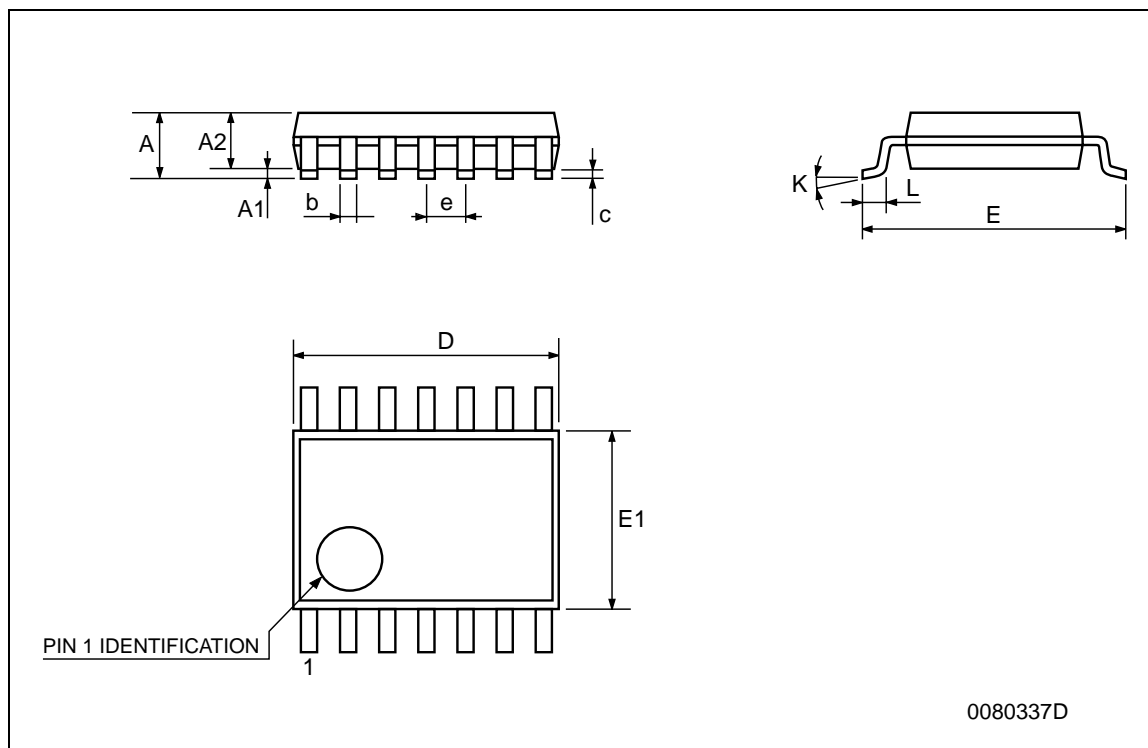

Information furnished is believed to be accurate and reliable. However, STMicroelectronics assumes no responsibility for the consequences of use of such information nor for any infringement of patents or other rights of third parties which may result from its use. No license is granted by implication or otherwise under any patent or patent rights of STMicroelectronics. Specifications mentioned in this publication are subject to change without notice. This publication supersedes and replaces all information previously supplied. STMicroelectronics products are not authorized for use as critical components in life support devices or systems without express written approval of STMicroelectronics.

© The ST logo is a registered trademark of STMicroelectronics

© 2001 STMicroelectronics - Printed in Italy - All Rights Reserved
STMicroelectronics GROUP OF COMPANIES

Australia - Brazil - China - Finland - France - Germany - Hong Kong - India - Italy - Japan - Malaysia - Malta - Morocco
Singapore - Spain - Sweden - Switzerland - United Kingdom

© <http://www.st.com>