

---

**MSDC22D-38KX3 PC-2100 CL2.5 200pin DDR SO-DIMM**  
**64Mx64 DDR SO-DIMM based on 32Mx8 DDR SDRAMs with SPD**

---

**DESCRIPTION**

The MSDC22D-38KX3 is 64M bit × 64 Double Data Rate Synchronous Dynamic RAM high density memory module.

The MSDC22D-38KX3 consists of sixteen CMOS 32M × 8 bit with 4 banks Double Data Rate Synchronous DRAMs in 60ball TinyBGA Advance package mounted on a 200-Pin glass-epoxy substrate. Two 0.1μF decoupling capacitors are mounted on the printed circuit board in parallel for each DDR SDRAM.

The MSDC22D-38KX3 is a Small Outline Dual In-line Memory Module and is intended for mounting into 200-Pin edge connector sockets.

Synchronous design allows precise cycle control with the use of system clock. Data I/O transactions are possible on both edges of every clock cycle. Range of operating frequencies, programmable latencies and burst lengths allows the same device to be useful for a variety of high bandwidth, high performance memory system applications.

**FEATURES**

- Performance range - 133MHz (Max Freq. ) ( CL=2.5 )
- Double-data-rate architecture; two data transfers per clock cycle
- Bi-directional data strobe (DQS)
- Differential clock inputs (CK and /CK)
- DLL aligns DQ and DQS transition with CK transition
- Auto & self refresh, 7.8us refresh interval (8K/64ms refresh)
- Power supply :  $V_{DD}$ : 2.5V ± 0.2V,  $V_{DDQ}$ : 2.5V ± 0.2V
- Programmable Burst length (2, 4, 8)
- Programmable Burst type (Sequential & Interleave)
- Edge aligned data output, center aligned data input
- Serial presence detect with EEPROM
- PCB : Height (1,250 mil), double sided component

**PIN CONFIGURATIONS (Front side/Back side)**

Pin	Front	Pin	Back	Pin	Front	Pin	Back
1	VREF	2	VREF	101	A9	102	A8
3	V <sub>SS</sub>	4	V <sub>SS</sub>	103	V <sub>SS</sub>	104	V <sub>SS</sub>
5	DQ0	6	DQ4	105	A7	106	A6
7	DQ1	8	DQ5	107	A5	108	A4
9	V <sub>DD</sub>	10	V <sub>DD</sub>	109	A3	110	A2
11	DQS0	12	DM0	111	A1	112	A0
13	DQ2	14	DQ6	113	V <sub>DD</sub>	114	V <sub>DD</sub>
15	V <sub>SS</sub>	16	V <sub>SS</sub>	115	A10/AP	116	BA1
17	DQ3	18	DQ7	117	BA0	118	/RAS
19	DQ8	20	DQ12	119	/WE	120	/CAS
21	V <sub>DD</sub>	22	V <sub>DD</sub>	121	/CS0	122	/CS1
23	DQ9	24	DQ13	123	*DU	124	*DU
25	DQS1	26	DM1	125	V <sub>SS</sub>	126	V <sub>SS</sub>
27	V <sub>SS</sub>	28	V <sub>SS</sub>	127	DQ32	128	DQ36
29	DQ10	30	DQ14	129	DQ33	130	DQ37
31	DQ11	32	DQ15	131	V <sub>DD</sub>	132	V <sub>DD</sub>
33	V <sub>DD</sub>	34	V <sub>DD</sub>	133	DQS4	134	DM4
35	CK0	36	V <sub>DD</sub>	135	DQ34	136	DQ38
37	/CK0	38	V <sub>SS</sub>	137	V <sub>SS</sub>	138	V <sub>SS</sub>
39	V <sub>SS</sub>	40	V <sub>SS</sub>	139	DQ35	140	DQ39
41	DQ16	42	DQ20	141	DQ40	142	DQ44
43	DQ17	44	DQ21	143	V <sub>DD</sub>	144	V <sub>DD</sub>
45	V <sub>DD</sub>	46	V <sub>DD</sub>	145	DO41	146	DO45
47	DQS2	48	DM2	147	DQS5	148	DM5
49	DQ18	50	DQ22	149	V <sub>SS</sub>	150	V <sub>SS</sub>
51	V <sub>SS</sub>	52	V <sub>SS</sub>	151	DQ42	152	DQ46
53	DQ19	54	DQ23	153	DQ43	154	DQ47
55	DQ24	56	DQ28	155	V <sub>DD</sub>	156	V <sub>DD</sub>
57	V <sub>DD</sub>	58	V <sub>DD</sub>	157	V <sub>DD</sub>	158	/CK1
59	DQ25	60	DQ29	159	V <sub>SS</sub>	160	CK1
61	DQS3	62	DM3	161	V <sub>SS</sub>	162	V <sub>SS</sub>
63	V <sub>SS</sub>	64	V <sub>SS</sub>	163	DQ48	164	DQ52
65	DQ26	66	DQ30	165	DQ49	166	DQ53
67	DQ27	68	DQ31	167	V <sub>DD</sub>	168	V <sub>DD</sub>
69	V <sub>DD</sub>	70	V <sub>DD</sub>	169	DQ56	170	DM6
71	*CB0	72	*CB4	171	DQ50	172	DQ54
73	*CB1	74	*CB5	173	V <sub>SS</sub>	174	V <sub>SS</sub>
75	V <sub>SS</sub>	76	V <sub>SS</sub>	175	DQ51	176	DQ55
77	*DQS8	78	*DM8	177	DQ56	178	DQ60
79	*CB2	80	*CB6	179	V <sub>DD</sub>	180	V <sub>DD</sub>
81	V <sub>DD</sub>	82	V <sub>DD</sub>	181	DQ57	182	DQ61
83	*CB3	84	*CB7	183	DQS7	184	DM7
85	*DU	86	*DU	185	V <sub>SS</sub>	186	V <sub>SS</sub>
87	V <sub>SS</sub>	88	V <sub>SS</sub>	187	DQ58	188	DQ62
89	*CK2	90	V <sub>SS</sub>	189	DQ59	190	DQ63
91	*/CK2	92	V <sub>DD</sub>	191	V <sub>DD</sub>	192	V <sub>DD</sub>
93	V <sub>DD</sub>	94	V <sub>DD</sub>	193	SDA	194	SA0
95	CKE1	96	CKE0	195	SCL	196	SA1
97	*A13	98	BA2	197	V <sub>DD</sub> SPD	198	SA2
99	A12	100	A11	199	*V <sub>DD</sub> ID	200	*DU

**PIN NAME**

Pin Name	Function
A0 ~ A12	Address input (Multiplexed)
BA0 , BA1	Select bank
DQ0 ~ DQ63	Data input/output
DQS0 ~ DQS7	Data Strobe input/output
CK0 , CK1	Clock input
/CK0 , /CK1	Clock input
CKE0 , CKE1	Clock enable input
/CS0 , /CS1	Chip select input
/RAS	Row address strobe
/CAS	Column address strobe
/WE	Write enable
DM0 ~ DM7	Data-in mask
V <sub>DD</sub>	Power supply (2.5V)
V <sub>SS</sub>	Ground
VREF	Power supply for reference
V <sub>DD</sub> SPD	Serial EEPROM power supply
SDA	Serial data I/O
SCL	Serial clock
SA0 ~ SA2	Address in EEPROM
V <sub>DD</sub> ID	VDD identification flag
DU	Don't use
NC	No connection

\* These pins are not used in this module.

### FUNCTIONAL BLOCK DIAGRAM

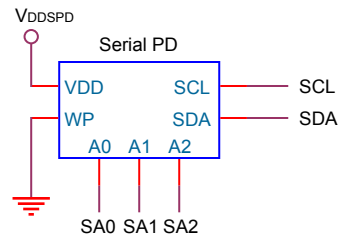
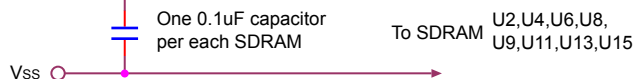
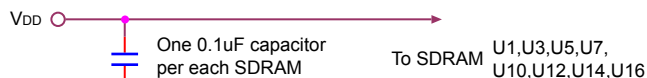
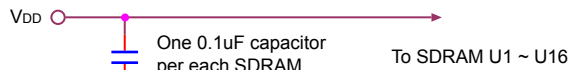
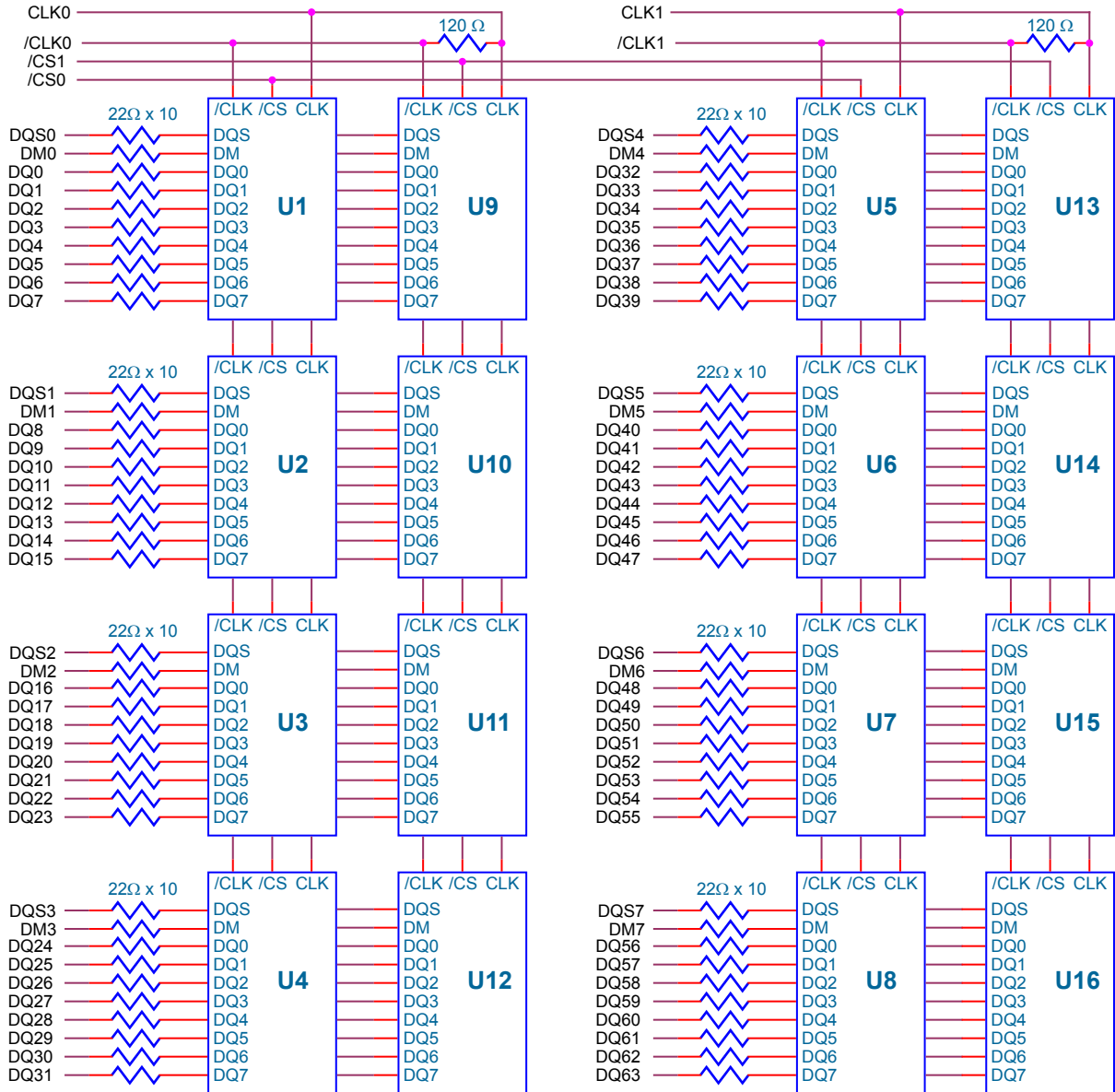

**ABSOLUTE MAXIMUM RATINGS**

Parameter	Symbol	Value	Unit
Supply voltage relative to $V_{SS}$	$V_{DD}$	-1.0 ~ 3.6	V
I/O Supply voltage relative to $V_{SS}$	$V_{DDQ}$	-1.0 ~ 3.6	V
I/O pins voltage relative to $V_{SS}$	$V_{IN}, V_{OUT}$	-0.5 ~ 3.6	V
Storage temperature	$T_{STG}$	-55 ~ +125	°C
Power dissipation	$P_D$	16	W
Short circuit current	$I_{OS}$	50	mA

Note: Permanent device damage may occur if “ABSOLUTE MAXIMUM RATINGS” are exceeded. Functional operation should be restricted to recommended operating condition.

Exposure to higher than recommended voltage for extended periods of time affect device reliability.

**DC OPERATING CONDITIONS AND CHARACTERISTICS (SSTL\_2 In/Out)**

Recommended operating conditions ( $T_A = 0$  to  $70^\circ\text{C}$ ,  $V_{DD} = +2.5\text{V} \pm 0.2\text{V}$ )

Parameter	Symbol	Min	Max	Unit	Note
Supply Voltage	$V_{DD}$	2.3	2.7	V	
I/O Supply Voltage	$V_{DDQ}$	2.3	2.7	V	
I/O Reference voltage	$V_{REF}$	$0.49 \times V_{DDQ}$	$0.51 \times V_{DDQ}$	V	1
I/O Termination voltage (system)	$V_{TT}$	$V_{REF} - 0.04$	$V_{REF} + 0.04$	V	2
Input logic high voltage	$V_{IH(DC)}$	$V_{REF} + 0.15$	$V_{DD} + 0.3$	V	3
Input logic low voltage	$V_{IL(DC)}$	-0.3	$V_{REF} - 0.15$	V	3
Input voltage level, CK and /CK inputs	$V_{IN(DC)}$	-0.3	$V_{DD} + 0.3$	V	
Input differential voltage, CK and /CK inputs	$V_{ID(DC)}$	0.3	$V_{DD} + 0.6$	V	4
Output high current ( $V_{OUT} = 1.95\text{V}$ )	$I_{OH}$	16.8	-	mA	
Output low current ( $V_{OUT} = 0.35\text{V}$ )	$I_{OL}$	-16.8	-	mA	
Input leakage current	$I_I$	-16	16	$\mu\text{A}$	5
Output leakage current	$I_{OZ}$	-40	40	$\mu\text{A}$	6

Note : 1.  $V_{REF}$  is expected to be equal to  $0.5 \times V_{DDQ}$  of the transmitting devices, and must track variations in the DC level of the same. Peak-to-peak noise on  $V_{REF}$ , may not exceed 2% of the DC value.

2.  $V_{TT}$  is not applied directly to the device.  $V_{TT}$  is a system supply for signal termination resistors, is expected to be set equal to  $V_{REF}$ , and must track variations in the DC level of  $V_{REF}$ .

3. These parameters should be tested at the pin on actual components. The AC and DC input specifications are relative to a  $V_{REF}$  envelop that has been bandwidth limited to 200MHz.

4.  $V_{ID}$  is the magnitude of the difference between the input level on CK and the input on /CK.

5. Any input  $0\text{V} \leq V_{IN} \leq V_{DDQ}$ ,  $V_{REF}$  pin  $0\text{V} \leq V_{IN} \leq 1.35\text{V}$ , All other pins not under test = 0 V

6.  $0\text{V} \leq V_{OUT} \leq V_{DDQ}$ , DQs are disabled.

**I<sub>DD</sub> CONDITIONS AND SPECIFICATIONS**

 Recommended operating conditions unless otherwise noted, T<sub>A</sub> = 0 to 70°C, V<sub>DD</sub> = +2.5V ±0.2V

Parameter / Condition	Symbol	Max	Unit	Note
<b>Operating current - One bank; Active-Precharge;</b> tRC = tRC(Min); tCK = tCK(Min); DQ, DM and DQS inputs changing once per clock cycle; Address and control inputs changing once every two clock cycles	I <sub>DD0</sub>	1080	mA	
<b>Operating current - One bank; Active-Read-Precharge;</b> Burst = 2; tRC = tRC(Min); tCK = tCK(Min); I <sub>OUT</sub> = 0 mA; Address and control inputs changing once per clock cycle	I <sub>DD1</sub>	1520	mA	
<b>Precharge power-down standby current;</b> All banks idle; Power-down Mode; tCK = tCK(Min); CKE = LOW	I <sub>DD2P</sub>	24	mA	
<b>Idle standby current;</b> /CS = HIGH; All banks idle; tCK = tCK(Min); CKE = HIGH; Address and control inputs changing once per clock cycle; V <sub>IN</sub> = V <sub>REF</sub> for DQ, DQS and DM	I <sub>DD2F</sub>	280	mA	
<b>Active power-down standby current;</b> One banks active; Power-down Mode; tCK = tCK(Min); CKE = LOW	I <sub>DD3P</sub>	32	mA	
<b>Active standby current;</b> /CS = HIGH; CKE = HIGH; One bank; Active-Precharge; tRC = tRAS(Max); tCK = tCK(Min) ; DQ, DM and DQS inputs changing twice per clock cycle; Address and other control inputs changing once pre clock cycles	I <sub>DD3N</sub>	280	mA	
<b>Operating current;</b> Burst = 2; Reads; Continuous burst; One bank active; Address and control inputs changing once per clock cycle; tCK = tCK(Min); I <sub>OUT</sub> = 0 mA	I <sub>DD4R</sub>	1640	mA	
<b>Operating current;</b> Burst = 2; Writes; Continuous burst; One bank active; Address and control inputs changing once per clock cycle; tCK = tCK(Min); DQ, DM and DQS inputs changing twice per clock cycle	I <sub>DD4W</sub>	1520	mA	
<b>Auto refresh current</b>	tRC = tRC(Min)	I <sub>DD5</sub>	2000	mA
	tRC = 15.625μs	I <sub>DD5A</sub>	48	mA
<b>Self refresh current;</b> CKE ≤ 0.2V	I <sub>DD6</sub>	24	mA	
<b>Operating current;</b> Four bank interleaving READs with BL = 4; Auto Precharge; tRC = tRC(min); tCK = tCK(min); Address and control inputs change only Active READ or WRITE commands	I <sub>DD7</sub>	2400	mA	

## AC INPUT OPERATING CONDITIONS

Recommended operating conditions ( $T_A = 0$  to  $70^\circ\text{C}$ ,  $V_{DD} = +2.5\text{V} \pm 0.2\text{V}$ )

Parameter / Condition	Symbol	Min	Max	Unit	Note
Input logic high voltage	$V_{IH(AC)}$	$V_{REF}+0.31$	-	V	1
Input logic low voltage	$V_{IL(AC)}$	-	$V_{REF}-0.31$	V	1
Input differential voltage, CK and /CK inputs	$V_{ID(DC)}$	0.7	$V_{DD}+0.6$	V	2
Input crossing point voltage, CK and /CK inputs	$V_{IX(DC)}$	$0.5 \times V_{DD}-0.2$	$0.5 \times V_{DD}+0.2$	V	3

- Note :
1. These parameters should be tested at the pin on actual components. The AC and DC input specifications are relative to a  $V_{REF}$  envelop that has been bandwidth limited to 200MHz.
  2.  $V_{ID}$  is the magnitude of the difference between the input level on CK and the input on /CK.
  3. The value of  $V_{IX}$  is expected to be equal  $0.5 \times V_{DD}$  of the transmitting device and must track variations in the DC level of the same.

## AC OPERATING TEST CONDITIONS ( $T_A = 0$ to $70^\circ\text{C}$ , $V_{DD} = +2.5\text{V} \pm 0.2\text{V}$ )

Parameter	Value	Unit
Input reference voltage for Clock	$0.5 \times V_{DD}$	V
Input signal maximum peak swing	1.5	V
Input Levels( $V_{IH}/V_{IL}$ )	$V_{REF}+0.31 / V_{REF}-0.31$	V
Input timing measurement reference level	$V_{REF}$	V
Output timing measurement reference level	$V_{tt}$	V
Output load condition	See Load Circuit	

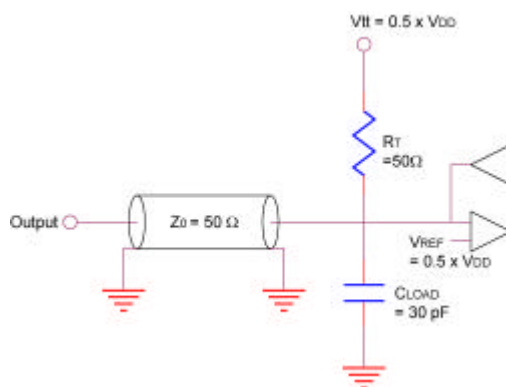

Output Load Circuit (SSTL\_2)

**AC TIMMING PARAMETERS AND SPECIFICATIONS**

(These AC characteristics were tested on the component)

Parameter	Symbol	Min	Max	Unit	Note	
Row cycle time	tRC	65	-	ns		
Refresh row cycle time	tRFC	75	-	ns		
Row active time	tRAS	45	120K	ns		
/RAS to /CAS delay	tRCD	20		ns		
Row precharge time	tRP	20		ns	5	
Row active to Row active delay	tRRD	15		ns	5	
Write recovery time	tWR	2		tCK		
Last data in to Read command	tCDLR	1		tCK		
Col. address to Col. address delay	tCCD	1		tCK		
Clock cycle time	tCK	CL = 2.0	10	13	ns	5
		CL = 2.5	7.5	13		
Clock high level width	tCH	0.45	0.55	tCK		
Clock low level width	tCL	0.45	0.55	tCK		
DQS-out access time from CK, /CK	tDQSCK	-0.75	+0.75	ns		
Output data access time from CK, /CK	tAC	-0.75	+0.75	ns		
Data strobe edge to output data edge	tDQSQ	-	+0.5	ns		
Read Preamble	tRPRE	0.9	1.1	tCK		
Read Post amble	tRPST	0.4	0.6	tCK		
CK to valid DQS-in	tDQSS	0.75	1.25	tCK		
DQS-in setup time	tWPRES	0		ns	2	
DQS-in hold time	tWPREH	0.25		tCK		
DQS falling edge to CK rising-setup time	tDSS	0.2		tCK		
DQS falling edge from CK rising-hold time	tDSH	0.2		tCK		
DQS-in high level width	tDQSH	0.35		tCK		
DQS-in low level width	tDQSL	0.35		tCK		
DQS-in cycle time	tDSC	0.9	1.1	tCK		
Address and Control Input setup time	tIS	1		ns	6	
Address and Control Input hold time	tIH	1		ns	6	
Data-out high impedance time from CK, /CK	tHZ	tACmin - 400ps	tACmax - 400ps	ps		
Data-out low impedance time from CK, /CK	tLZ	tACmin - 400ps	tACmax - 400ps	ps		
Input Slew Rate (for input only pins)	tSL(I)	0.5		V/ns	6	
Input Slew Rate (for I/O pins)	tSL(IO)	0.5		V/ns	7	
Output Slew Rate (x8)	tSL(O)	1.0	4.5	V/ns	10	
Output Slew Rate Matching Ratio (rise to fall)	tSLMR	0.67	1.5			

Parameter	Symbol	Min	Max	Unit	Note
Mode register set cycle time	tMRD	15		ns	
DQ & DM setup time to DQS	tDS	0.5		ns	7,8,9
DQ & DM hold time to DQS	tDH	0.5		ns	7,8,9
DQ & DM input pulse width	tDIPW	1.75		ns	
Power down exit time	tPDEX	10		ns	
Exit self refresh to write command	tXSW	95		ns	
Exit self refresh to bank active command	tXSA	75		ns	4
Exit self refresh to read command	tXSR	200		Cycle	
Refresh interval time	tREF	7.8		us	1
Output DQS valid window	tQH	tHPmin - tQHS		ns	5
Clock half period	tHP	tCLmin or tCHmin		ns	
Data hold skew factor	tQHS		0.75	ns	
DQS write postamble time	tWPST	0.25		tCK	3

Note : 1. Maximum burst refresh of 8

- The specific requirement is that DQS be valid (High or Low) on or before this CK edge. The case shown (DQS going from High\_Z to logic Low) applies when no writes were previously in progress on the bus. If a previous write was in progress, DQS could be High at this time, depending on tDQSS.
- The maximum limit for this parameter is not a device limit. The device will operate with a great value for this parameter, but system performance (bus turnaround) will degrade accordingly.
- A write command can be applied with tRCD satisfied after this command.
- For registered DIMMs, tCL and tCH are  $\geq 45\%$  of the period including both the half period jitter (tJIT(HP)) of the PLL and the half period jitter due to cross talk (tJIT(crosstalk)) on the DIMM.
- Input Setup/Hold Slew Rate Derating

Input Setup/Hold Slew Rate (V/ns)	$\Delta t_{IS}$ (ps)	$\Delta t_{IH}$ (ps)
0.5	0	0
0.4	+50	+50
0.3	+100	+100

This derating table is used to increase tIS /tIH in the case where the input slew rate is below 0.5V/ns. Input setup/hold slew rate based on the lesser of AC-AC slew rate and DC-DC slew rate.



## 7. I/O Setup/Hold Slew Rate Derating

I/O Setup/Hold Slew Rate (V/ns)	$\Delta t_{IS}$ (ps)	$\Delta t_{IH}$ (ps)
0.5	0	0
0.4	+75	+75
0.3	+150	+150

This derating table is used to increase  $t_{DS}$  / $t_{DH}$  in the case where the I/O slew rate is below 0.5V/ns. I/O setup/hold slew rate based on the lesser of AC-AC slew rate and DC-DC slew rate.

## 8. I/O Setup/Hold Plateau Derating

I/O Input Level (mV)	$\Delta t_{IS}$ (ps)	$\Delta t_{IH}$ (ps)
$\pm 280$	+50	+50

This derating table is used to increase  $t_{DS}$  / $t_{DH}$  in the case where the input level is flat below  $V_{REF} \pm 310\text{mV}$  for a duration of up to 2ns.

## 9. I/O Delta Rise/Fall Rate(1/slew-rate) Derating

Delta Rise/Fall Rate (ns/V)	$\Delta t_{IS}$ (ps)	$\Delta t_{IH}$ (ps)
0	0	0
$\pm 0.25$	+50	+50
$\pm 0.5$	+100	+100

This derating table is used to increase  $t_{DS}$ / $t_{DH}$  in the case where the DQ and DQS slew rates differ. The Delta Rise/Fall Rate is collated as  $1/\text{SlewRate1}-1/\text{SlewRate2}$ . For example, if slew rate 1 = 5V/ns and slew rate 2 = 4V/ns then the Delta Rise/Fall Rate = 0.5ns/V. Input S/H slew rate based on larger of AC-AC delta rise/fall rate and DC-DC delta rise/fall rate.

10. This parameter is for system simulation purpose. It is guaranteed by design.

**CAPACITANCE**

( $V_{DD} = 2.5\text{V}$ ,  $T_A = 25^\circ\text{C}$ ,  $f = 1\text{MHz}$ ,  $V_{REF} = 1.25\text{V} \pm 100\text{mV}$ )

Pin	Symbol	Min	Max	Unit
Input Capacitance: Command and Address	$C_{IN1}$	20	30	pF
Input Capacitance: /CS0, /CS1	$C_{IN2}$	20	30	pF
Input Capacitance: CK0, /CK0, CK1, /CK1	$C_{IN3}$	15	20	pF
Input Capacitance: CKE0, CKE1	$C_{IN4}$	16	24	pF
Input/Output Capacitance: DQs, DQS	$C_{I/O}$	8	12	pF

### COMMAND TRUTH TABLE

Command		CKE <sub>n-1</sub>	CKE <sub>n</sub>	/CS	/RAS	/CAS	/WE	BA <sub>0,1</sub>	A <sub>10</sub> /AP	A <sub>12</sub> ,A <sub>11</sub> , A <sub>9</sub> ~A <sub>0</sub>	Note	
Register	Extended MRS	H	X	L	L	L	L	OP code			1, 2	
Register	Mode Register Set	H	X	L	L	L	L	OP code			1, 2	
Refresh	Auto Refresh		H	H	L	L	L	H	X		3	
	Entry			L							3	
	Self Refresh		L	H	L	H	H	H	X		3	
	Exit				H	X	X	X			3	
Bank Active & Row Address		H	X	L	L	H	H	V	Row address			
Read & Column Address	Auto Precharge Disable		H	X	L	H	L	H	V	L	Column address (A <sub>0</sub> ~A <sub>9</sub> )	4
	Auto Precharge Enable								H	4		
Write & Column Address	Auto Precharge Disable		H	X	L	H	L	L	V	L	Column address (A <sub>0</sub> ~A <sub>9</sub> )	4
	Auto Precharge Enable								H	4, 6		
Burst Stop		H	X	L	H	H	L	X			7	
Precharge	Bank Selection		H	X	L	L	H	L	V	L	X	
	All Banks								X	H		5
Active Power Down		Entry	H	L	H	X	X	X	X			
					L	V	V	V				
Precharge Power Down Mode		Exit	L	H	X	X	X	X	X			
					L	V	V	V				
DM		H	X					X			8	
No operation (NOP) : Not defined		H	X	H	X	X	X	X			9	
				L	H	H	H			9		

(V = Valid, X = Don't Care, H = Logic High, L = Logic Low)

Note : 1. OP Code : Operand Code. A<sub>0</sub> ~ A<sub>11</sub> & BA<sub>0</sub> ~ BA<sub>1</sub> : Program keys. (@EMRS/MRS)

2. EMRS/ MRS can be issued only at all banks precharge state.

A new command can be issued 2 clock cycles after EMRS or MRS.

3. Auto refresh functions are same as the CBR refresh of DRAM.

The automatically precharge without row precharge command is meant by "Auto".

Auto/self refresh can be issued only at all banks precharge state.

4. BA<sub>0</sub> ~ BA<sub>1</sub> : Bank select addresses.

If both BA<sub>0</sub> and BA<sub>1</sub> are "Low" at read, write, row active and precharge, bank A is selected.

If both BA<sub>0</sub> is "High" and BA<sub>1</sub> is "Low" at read, write, row active and precharge, bank B is selected.

If both BA<sub>0</sub> is "Low" and BA<sub>1</sub> is "High" at read, write, row active and precharge, bank C is selected.

If both BA<sub>0</sub> and BA<sub>1</sub> are "High" at read, write, row active and precharge, bank D is selected.

5. If A<sub>10</sub>/AP is "High" at row precharge, BA<sub>0</sub> and BA<sub>1</sub> are ignored and all banks are selected.

6. During burst write with auto precharge, new read/write command can not be issued.

Another bank read/write command can be issued after the end of burst.

New row active of the associated bank can be issued at tRP after the end of burst.

7. Burst stop command is valid at every burst length.

8. DM sampled at the rising and falling edges of the DQS and Data-in are masked at the both edges

(Write DM latency is 0).

9. This combination is not defined for any function, which means "No Operation (NOP)" in DDR

SDRAM.

## PACKAGE DIMENSIONS

Units : Millimeter

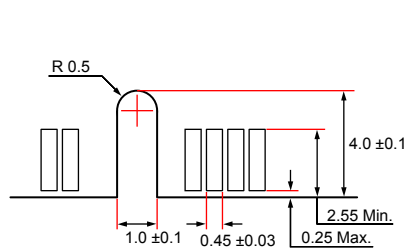
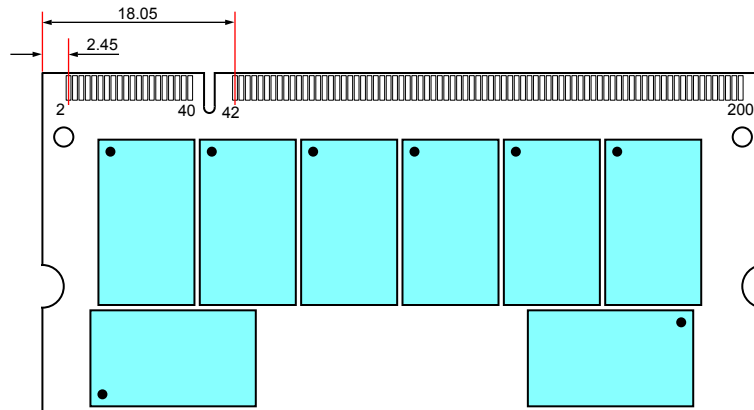
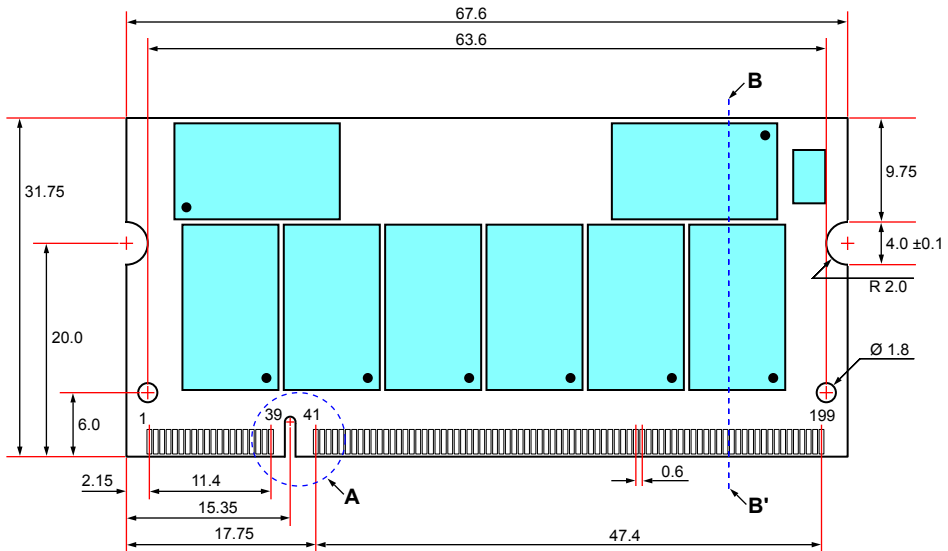

**Detail A**

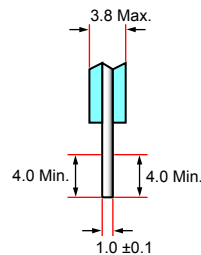

**Section B-B'**

Tolerance : ±0.15 unless otherwise specified

The used device is 32Mx8 DDR SDRAM TinyBGA

**SERIAL PRESENCE DETECT INFORMATION**

Byte #	Function described	Function Supported	Hex value
0	# of bytes written into serial memory at module manufacturer	128 bytes	80h
1	Total # of bytes of SPD memory device	256 bytes (2K-bit)	08h
2	Fundamental memory type	SDRAM DDR	07h
3	# of row address on this assembly	13	0Dh
4	# of column address on this assembly	10	0Ah
5	# of module banks on this assembly	2 banks	02h
6	Data width of this assembly	64 bits	40h
7	Data width of this assembly	-	00h
8	VDDQ and interface standard of this assembly	SSTL 2.5V	04h
9	DDR SDRAM cycle time from clock @CAS latency of 2.5	7.5ns	75h
10	DDR SDRAM access time from clock @CAS latency of 2.5	± 0.75ns	75h
11	DIMM configuration type (Non-parity , Parity , ECC )	None	00h
12	Refresh rate & type	7.81us, support self refresh	82h
13	Primary DDR SDRAM width	× 8	08h
14	Error checking DDR SDRAM data width	None	00h
15	Minimum clock delay for back-to-back random column	t <sub>CCD</sub> =1CLK	01h
16	DDR SDRAM device attributes: Burst lengths supported	2 , 4 , 8	0Eh
17	DDR SDRAM device attributes: # of banks on each DDR	4 banks	04h
18	DDR SDRAM device attributes: CAS Latency supported	2 & 2.5	0Ch
19	DDR SDRAM device attributes: CS Latency	0 CLK	01h
20	DDR SDRAM device attributes: WE Latency	1 CLK	02h
21	DDR SDRAM module attributes	Registered address Control inputs On-card DLL	20h
22	DDR SDRAM device attributes: General	± 0.2 voltage tolerance	00h
23	DDR SDRAM cycle time @CAS latency of 2	10ns	A0h
24	DDR SDRAM access time @CAS latency of 2	± 7.5ns	75h
25	SDRAM cycle time @CAS latency of 1.5	-	00h
26	SDRAM access time @CAS latency of 1.5	-	00h
27	Minimum row precharge time (=tRP)	20ns	50h
28	Minimum row active to row active delay (tRRD)	15ns	3Ch
29	Minimum RAS to CAS delay (=tRCD)	20ns	50h
30	Minimum activate precharge time (=tRAS)	45ns	2Dh
31	Module Row density	256MB	40h
32	Command and Address signal input setup time	1ns	A0h
33	Command and Address signal input hold time	1ns	A0h
34	Data signal input setup time	0.5ns	50h
35	Data signal input hold time	0.5ns	50h
36-61	Superset information (maybe used in future)	-	00h
62	SPD data revision code	Initial release	00h
63	Checksum for bytes 0 ~ 62		E0h

**SERIAL PRESENCE DETECT INFORMATION**

64	Manufacturer JEDEC ID code	kingmax	7Fh
65	Manufacturer JEDEC ID code	kingmax	7Fh
66	Manufacturer JEDEC ID code	kingmax	7Fh
67	Manufacturer JEDEC ID code	kingmax	25h
68~71	Manufacturer JEDEC ID code	-	00h
72	Manufacturing location	Hsin Chu (A)	41h
73	Manufacturer part # (Memory module)	M	4Dh
74	Manufacturer part # (184 pin DIMM)	S	53h
75	Manufacturer part # (DDR 333)	D	44h
76	Manufacturer part # (Module density: 256MB)	C	43h
77	Manufacturer part # (Module density: 256MB)	2	32h
78	Manufacturer part # (Vdd = 2.5V)	2	32h
79	Manufacturer part # (DDR SDRAM)	D	44h
80	Manufacturer part #	“-“	2Dh
81	Manufacturer part # (DDR SDRAM type: 16Mb × 8)	3	33h
82	Manufacturer part # (DDR SDRAM type: 16Mb × 8)	8	38h
83	Manufacturer part # (Kingmax logo)	K	4Bh
84	Manufacturer part # (Kingmax logo)	X	58h
85	Manufacturer part # (CL=2.5)	3	33h
86	Manufacturer part #	“-“	2Dh
87	Manufacturer part # (option for die source)	*	*
88	Manufacturer part # (option for module version)	*	*
89	Manufacturer part # (option for die version)	*	*
90	Manufacturer part # (reserve)	-	00h
91	Manufacturer revision code (reserve)	-	00h
92	Manufacturer revision code (reserve)	-	00h
93	Manufacturing date (Work Year) - BCD	2002	02h
94	Manufacturing date (Work Week) - BCD (reserve)	-	00h
95~98	Assemble serial # -BCD (reserve)	-	00h
99~125	Manufacturer specific data (may be used in future)	-	00h
126	Intel specification for frequency	Undefined	00h
127	Intel specification details for 100MHz support	Undefined	00h
128+	Unused storage locations	-	FFh