

DATA SHEET

TDA1519A

**22 W BTL or 2 x 11 W stereo car
radio power amplifier**

Product specification
File under Integrated Circuits, IC01

May 1992

22 W BTL or 2 x 11 W stereo car radio power amplifier

TDA1519A

GENERAL DESCRIPTION

The TDA1519A is an integrated class-B dual output amplifier in a 9-lead single in-line (SIL) plastic power package. The device is primarily developed for car radio applications.

Features

- Requires very few external components for Bridge Tied Load (BTL)
- Stereo or BTL application
- High output power
- Low offset voltage at output (important for BTL)
- Fixed gain
- Good ripple rejection
- Mute/stand-by switch
- Load dump protection
- AC and DC short-circuit-safe to ground and V_P
- Thermally protected
- Reverse polarity safe
- Capability to handle high energy on outputs ($V_P = 0$ V)
- No switch-on/switch-off plop
- Protected against electrostatic discharge
- Low thermal resistance
- Identical inputs (inverting and non-inverting)
- Compatible with TDA1519B (except output power).

QUICK REFERENCE DATA

PARAMETER	CONDITIONS	SYMBOL	MIN.	TYP.	MAX.	UNIT
Supply voltage range						
operating		V_P	6.0	14.4	17.5	V
non-operating		V_P	—	—	30	V
load dump protected		V_P	—	—	45	V
Repetitive peak output current		I_{ORM}	—	—	4	A
Total quiescent current		I_{tot}	—	40	80	mA
Stand-by current		I_{sb}	—	0.1	100	μ A
Switch-on current		I_{sw}	—	—	40	μ A
Input impedance						
BTL		$ Z_I $	25	—	—	k Ω
stereo		$ Z_I $	50	—	—	k Ω
Stereo application						
Output power	THD = 10%; 4 Ω	P_o	—	6	—	W
	THD = 10%; 2 Ω	P_o	—	11	—	W
Channel separation		α	40	—	—	dB
Noise output voltage		$V_{no(rms)}$	—	150	—	μ V

**22 W BTL or 2 x 11 W stereo car radio
power amplifier**

TDA1519A

PARAMETER	CONDITIONS	SYMBOL	MIN.	TYP.	MAX.	UNIT
BTL application						
Output power	THD = 10%; 4 Ω	P_o	–	22	–	W
Supply voltage ripple rejection	$R_S = 0 \Omega$					
	f = 100 Hz	RR	34	–	–	dB
	f = 1 kHz to 10 kHz	RR	48	–	–	dB
DC output offset voltage		$ \Delta V_0 $	–	–	250	mV
Crystal temperature		T_c	–	–	150	$^{\circ}\text{C}$

PACKAGE OUTLINES

9 lead SIL; plastic power (SOT131); SOT131-2; 1996 July 22.

9-lead SIL-bent-to-DIL; plastic power (SOT157); SOT157-2; 1996 July 22.

22 W BTL or 2 x 11 W stereo car radio
power amplifier

TDA1519A

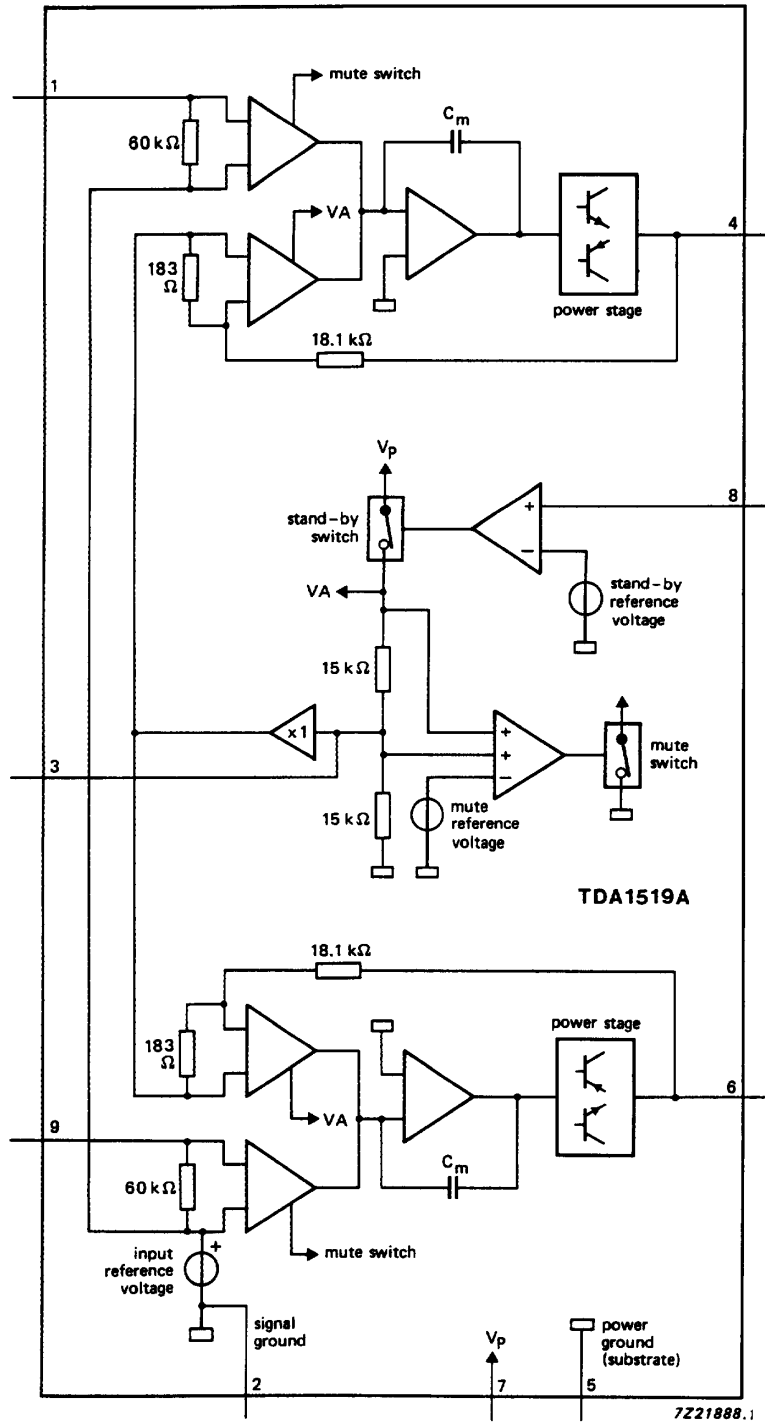

Fig.1 Block diagram.

22 W BTL or 2 x 11 W stereo car radio power amplifier

TDA1519A

PINNING

1	NINV	non-inverting input
2	GND1	ground (signal)
3	RR	supply voltage ripple rejection
4	OUT1	output 1
5	GND2	ground (substrate)
6	OUT2	output 2
7	V _P	positive supply voltage
8	M/SS	mute/stand-by switch
9	INV	inverting input

FUNCTIONAL DESCRIPTION

The TDA1519A contains two identical amplifiers with differential input stages. The gain of each amplifier is fixed at 40 dB. A special feature of this device is the mute/stand-by switch which has the following features:

- Low stand-by current (< 100 μ A)
- Low mute/stand-by switching current (low cost supply switch)
- Mute condition.

RATINGS

Limiting values in accordance with the Absolute Maximum System (IEC 134)

PARAMETER	CONDITIONS	SYMBOL	MIN.	MAX.	UNIT
Supply voltage					
operating		V _P	–	17.5	V
non-operating		V _P	–	30	V
load dump protected	during 50 ms; t _r ≥ 2.5 ms	V _P	–	45	V
AC and DC short-circuit-safe voltage		V _{PSC}	–	18	V
Reverse polarity		V _{PR}	–	6	V
Energy handling capability at outputs	V _P = 0 V		–	200	mJ
Non-repetitive peak output current		I _{OSM}	–	6	A
Repetitive peak output current		I _{ORM}	–	4	A
Total power dissipation	see Fig.2	P _{tot}	–	25	W
Crystal temperature		T _c	–	150	°C
Storage temperature range		T _{stg}	–55	+ 150	°C

22 W BTL or 2 x 11 W stereo car radio
power amplifier

TDA1519A

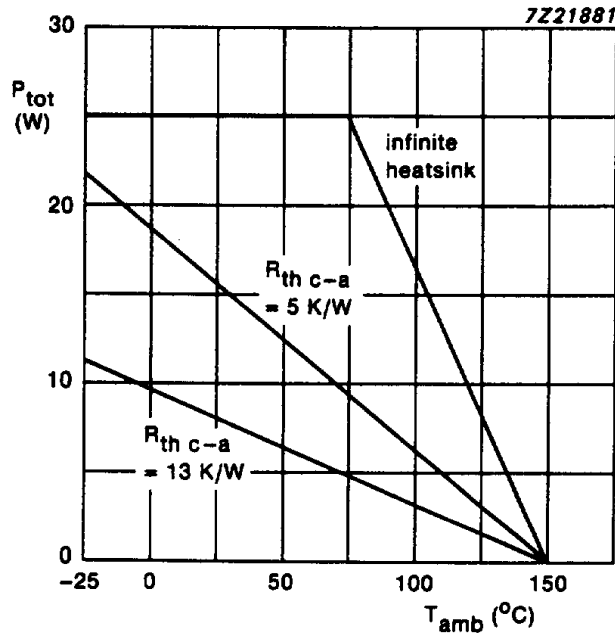

Fig.2 Power derating curve.

DC CHARACTERISTICS

$V_P = 14.4\ V$; $T_{amb} = 25\ ^\circ C$; measurements taken using Fig.3; unless otherwise specified

PARAMETER	CONDITIONS	SYMBOL	MIN.	TYP.	MAX.	UNIT
Supply						
Supply voltage range	note 1	V_P	6.0	14.4	17.5	V
Total quiescent current		I_{tot}	–	40	80	mA
DC output voltage	note 2	V_O	–	6.95	–	V
DC output offset voltage		$ \Delta V_{4-6} $	–	–	250	mV
Mute/stand-by switch						
Switch-on voltage level		V_{ON}	8.5	–	–	V
Mute condition						
Output signal in mute position	$V_I = 1\ V$ (max.); $f = 20\ Hz$ to 15 kHz	V_O	–	–	20	mV
DC output offset voltage		$ \Delta V_{4-6} $	–	–	250	mV

22 W BTL or 2 x 11 W stereo car radio power amplifier

TDA1519A

PARAMETER	CONDITIONS	SYMBOL	MIN.	TYP.	MAX.	UNIT
Stand-by condition		V_{sb}	0	–	2	V
DC current in stand-by condition		I_{sb}	–	–	100	μA
Switch-on current		I_{sw}	–	12	40	μA

AC CHARACTERISTICS

$V_P = 14.4\text{ V}$; $R_L = 4\ \Omega$; $f = 1\text{ kHz}$; $T_{amb} = 25\text{ }^\circ\text{C}$; measurements taken using Fig.3; unless otherwise specified

PARAMETER	CONDITIONS	SYMBOL	MIN.	TYP.	MAX.	UNIT
Stereo application						
Output power	note 3					
	THD = 0.5%	P_o	4	5	–	W
	THD = 10%	P_o	5.5	6.0	–	W
Output power at $R_L = 2\ \Omega$	note 3					
	THD = 0.5%	P_o	7.5	8.5	–	W
	THD = 10%	P_o	10	11	–	W
Total harmonic distortion	$P_o = 1\text{ W}$	THD	–	0.1	–	%
Low frequency roll-off	note 4					
	–3 dB	f_L	–	45	–	Hz
High frequency roll-off	–1 dB	f_H	20	–	–	kHz
Closed loop voltage gain		G_v	39	40	41	dB
Supply voltage ripple rejection						
ON	notes 5 and 6	RR	40	–	–	dB
ON	notes 5 and 7	RR	45	–	–	dB
mute	notes 5 and 8	RR	45	–	–	dB
stand-by	notes 5 and 8	RR	80	–	–	dB
Input impedance		$ Z_i $	50	60	75	$\text{k}\Omega$
Noise output voltage (RMS value)	note 9					
ON	$R_S = 0\ \Omega$	$V_{no(rms)}$	–	150	–	μV
ON	$R_S = 10\ \text{k}\Omega$	$V_{no(rms)}$	–	250	500	μV
mute	note 10	$V_{no(rms)}$	–	120	–	μV
Channel separation	$R_S = 10\ \text{k}\Omega$	α	40	–	–	dB
Channel unbalance		$ \Delta G_v $	–	0.1	1	dB

22 W BTL or 2 x 11 W stereo car radio power amplifier

TDA1519A

AC CHARACTERISTICS

$V_P = 14.4\text{ V}$; $R_L = 4\ \Omega$; $f = 1\text{ kHz}$; $T_{\text{amb}} = 25\text{ }^\circ\text{C}$; measurements taken using Fig.4; unless otherwise specified

PARAMETER	CONDITIONS	SYMBOL	MIN.	TYP.	MAX.	UNIT
BTL application						
Output power	note 3					
	THD = 0.5%	P_o	15	17	–	W
	THD = 10%	P_o	20	22	–	W
Output power at $V_P = 13.2\text{ V}$	note 3					
	THD = 0.5%	P_o	–	13	–	W
	THD = 10%	P_o	–	17.5	–	W
Total harmonic distortion	$P_o = 1\text{ W}$	THD	–	0.1	–	%
Power bandwidth	THD = 0.5%; $P_o = -1\text{ dB}$; w.r.t. 15 W	B_w	–	35 to 15 000	–	Hz
Low frequency roll-off	note 4					
	-1 dB	f_L	–	45	–	Hz
High frequency roll-off	-1 dB	f_H	20	–	–	kHz
Closed loop voltage gain		G_v	45	46	47	dB
Supply voltage ripple rejection						
ON	notes 5 and 6	RR	34	–	–	dB
ON	notes 5 and 7	RR	48	–	–	dB
mute	notes 5 and 8	RR	48	–	–	dB
stand-by	notes 5 and 8	RR	80	–	–	dB
Input impedance		$ Z_i $	25	30	38	k Ω
Noise output voltage (RMS value)	note 9					
ON	$R_S = 0\ \Omega$	$V_{\text{no(rms)}}$	–	200	–	μV
ON	$R_S = 10\text{ k}\Omega$	$V_{\text{no(rms)}}$	–	350	700	μV
mute	note 10	$V_{\text{no(rms)}}$	–	180	–	μV

Notes to the characteristics

- The circuit is DC adjusted at $V_P = 6\text{ V}$ to 17.5 V and AC operating at $V_P = 8.5\text{ V}$ to 17.5 V .
- At $17.5\text{ V} < V_P < 30\text{ V}$ the DC output voltage $\leq V_P/2$.
- Output power is measured directly at the output pins of the IC.
- Frequency response externally fixed.
- Ripple rejection measured at the output with a source impedance of $0\ \Omega$ (maximum ripple amplitude of 2 V).
- Frequency $f = 100\text{ Hz}$.
- Frequency between 1 kHz and 10 kHz .
- Frequency between 100 Hz and 10 kHz .
- Noise voltage measured in a bandwidth of 20 Hz to 20 kHz .
- Noise output voltage independent of R_S ($V_i = 0\text{ V}$).

22 W BTL or 2 x 11 W stereo car radio
power amplifier

TDA1519A

APPLICATION INFORMATION

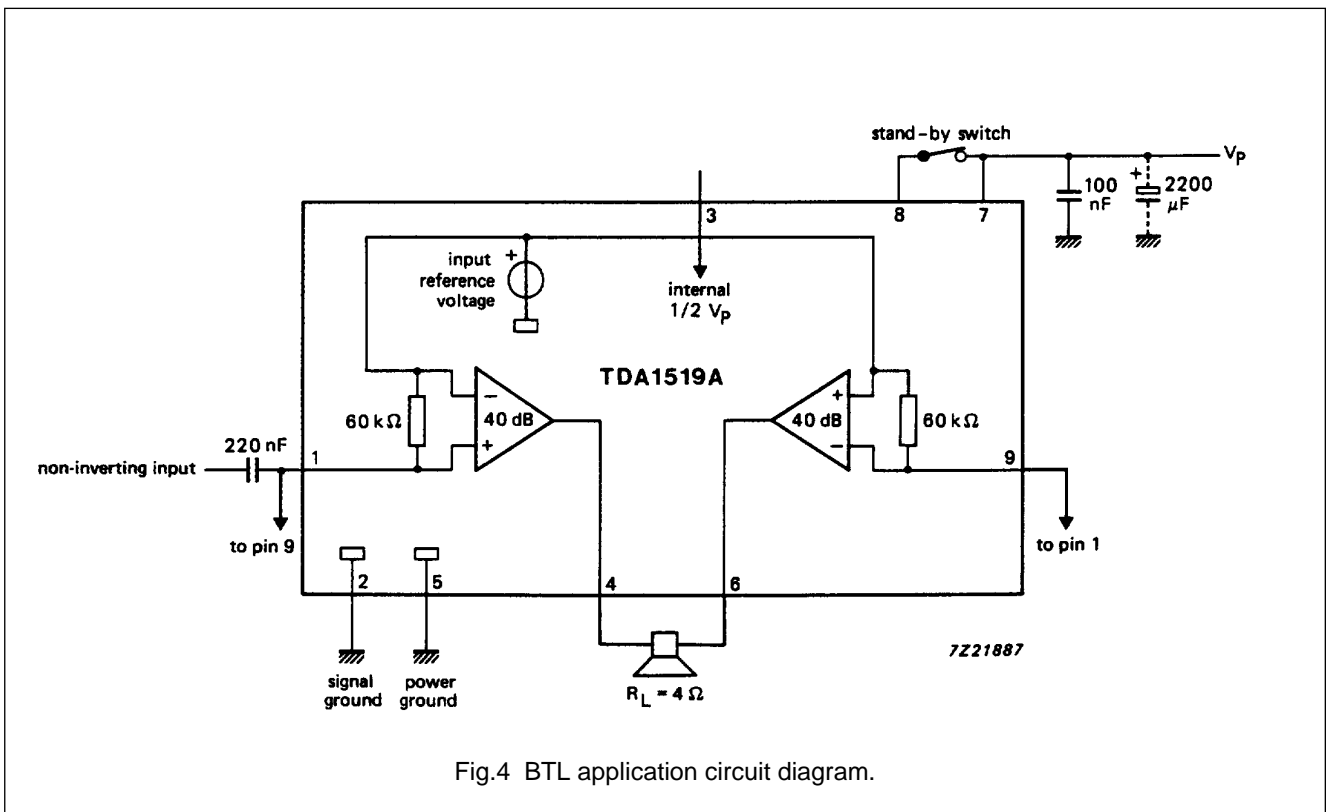
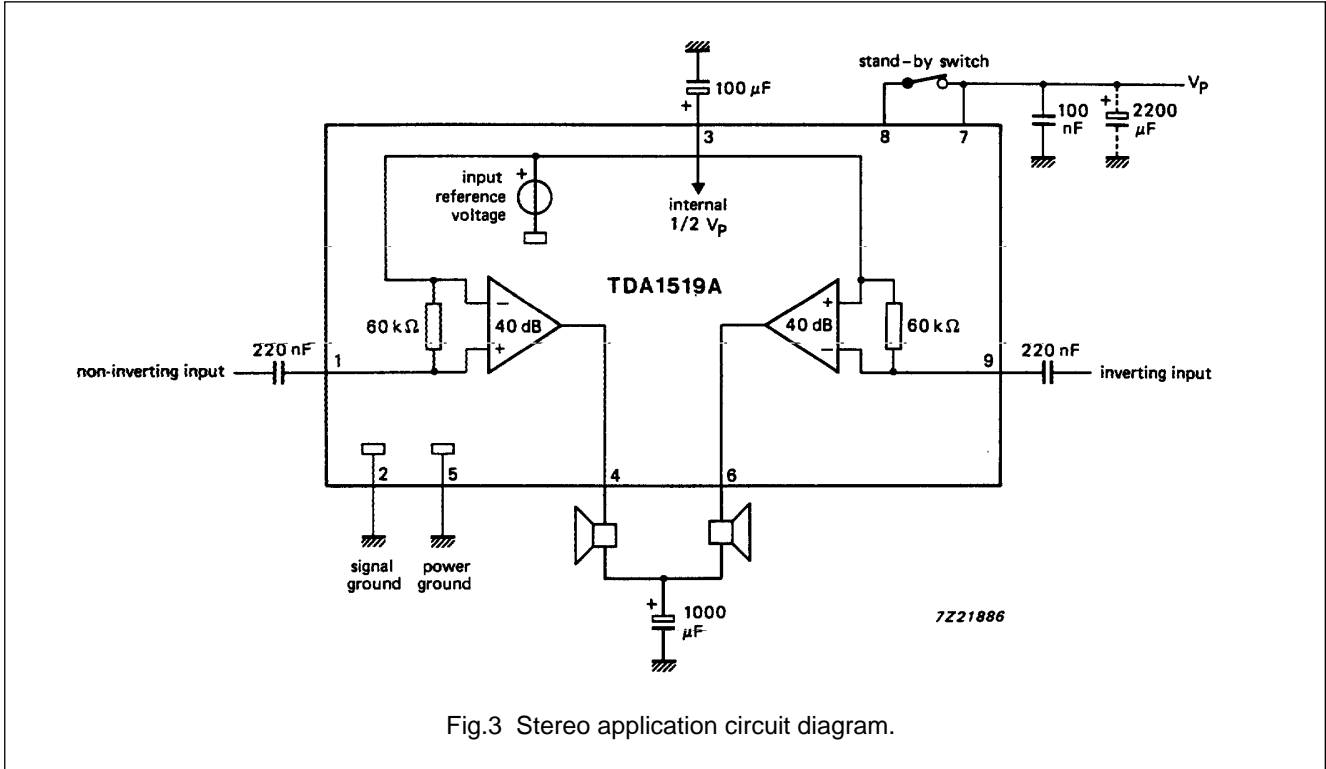

22 W BTL or 2 x 11 W stereo car radio
power amplifier

TDA1519A

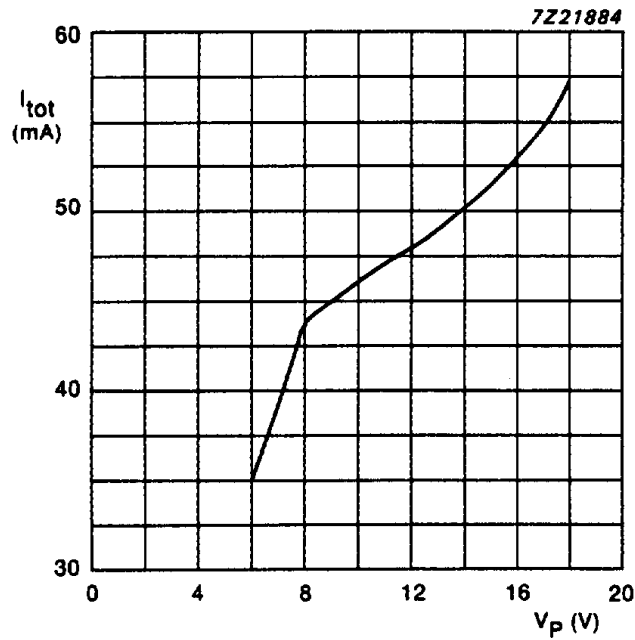

Fig.5 Total quiescent current (I_{tot}) as a function of supply voltage (V_P).

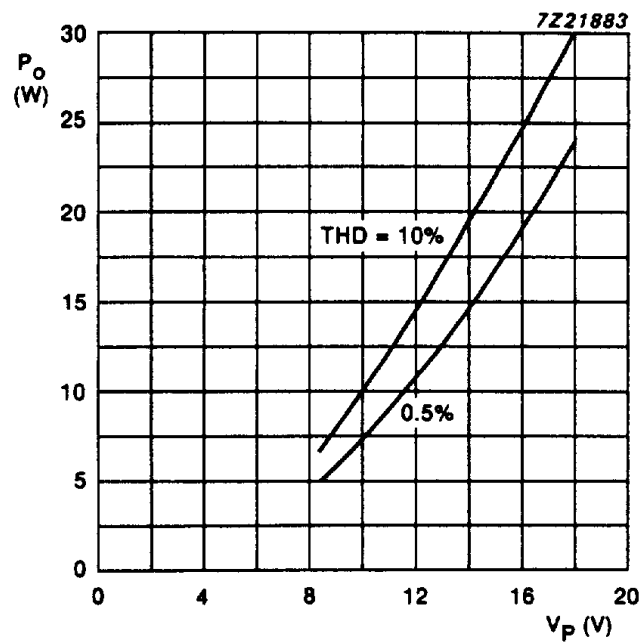

Fig.6 Output power (P_o) as a function of supply voltage (V_P) for BTL application at $R_L = 4 \Omega$; $f = 1 \text{ kHz}$.

22 W BTL or 2 x 11 W stereo car radio
power amplifier

TDA1519A

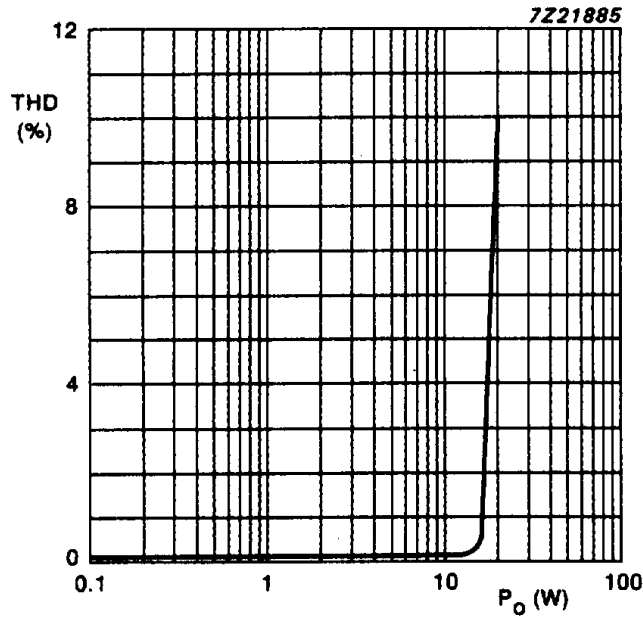

Fig.7 Total harmonic distortion (THD) as a function of output power (P_o) for BTL application at $R_L = 4 \Omega$; $f = 1 \text{ kHz}$.

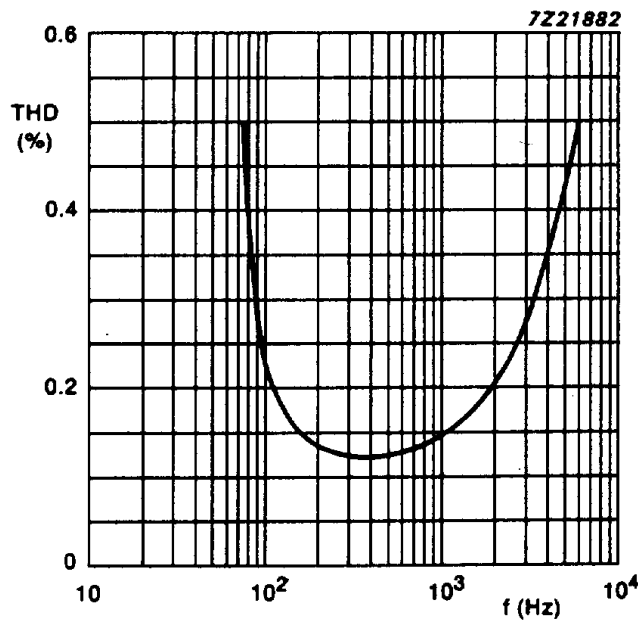

Fig.8 Total harmonic distortion (THD) as a function of operating frequency (f) for BTL application at $R_L = 4 \Omega$; $P_o = 1 \text{ W}$.

22 W BTL or 2 x 11 W stereo car radio
power amplifier

TDA1519A

PACKAGE OUTLINES

SIL9P: plastic single in-line power package; 9 leads

SOT131-2

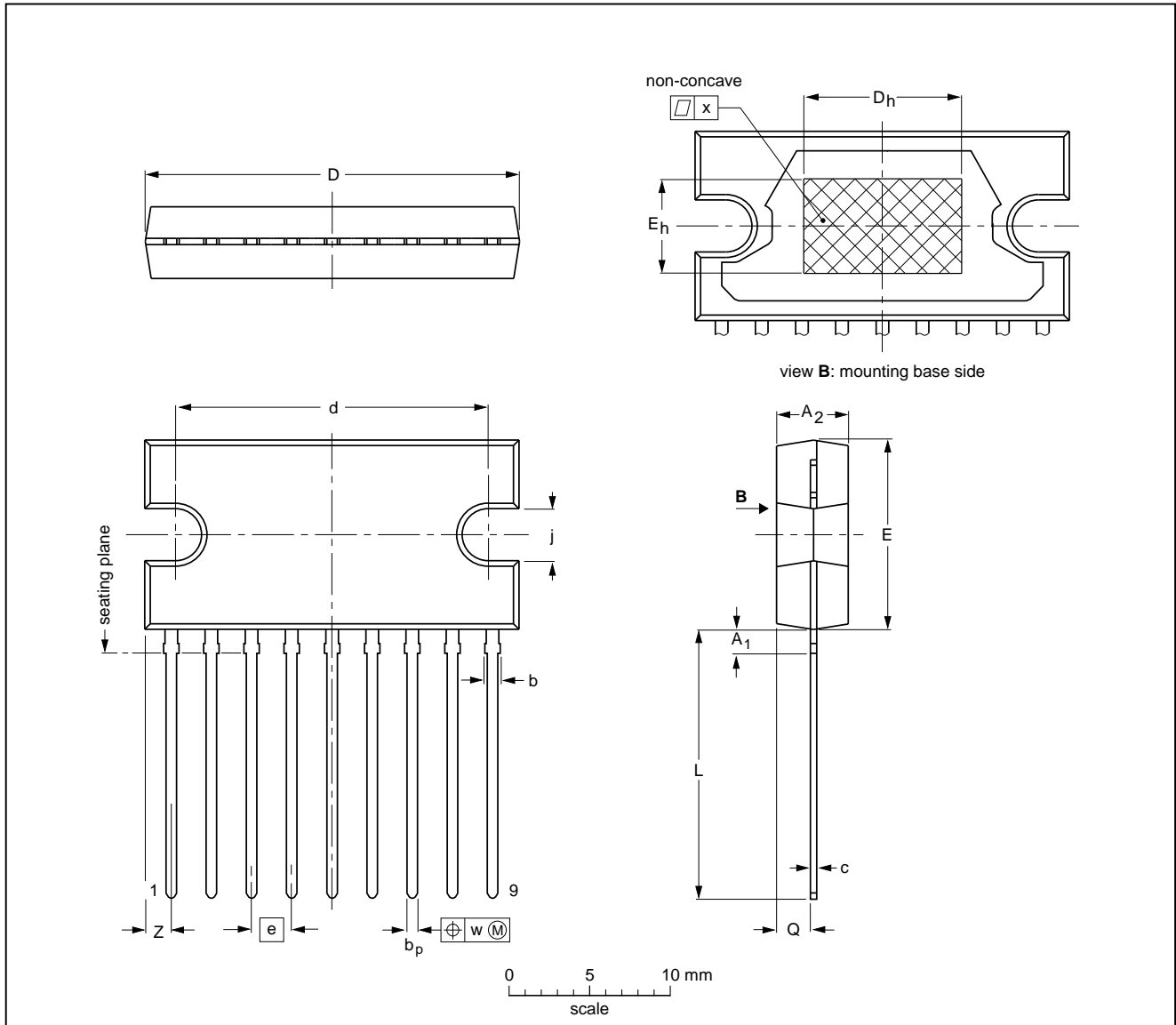

DIMENSIONS (mm are the original dimensions)

UNIT	A ₁ max.	A ₂	b max.	b _p	c	D ⁽¹⁾	d	D _h	E ⁽¹⁾	e	E _h	j	L	Q	w	x	Z ⁽¹⁾
mm	2.0	4.6 4.2	1.1	0.75 0.60	0.48 0.38	24.0 23.6	20.0 19.6	10	12.2 11.8	2.54	6	3.4 3.1	17.2 16.5	2.1 1.8	0.25	0.03	2.00 1.45

Note

1. Plastic or metal protrusions of 0.25 mm maximum per side are not included.

OUTLINE VERSION	REFERENCES				EUROPEAN PROJECTION	ISSUE DATE
	IEC	JEDEC	EIAJ			
SOT131-2						92-11-17 95-03-11

22 W BTL or 2 x 11 W stereo car radio
power amplifier

TDA1519A

DBS9P: plastic DIL-bent-SIL power package; 9 leads (lead length 12 mm)

SOT157-2

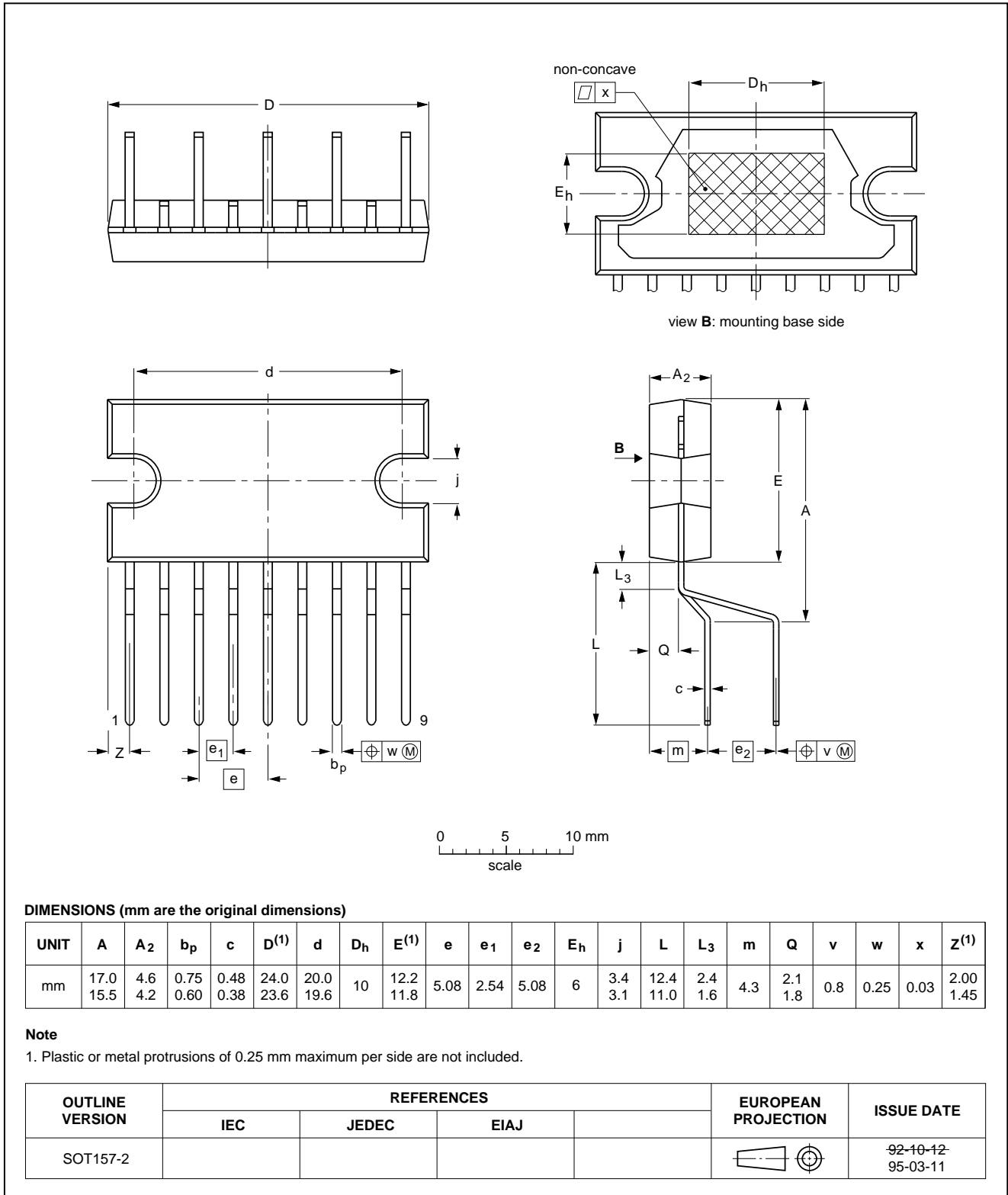

22 W BTL or 2 x 11 W stereo car radio power amplifier

TDA1519A

SOLDERING

Introduction

There is no soldering method that is ideal for all IC packages. Wave soldering is often preferred when through-hole and surface mounted components are mixed on one printed-circuit board. However, wave soldering is not always suitable for surface mounted ICs, or for printed-circuits with high population densities. In these situations reflow soldering is often used.

This text gives a very brief insight to a complex technology. A more in-depth account of soldering ICs can be found in our "IC Package Databook" (order code 9398 652 90011).

Soldering by dipping or by wave

The maximum permissible temperature of the solder is 260 °C; solder at this temperature must not be in contact with the joint for more than 5 seconds. The total contact time of successive solder waves must not exceed 5 seconds.

The device may be mounted up to the seating plane, but the temperature of the plastic body must not exceed the specified maximum storage temperature ($T_{stg\ max}$). If the printed-circuit board has been pre-heated, forced cooling may be necessary immediately after soldering to keep the temperature within the permissible limit.

Repairing soldered joints

Apply a low voltage soldering iron (less than 24 V) to the lead(s) of the package, below the seating plane or not more than 2 mm above it. If the temperature of the soldering iron bit is less than 300 °C it may remain in contact for up to 10 seconds. If the bit temperature is between 300 and 400 °C, contact may be up to 5 seconds.

DEFINITIONS

Data sheet status	
Objective specification	This data sheet contains target or goal specifications for product development.
Preliminary specification	This data sheet contains preliminary data; supplementary data may be published later.
Product specification	This data sheet contains final product specifications.
Limiting values	
Limiting values given are in accordance with the Absolute Maximum Rating System (IEC 134). Stress above one or more of the limiting values may cause permanent damage to the device. These are stress ratings only and operation of the device at these or at any other conditions above those given in the Characteristics sections of the specification is not implied. Exposure to limiting values for extended periods may affect device reliability.	
Application information	
Where application information is given, it is advisory and does not form part of the specification.	

LIFE SUPPORT APPLICATIONS

These products are not designed for use in life support appliances, devices, or systems where malfunction of these products can reasonably be expected to result in personal injury. Philips customers using or selling these products for use in such applications do so at their own risk and agree to fully indemnify Philips for any damages resulting from such improper use or sale.