

9097247 TOSHIBA, ELECTRONIC

02E 17479 D

TA7658P

T-77-21

DUAL PREAMPLIFIER FOR TAPE RECORDER

The TA7658P is a dual preamplifier with ALC (Automatic Level Control) designed for use in a record/playback amplifier of tape recorder. It is suitable for a stereo set and a radio-cassette recorder.

- DIP 14 PIN (Dual In-Line Package)
- Built-in Buffer Amplifier (It permits meter drive and ALC to be easily performed)
- No Input Coupling Capacitor
- Quick Stabilization at Power ON.
- Wide Supply Voltage Range: $V_{CC}=3\sim 16V$

Unit in mm

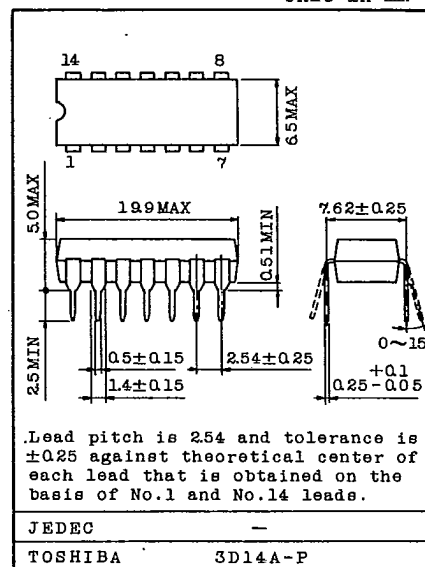

Lead pitch is 2.54 and tolerance is ± 0.25 against theoretical center of each lead that is obtained on the basis of No.1 and No.14 leads.

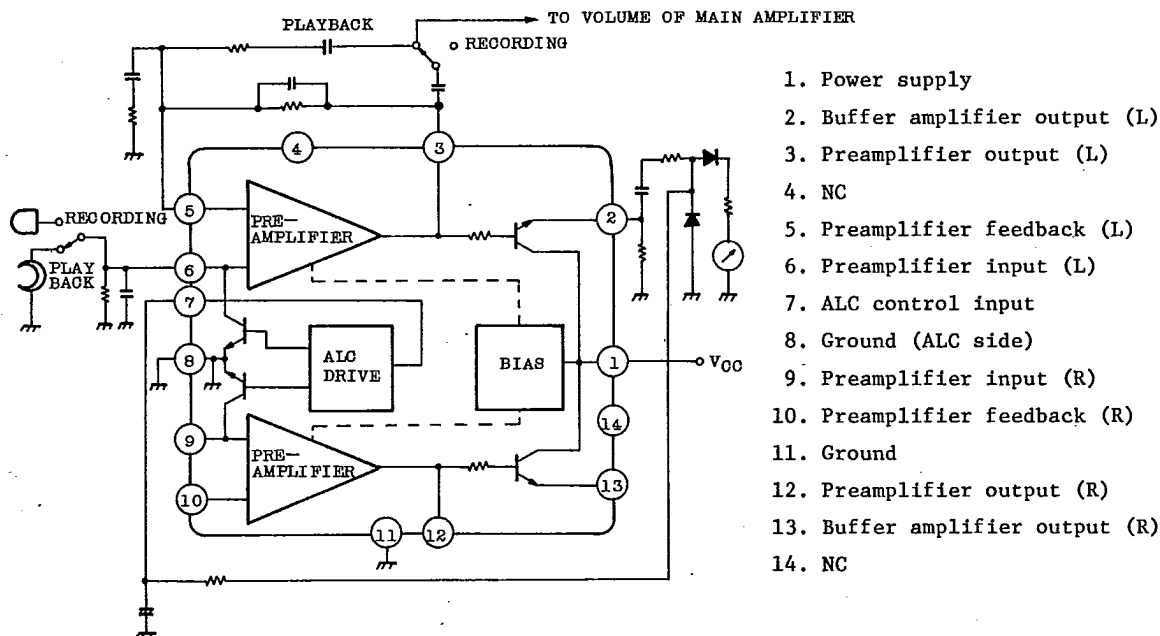
BLOCK DIAGRAM**TOSHIBA**

TA7658P

MAXIMUM RATINGS (Ta=25°C)

CHARACTERISTIC	SYMBOL	RATING	UNIT
Supply Voltage	V _{CC}	16	V
Output Current (Buffer amplifier Pin 2, Pin 13)	I ₂ , I ₁₃	3	mA
Output Current (Preamplifier Pin 6, Pin 9)	I ₆ , I ₉	2	mA
Power Dissipation (Note)	P _D	625	mW
Operating Temperature	T _{opr}	-25 ~ 75	°C
Storage Temperature	T _{stg}	-55 ~ 150	°C

Note: Derated above Ta=25°C in the proportion of 5mW/°C.

ELECTRICAL CHARACTERISTICS

(Unless otherwise specified Ta=25°C, V_{CC}=5V, f=1kHz)

CHARACTERISTIC	SYMBOL	TEST CIR-CUIT	TEST CONDITION	MIN.	TYP.	MAX.	UNIT
Quiescent Current	I _{CCQ}	1	-	6	10	15	mA
Input Terminal DC Voltage	V ₆ , V ₉	1	-	-	15	50	mV
Output Terminal DC Voltage	V ₃ , V ₁₂	1	-	2.2	2.5	2.8	V
Buffer Output DC Voltage	V ₂ , V ₁₃	1	-	1.4	1.6	2	V
ALC Bias Voltage	V ₇	1	-	0.4	0.55	0.7	V
ALC ON Voltage	V _{IN} (ALC)	1	V ₇ =1.4V	-	5	30	mV
ALC Range	R _{ALC}	2	V _{IN} =-60dBm	35	40	-	dB
ALC Level	V _{OUT} (ALC)	2	V _{IN} =-20dBm	-3	-1	1	dBm
Total Harmonic Distortion (ALC)	THD(ALC)	2	V _{IN} =-20dBm	-	0.6	2	%
ALC Balance	B _{ALC}	2	-	-	0	2	dB
Max. Output Voltage	V _{OM}	2	THD=1%	1.3	1.7	-	V _{rms}
Channel Crosstalk	CT	2	R _g =2.2kΩ, V _{OUT} =0dBm	40	50	-	dB
Open Loop Voltage Gain	G _{VO}	2	V _{IN} =-80dBm	67	75	-	dB
Equivalent Input Noise Voltage	V _{NI}	2	R _g =2.2kΩ	-	1.3	2.7	μV _{rms}

AUDIO LINEAR IC

TA7658P

TEST CIRCUIT 1

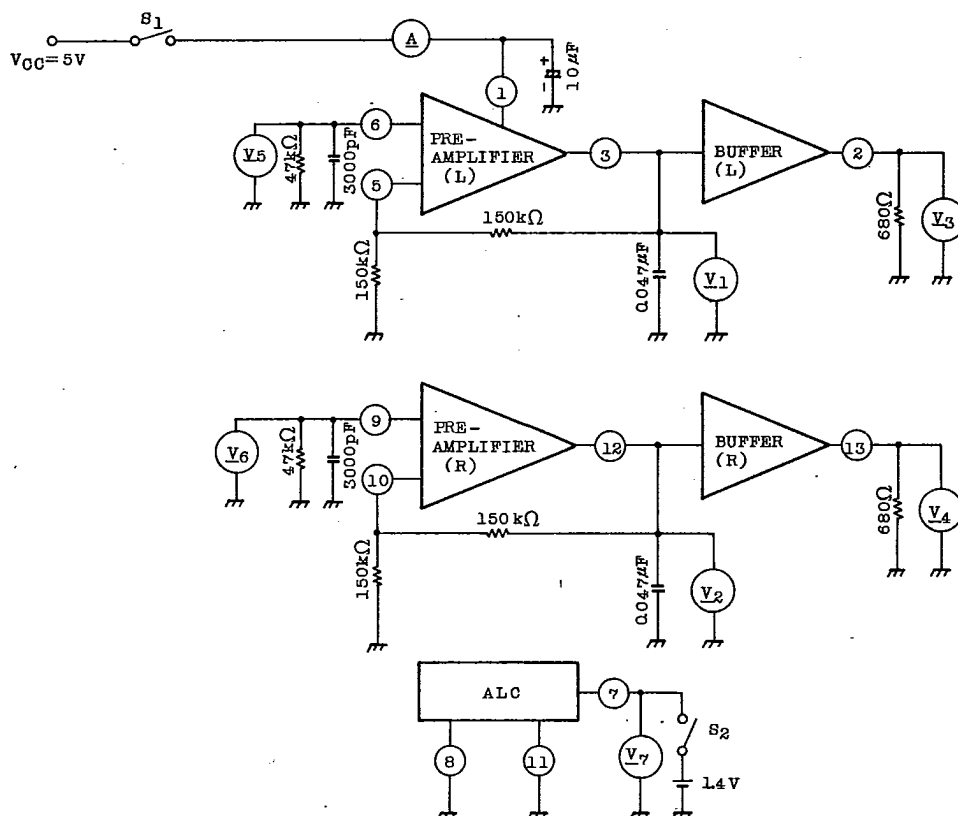

TEST METHOD

SYMBOL	S ₁	S ₂	TEST POINT	TEST PROCEDURE
I _{CCQ}	ON	OFF	A	Read ammeter
V ₆ , V ₉	ON	OFF	V ₅ , V ₆	Read voltmeter
V ₃ , V ₁₂	ON	OFF	V ₁ , V ₂	Read voltmeter
V ₂ , V ₁₃	ON	OFF	V ₃ , V ₄	Read voltmeter
V ₇	ON	OFF	V ₇	Read voltmeter
V _{IN(ALC)}	ON	ON	V ₅ , V ₆	Measure the voltage on pin 6 and pin 9 when 1.4V is applied to pin 7

TOSHIBA

TA7658P

TEST CIRCUIT 2

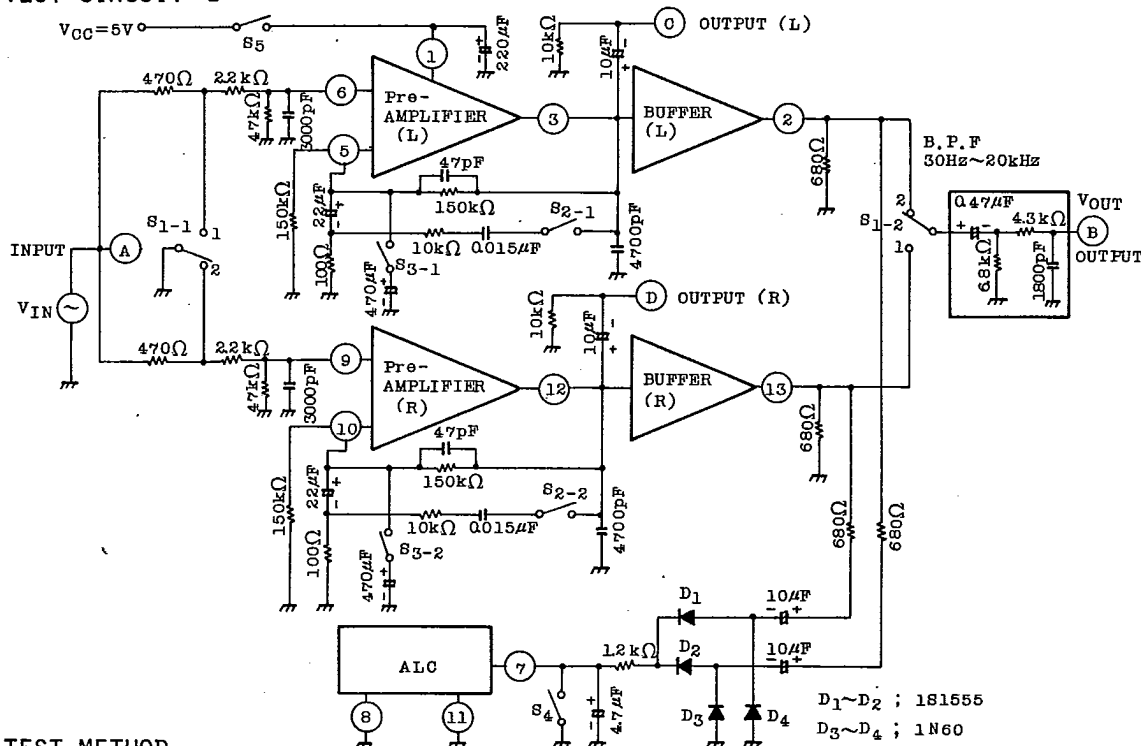

TEST METHOD

SYMBOL	S1		S2	S3	S4	S5	TEST POINTS	TEST PROCEDURE
	L	R						
GVO	1	2	OFF	ON	ON	ON	A, C, D	GVO is obtained by $GVO = 20 \log V_{OUT}/V_{IN}$ (dB). If input voltage is V_{IN} and output voltage is V_{OUT}
$V_{OUT}(ALC)$	1	2	OFF	OFF	OFF	ON	B	Output voltage V_{OUT} is measured with a VTVM when input voltage $V_{IN} = -20dBm$ is applied.
THD(ALC)	1	2	OFF	OFF	OFF	ON	B	Output voltage V_{OUT} is measured with a distortion meter when input voltage $V_{IN} = -20dB$ is applied.
VNI	S1-1=1 S1-2=2	S1-1=2 S1-2=2	ON	OFF	ON	ON	B	Output voltage V_{OUT} at $R_g = 2.2k\Omega$ is measured with a VTVM, and is converted by the gain of 1kHz.
VOM	1	2	ON	OFF	ON	ON	C, D	Measure output voltage V_{OUT} at total harmonic distortion THD=1% is measured with a VTVM.
CT	1	2	ON	OFF	ON	ON	B	Crosstalk between(L) and (R) at output voltage $V_{OUT} = 0dBm$ is measured.
RALC	1	2	OFF	OFF	OFF	ON	B	Input voltage range from $V_{IN} = -60dBm$ to output voltage V_{OUT} 3dB UP.
BALC	1	2	OFF	OFF	OFF	ON	B	Level difference between output voltages V_{OUT} (L) and (R) at the time when input voltage $V_{IN} = -20dBm$ is applied.

AUDIO LINEAR IC

TA7658P

EQUIVALENT CIRCUIT

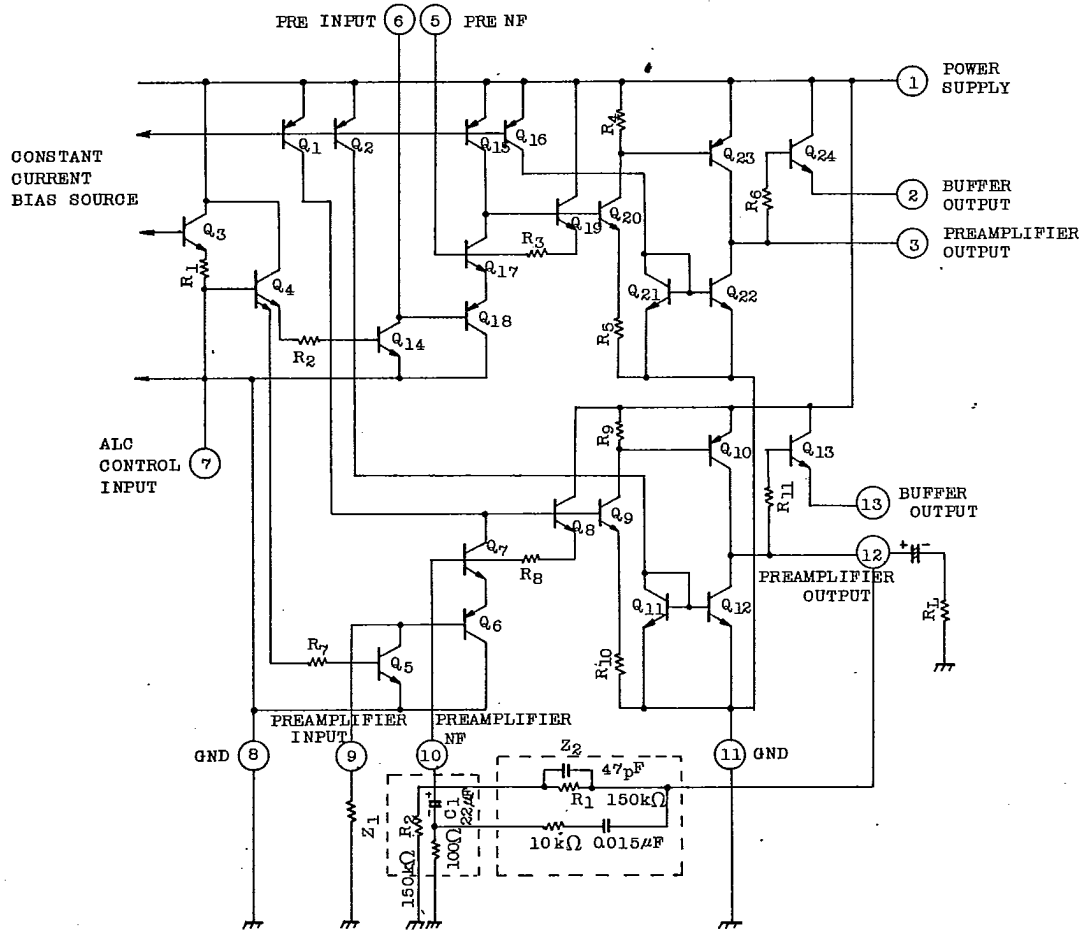

TOSHIBA

TA7658P

DESCRIPTION OF EQUIVALENT CIRCUIT

1) BIAS CIRCUIT

The constant current circuit formed by Q₁ and Q₂ is connected to the constant current bias source composed of being free from power supply variation for the purpose of obtaining a bias source of higher power supply ripple suppression ratio. Therefore, the operating current of the first stage transistor Q₆ is not affected by the power supply variation, and the ripple suppression ratio shows a good characteristic since the operating electric potential of the first stage (Q₇ collector) is stabilized, thus requiring no decoupling at the first stage.

2) AMPLIFIER

The first stage is a complimentary differential stage of Q₆ and Q₇, the input terminal voltage (Q₆ base) is about "0"V, and the playback head can be directly coupled without a chemical capacitor.

Q₁ not only sets the first stage current, but also functions as an active load. The medium stage Q₉ is approximately a phase inverter and level shift stage for the gain 1. The output stage Q₁₀ is the emitter ground stage changing Q₁₂ to an active load. The current is defined by Q₁₁ and Q₁₂ as $I(Q_{10}) \approx 1.6\text{mA}$.

At the back of the output stage, the emitter follower Q₁₃ is directly coupled in IC for buffering. Q₁₃ is an open emitter, and the operating current can be arbitrarily selected by an external resistor.

3) ALC CIRCUIT

The transistor Q₅ for ALC (Automatic Level Control) is DC-coupled to the input terminal. Therefore, Q₆ bias resistor is connected in parallel between the collector and emitter of Q₅. ALC control terminal ⑦ (Q₄ base) is DC-biased in about 0.55V by Q₃. Consequently, attack time can be shortened since the smoothing capacitor for ALC has been biased in 0.05V from the beginning.

4) VOLTAGE GAIN

◦ Open Loop Voltage Gain G_{V0} (1kHz) in Amplifier

$$G_{V0}(1\text{kHz}) = \frac{1}{2r_e(Q_6) \cdot R_{10}} \times h_{FE}(Q_{10}) \times R_L \text{ is obtained.}$$

AUDIO LINEAR IC

TA7658P

$$\left. \begin{array}{l} \text{IF } \frac{1}{h_{oe}(Q_1)} = 50k\Omega \\ h_{FE}(Q_{10}) = 20 \\ R_L = 10k\Omega \\ 2r_e(Q_6) = 1k\Omega \\ R_{10} = 1.8k\Omega \end{array} \right\} \begin{array}{l} \text{is given, } G_{V0} \approx 5.5 \times 10^3 = 74.9\text{dB} \\ \text{is realized.} \end{array}$$

$$\left(\begin{array}{l} \frac{1}{h_{oe}(Q_1)} \dots\dots Q_1 \text{ output impedance} \\ 2r_e(Q_6) \dots\dots Q_6 \text{ emitter junction resistance} \end{array} \right)$$

o Close Loop Voltage Gain $G_V(1\text{kHz})$

$$G_V(1\text{kHz}) = \frac{G_{V0}}{1 + \beta \cdot G_{V0}} \dots\dots (1) \quad (\beta = \text{Feedback ratio})$$

$$\beta = \frac{Z_1}{Z_1 + Z_2} \dots\dots (2) \quad \text{is made.}$$

$$\left. \begin{array}{l} \text{If } G_{V0} = 75\text{dB} \\ Z_1 = 100\Omega \\ Z_2 = 13.3k\Omega \end{array} \right\} \begin{array}{l} \text{are given, put the equation (1) into} \\ \text{the equation (2),} \end{array}$$

$$G_V(1\text{kHz}) = 1.32 \times 10^2 = 42.4\text{dB} \text{ is obtained.}$$

o Selection of External Resistors R_1 and R_2

R_1 and R_2 in the internal equivalent circuit should be appropriately selected to obtain output as much as possible. Output terminals (L) = pin 3 and (R) = pin 12 can obtain the maximum output at the time of $1/2 V_{CC}$. Therefore, the values of R_1 and R_2 may be selected according to the following equations.

$$V_{12}(V_3) = \frac{V_{CC}}{2} = \frac{R_1 + R_2}{R_2} \times V_{10}(V_5) \quad V_{10}(V_5) = 1.1 \sim 1.2\text{V}$$

L channel is shown in (V3).

Graph "V_{OM}, R₂-V_{CC}" shows the relation between V_{CC} and the maximum output at the time when R₁=150k Ω as parameter R₂. The value of R₂ should be selected by taking the characteristics at decreasing voltage into due consideration.

TA7658P

5) ALC ATTACK TIME AND RECOVERY TIME SETTING

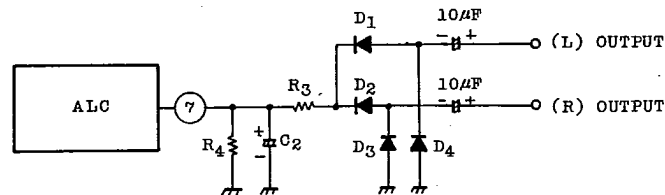

The attack time from the application of the input signal to the starting of ALC can be adjusted by the time constants of R_3 and C_2 , while the recovery time from no application of the input signal to the restoration of amplifier gain can be adjusted by the time constants of R_4 and C_2 . In addition, silicon diode should be used for D_1 and D_2 , while germanium diode for D_3 and D_4 . A capacitor of $47\mu\text{F}$ or more should be used for C_2 .

TA7658P

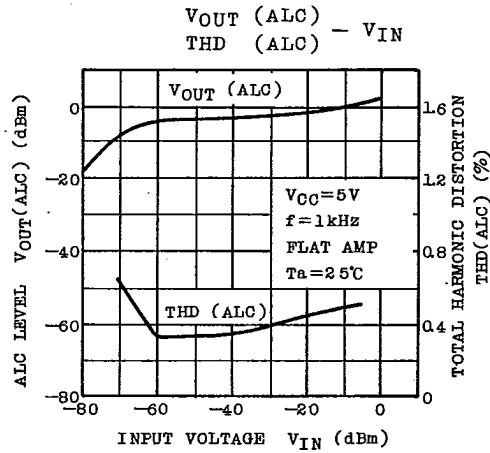
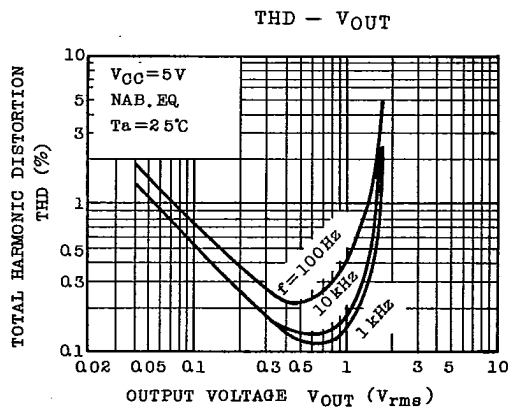
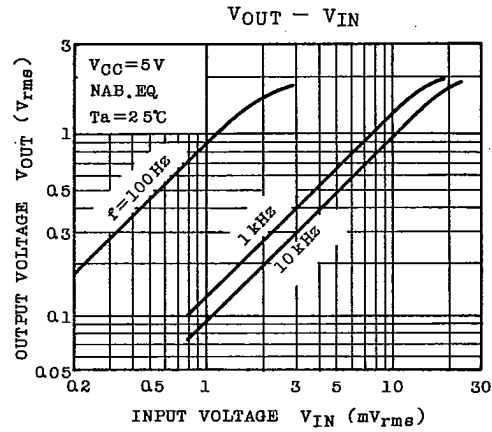
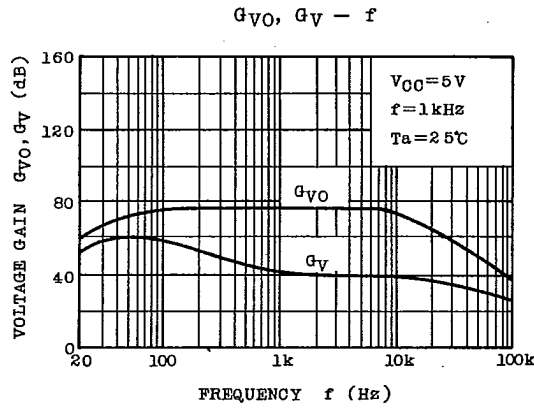

TA7658P

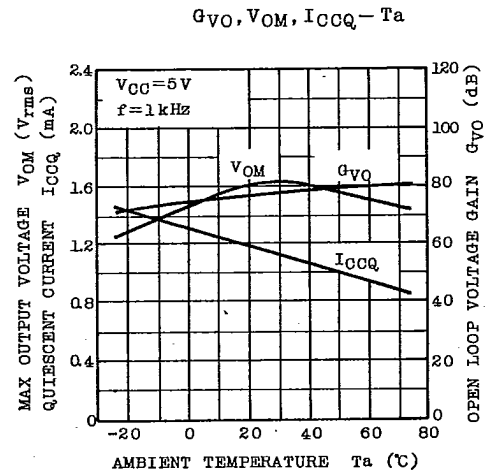
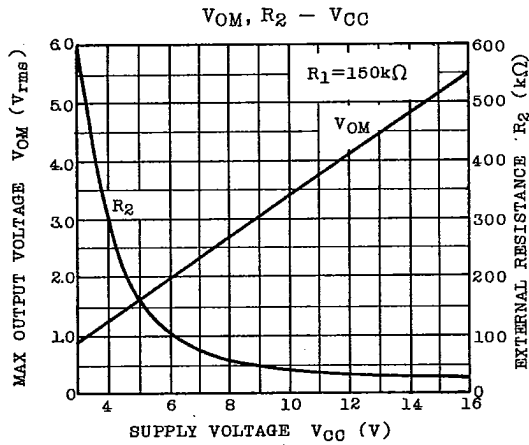
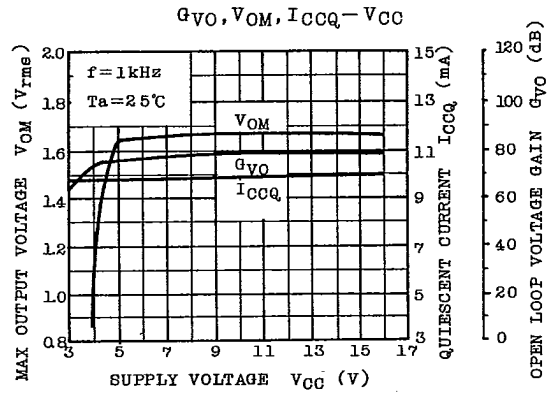
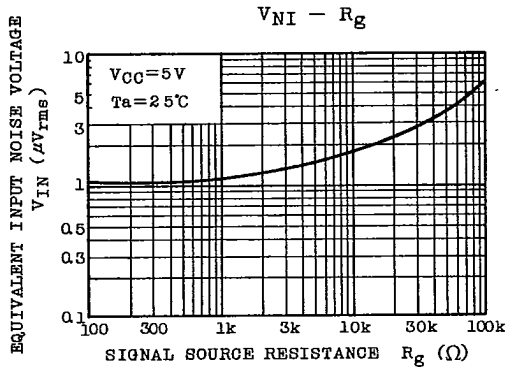

AUDIO LINEAR IC

TA7658P

APPLICATION CIRCUIT (REC/P.B)

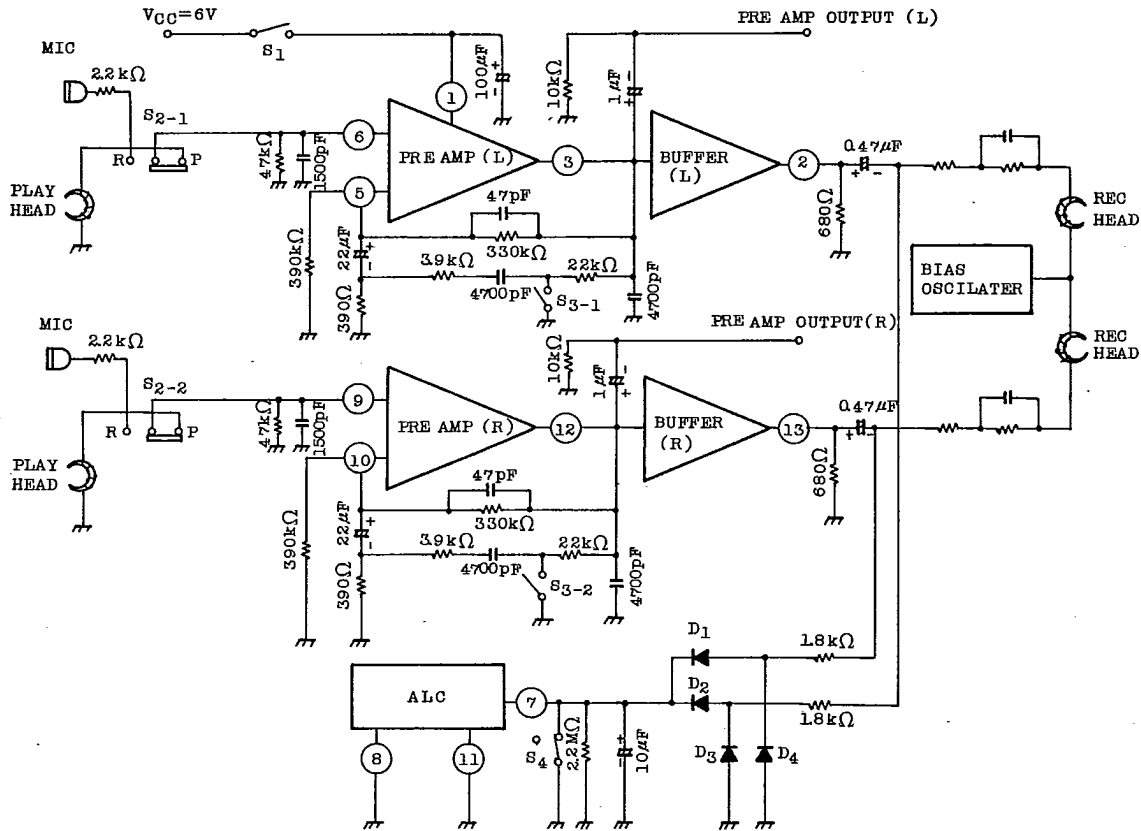

Each switch position is playback.

D1~D2 : 1S155 or Equivalent

D3~D4 : 1N60 or Equivalent

TOSHIBA

TA7658P

DATA OF APPLICATION CIRCUIT

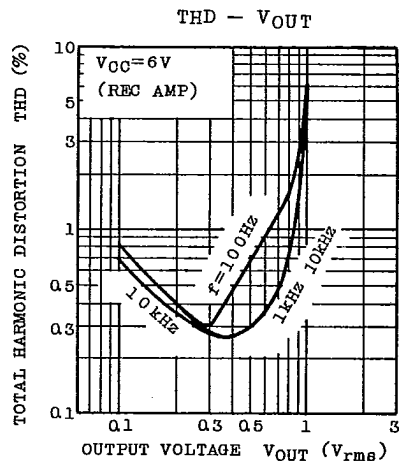
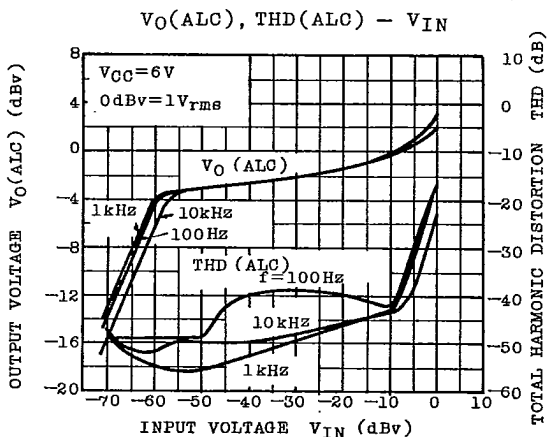
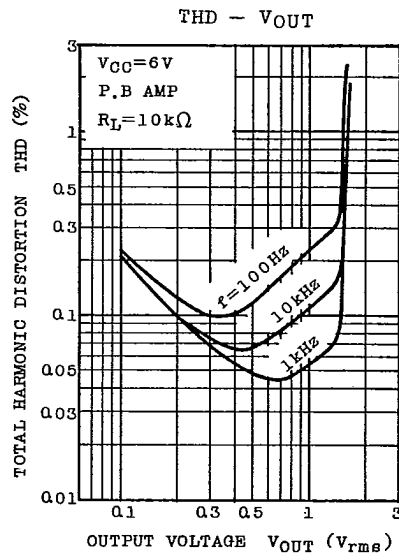
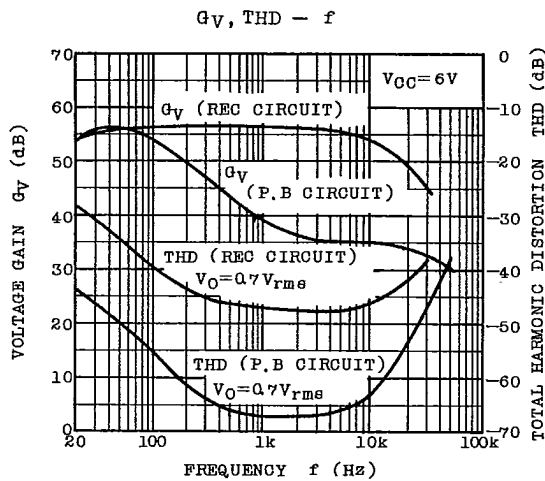

AUDIO LINEAR IC