

## Features

- Carbon element
- Ganging up to 8 sections available
- Knurled and flatted shaft styles
- Audio taper option
- Tracking error within 3 dB
- RoHS compliant\*

## Applications

- Audio/TV sets
- Automotive sound systems
- Amplifiers/mixers/drum machines/synthesizers/DJ equipment
- Multimedia sound systems
- Portable electronics

# PTR90 Series - 9 mm Multi-Ganged Potentiometer w/Rotary Switch

### Electrical Characteristics

Standard Resistance Range .....1 K ohms to 1 M ohms  
 Total Resistance Tolerance .....±10 % or ±20 %  
 Standard Tapers.....Linear & audio  
 Maximum Operating Voltage .....150 VAC, 20 VDC  
 Rated Power  
 Linear Taper .....0.05 watts  
 Audio Taper.....0.025 watts  
 Noise .....100 mV max.  
 Insulation Resistance @ 250 VDC .....100 M ohms  
 Dielectric Withstanding Voltage .....300 VAC  
 End Resistance .....20 ohms max.  
 Tracking Error (-40 dB to 0 dB) .....±3 dB

### Environmental Characteristics

Operating Temperature .....-10 °C to +50 °C  
 Rotational Life .....10,000 cycles  
 IP Rating .....IP 40

### Switch Characteristics

Contact Resistance ....50 milliohms max.  
 Rated Power.....3 A @ 16 VDC  
 Detent Torque .....400 g-cm max.  
 Switch Activation Angle.....50 ° max.

### Mechanical Characteristics

Mechanical Angle .....300 ° ±10 °  
 Running Torque .....10 to 250 g-cm  
 Stop Strength .....4.0 kg-cm  
 Shaft Push/Pull Strength .....5.0 kgf min.  
 Shaft Wobble ....0.6 x L/20 mm p-p max.  
 Mounting Torque.....7.0 kg-cm min.  
 Soldering Condition  
 Manual Soldering  
 .....96.5 Sn/3.0 Ag/0.5 Cu solid wire  
 or no-clean rosin cored wire  
 270 °C max. for 3 seconds  
 Wave Soldering  
 .....96.5 Sn/3.0 Ag/0.5 Cu solder  
 with no-clean flux  
 260 °C max. for 5 seconds  
 Wash Process .....Not recommended  
 Mounting Hardware .....One flat washer  
 and one mounting nut supplied  
 per potentiometer

### Product Dimensions

PTR901

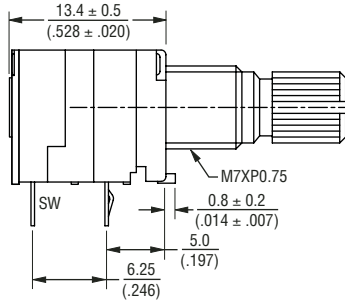

RECOMMENDED PCB LAYOUT

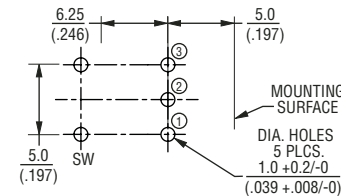

SCHEMATIC

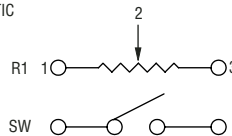

PTR902

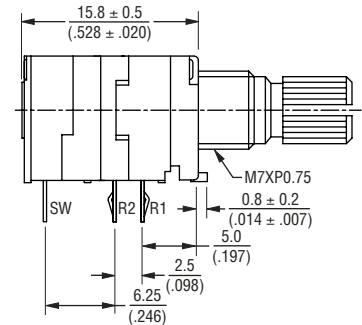

RECOMMENDED PCB LAYOUT

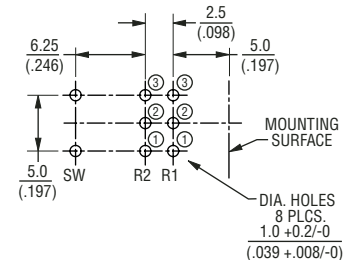

SCHEMATIC

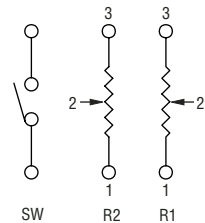

DIMENSIONS ARE:  $\frac{\text{MM}}{\text{(INCHES)}}$

\*RoHS Directive 2002/95/EC Jan 27 2003 including Annex  
 Specifications are subject to change without notice.  
 Customers should verify actual device performance in their specific applications.

# PTR90 Series - 9 mm Multi-Ganged Potentiometer w/Rotary Switch

**BOURNS®**

## Product Dimensions

**PTR904**

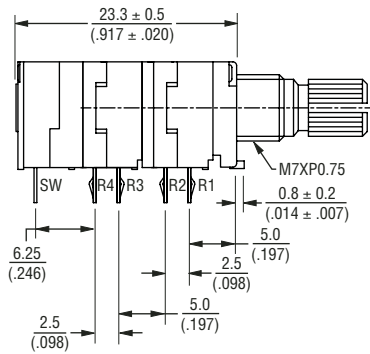

**PTR906**

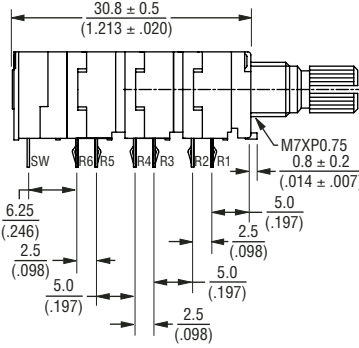

**PTR908**

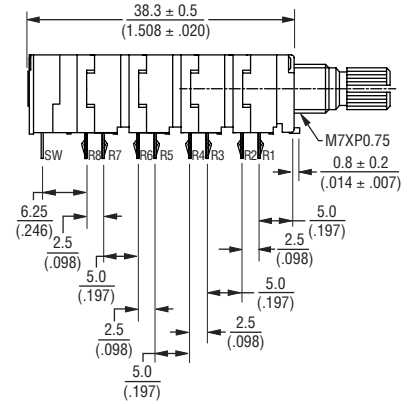

RECOMMENDED PCB LAYOUT

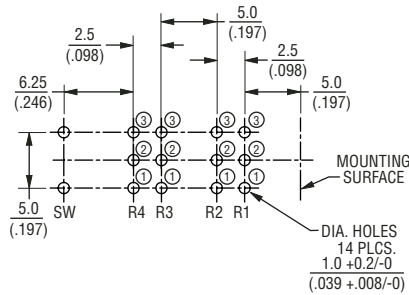

RECOMMENDED PCB LAYOUT

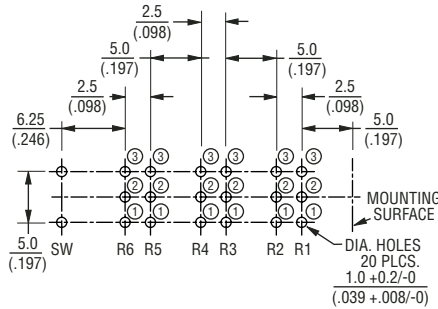

RECOMMENDED PCB LAYOUT

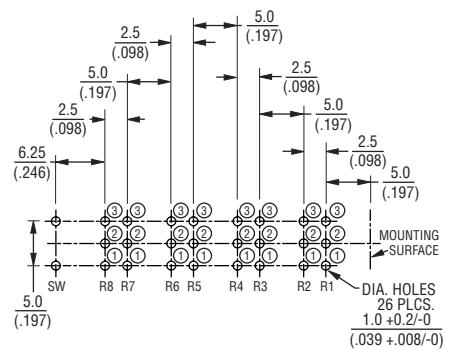

SCHEMATIC

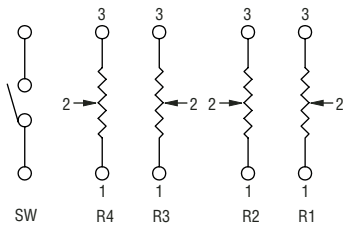

SCHEMATIC

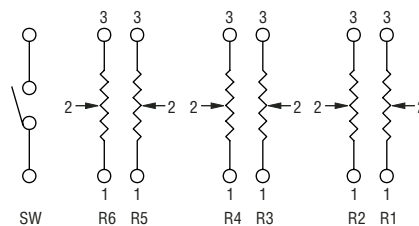

SCHEMATIC

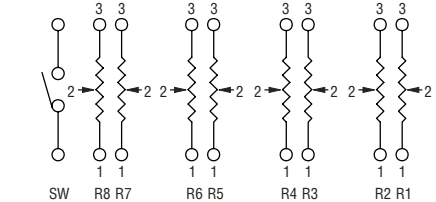

DIMENSIONS ARE:  $\frac{\text{MM}}{\text{(INCHES)}}$

Specifications are subject to change without notice. Customers should verify actual device performance in their specific applications.

# PTR90 Series - 9 mm Multi-Ganged Potentiometer w/Rotary Switch



## Product Dimensions

### SHAFT STYLE "K"

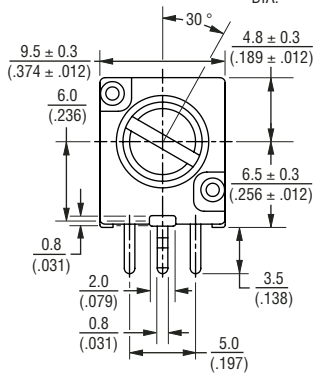
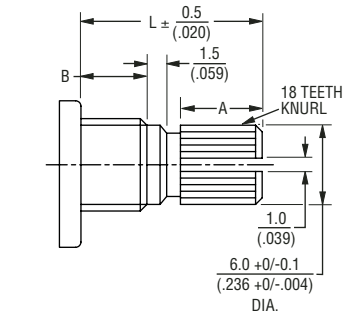

SHAFT SHOWN IN CCW POSITION

L	15 (.591)	20 (.787)	25 (.984)
B	5 (.197)	7 (.276)	10 (.394)
A	6 (.236)	12 (.472)	12 (.472)

DIMENSIONS ARE:  $\frac{\text{MM}}{\text{(INCHES)}}$

### SHAFT STYLE "F"

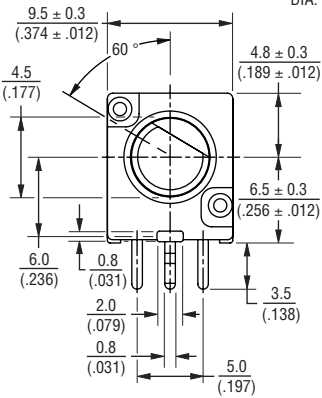
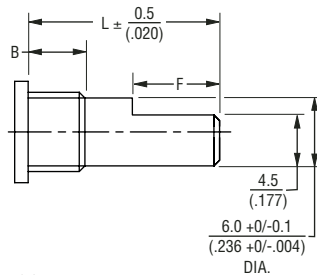

SHAFT SHOWN IN CCW POSITION

L	15 (.591)	20 (.787)	25 (.984)
B	5 (.197)	7 (.276)	10 (.394)
F	7 (.276)	12 (.472)	12 (.472)

## Derating Curve

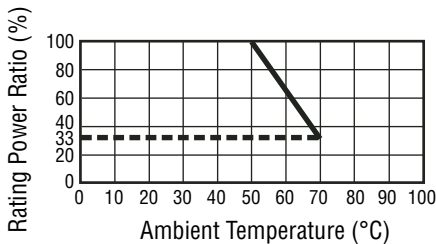

## How To Order

### PTR90 1 - 2 0 20 K - B 203

- Model
- PTR90 = With Rotary Switch
- No. of Sections
- 1 = 1 Section
  - 2 = 2 Sections
  - 3 = 3 Sections
  - 4 = 4 Sections
  - 5 = 5 Sections
  - 6 = 6 Sections
  - 8 = 8 Sections
- Pin Style
- 1 = PC Pins vertical/down facing and  $\pm 10\%$  Total Resistance Tolerance
  - 2 = PC Pins vertical/down facing and  $\pm 20\%$  Total Resistance Tolerance
- Center Detent Option
- 0 = No Detent
  - 2 = Center Detent
- Standard Shaft Length
- 15 = 15 mm
  - 20 = 20 mm
  - 25 = 25 mm
- Shaft Styles
- K = Knurled Type Shaft (Metal) 18 Toothed Serration Type
  - F = Flatted Metal Shaft
- Resistance Taper
- A = Audio Taper
  - B = Linear Taper
- Resistance Code (See Table)
- Other taper and shaft styles available.

## Standard Resistance Table

Resistance (Ohms)	Resistance Code
1,000	102
2,000	202
5,000	502
10,000	103
20,000	203
50,000	503
100,000	104
200,000	204
500,000	504
1,000,000	105