

PBL 3770A

High Performance Stepper Motor Drive Circuit

Description

PBL 3770A is a bipolar monolithic circuit intended to control and drive the current in one winding of a stepper motor. It is a high power version of PBL 3717 and special care has been taken to optimize the power handling capability without suffering in reliability.

The circuit consists of a LS-TTL compatible logic input stage, a current sensor, a monostable multivibrator and a high power H-bridge output stage. The circuit is pin-compatible with the PBL 3717 industry-standard driver.

Two PBL 3770A and a small number of external components form a complete control and drive unit for LS-TTL or microprocessor-controlled stepper motor systems.

Key Features

- Half-step and full-step operation.
- Switched mode bipolar constant current drive
- Wide range of current control 5 — 1800 mA.
- Wide voltage range 10 — 45 V.
- Designed for unstabilized motor supply voltage.
- Current levels can be selected in steps or varied continuously.
- Thermal overload protection.

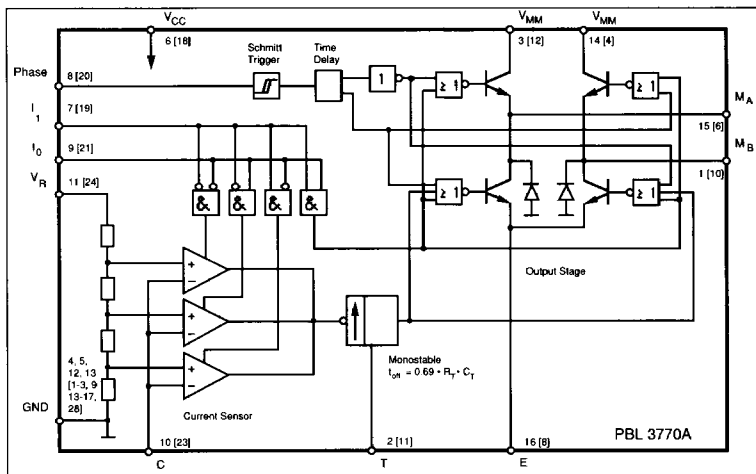
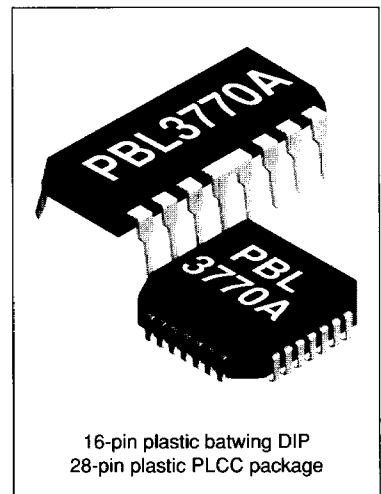

Figure 1. Block diagram.



Maximum Ratings

Parameter	Pin no. *	Symbol	Min	Max	Unit
Voltage					
Logic supply	6 [18]	V_{CC}	0	7	V
Motor supply	3, 14 [4, 12]	V_{MM}	0	45	V
Logic inputs	7, 8, 9 [19, 20, 21]	V_I	-0.3	6	V
Comparator input	10 [23]	V_C	-0.3	V_{CC}	V
Reference input	11 [24]	V_R	-0.3	15	V
Current					
Motor output current	1, 15 [6, 10]	I_M	-1.8	+1.8	A
Logic inputs	7, 8, 9 [19, 20, 21]	I_I	-10		mA
Analog inputs	10, 11 [23, 24]	I_A	-10		mA
Temperature					
Junction temperature		T_J		+150	°C
Operating ambient temperature		T_a	0	+70	°C
Storage temperature		T_s	-55	+150	°C

* [no] refers to PLCC package pin no.

Recommended Operating Conditions

Parameter	Symbol	Min	Typ	Max	Unit
Logic supply voltage	V_{CC}	4.75	5	5.25	V
Motor supply voltage	V_{MM}	10		40	V
Motor output current	I_M	-1.5		+1.5	A
Ambient temperature	T_a	0		+70	°C
Rise time logic inputs	t_r			2	µs
Fall time logic inputs	t_f			2	µs

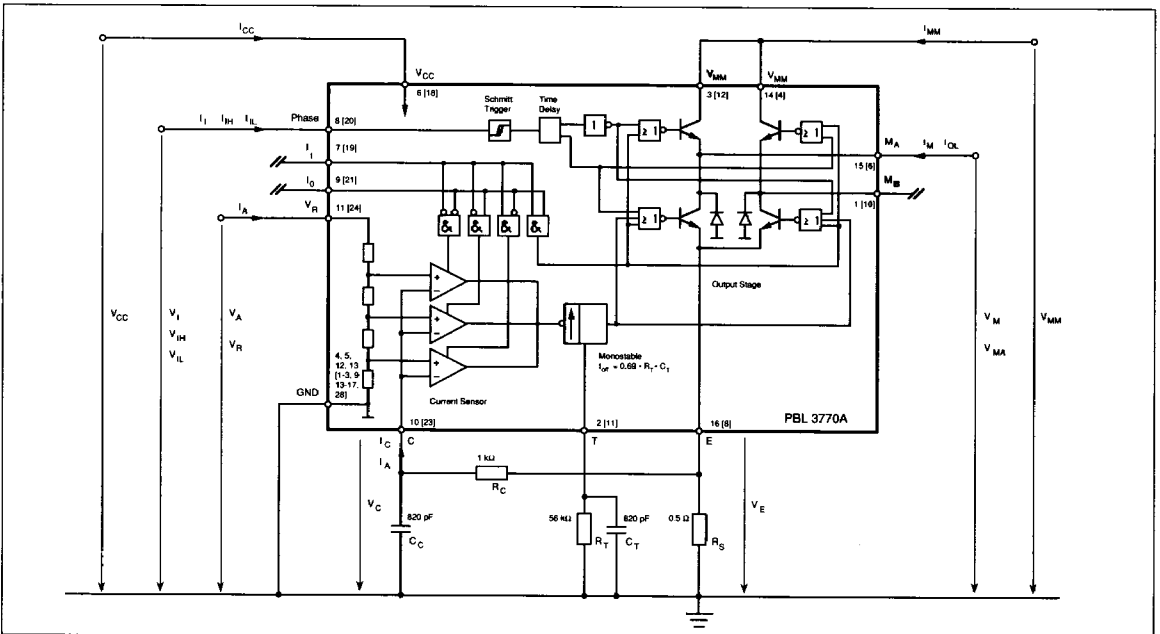

Figure 2. Definition of symbols.

Electrical Characteristics

Electrical characteristics over recommended operating conditions. $C_T = 820$ pF, $R_T = 56$ kohm.

Parameter	Symbol	Ref. fig.	Conditions	Min	Typ	Max	Unit
General							
Supply current	I_{CC}	2	$V_{MM} = 20$ to 40 V, $I_0 = I_1 =$ HIGH.		30	40	mA
			$V_{MM} = 20$ to 40 V, $I_0 = I_1 =$ LOW, $f_s = 23$ kHz		48	65	mA
Total power dissipation	P_D		$f_s = 28$ kHz, $I_M = 1.0$ A, $V_{MM} = 36$ V Note 2, 4.		1.9	2.3	W
			$f_s = 24$ kHz, $I_M = 1.0$ A, $V_{MM} = 12$ V Note 2, 4.		1.7	2.1	W
			$f_s = 28$ kHz, $I_M = 1.3$ A, $V_{MM} = 36$ V Note 3, 4.		2.7	3.2	W
			$f_s = 28$ kHz, $I_M = 1.5$ A, $V_{MM} = 36$ V Note 3, 4.		3.5		W
Turn-off delay	t_d	3	$T_a = +25^\circ\text{C}$, $dV_C/dt \geq 50$ mV/ μs .			2.5	μs
Thermal shutdown junction temperature					170		$^\circ\text{C}$
Logic Inputs							
Logic HIGH input voltage	V_{IH}	2		2.0			V
Logic LOW input voltage	V_{IL}	2				0.8	V
Logic HIGH input current	I_{IH}	2	$V_I = 2.4$ V			20	μA
Logic LOW input current	I_{IL}	2	$V_I = 0.4$ V	-0.4			mA
Analog Inputs							
Comparator threshold voltage	V_{CH}	2	$V_R = 5.0$ V, $I_0 = I_1 =$ LOW	400	415	430	mV
Comparator threshold voltage	V_{CM}	2	$V_R = 5.0$ V, $I_0 =$ HIGH, $I_1 =$ LOW	240	250	265	mV
Comparator threshold voltage	V_{CL}	2	$V_R = 5.0$ V, $I_0 =$ LOW, $I_1 =$ HIGH	70	80	90	mV
Input current	I_C	2		-20			μA
Motor Outputs							
Lower transistor saturation voltage			$I_M = 1.0$ A		0.5	0.8	V
			$I_M = 1.3$ A		0.8	1.3	V
Lower diode forward voltage drop			$I_M = 1.0$ A		1.3	1.6	V
			$I_M = 1.3$ A		1.5	1.8	V
Upper transistor saturation voltage			$I_M = 1.0$ A		1.1	1.3	V
			$I_M = 1.3$ A		1.3	1.6	V
Output leakage current			$I_0 = I_1 =$ HIGH, $T_a = +25^\circ\text{C}$			100	μA
Monostable							
Cut off time	t_{off}	3	$V_{MM} = 10$ V, $t_{on} \geq 5$ μs	27	31	35	μs

Thermal Characteristics

Parameter	Symbol	Ref. Fig.	Conditions	Min	Typ	Max	Unit
Thermal resistance	$R_{th_{j-c}}$		DIP package.		11		$^\circ\text{C}/\text{W}$
	$R_{th_{j-a}}$	15	DIP package. Note 2.		40		$^\circ\text{C}/\text{W}$
	$R_{th_{j-c}}$		PLCC package.		9		$^\circ\text{C}/\text{W}$
	$R_{th_{j-a}}$	15	PLCC package. Note 2.		35		$^\circ\text{C}/\text{W}$

Notes

- All voltages are with respect to ground. Currents are positive into, negative out of specified terminal.
- All ground pins soldered onto a 20 cm² PCB copper area with free air convection. $T_a = +25^\circ\text{C}$.
- DIP package with external heatsink (Staver V7) and minimal copper area. Typical $R_{th_{j-a}} = 27.5^\circ\text{C}/\text{W}$. $T_a = +25^\circ\text{C}$.
- Not covered by final test program.

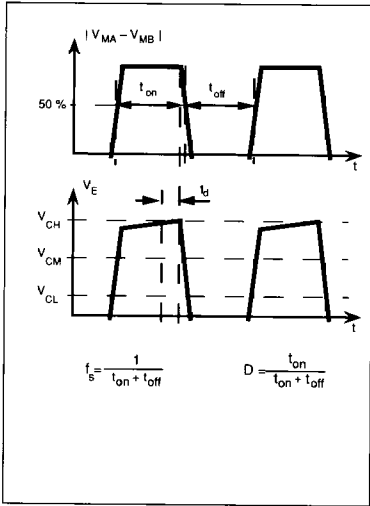

Figure 3. Definition of terms.

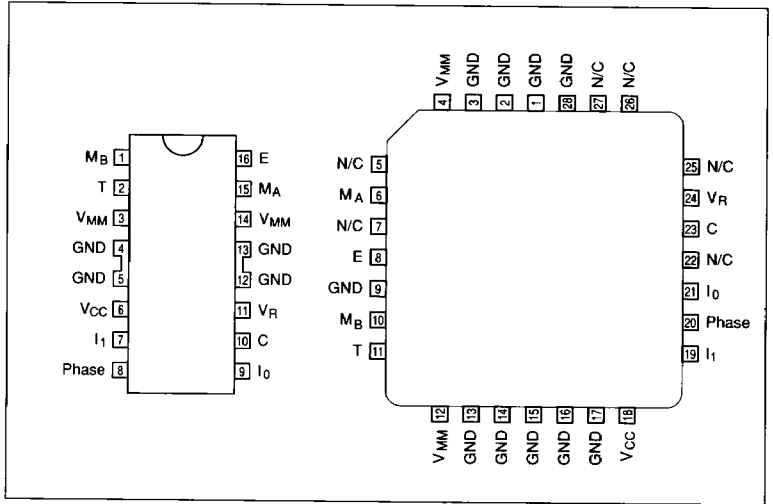

Figure 4. Pin configurations.

Functional Description

The PBL 3770A is intended to drive a bipolar constant current through one winding of a 2-phase stepper motor.

Current control is achieved through switched-mode regulation, see figure 5 and 6.

Three different current levels and zero current can be selected by the input logic.

The circuit contains the following functional blocks:

- Input logic
- Current sense
- Single-pulse generator
- Output stage

Input logic

Phase input. The phase input determines the direction of the current in the motor winding. High input forces the current from terminal M_A to M_B and low input from terminal M_B to M_A . A Schmitt trigger provides noise immunity and a delay circuit eliminates the risk of cross conduction in the output stage during a phase shift.

Half- and full-step operation is possible.

Current level selection. The status of I_0 and I_1 inputs determines the current level in the motor winding. Three fixed current levels can be selected according to the table below.

Motor current		I_0	I_1
High level	100%	L	L
Medium level	60%	H	L
Low level	20%	L	H
Zero current	0%	H	H

The specific values of the different current levels are determined by the reference voltage V_R together with the value of the sensing resistor R_S .

The peak motor current can be calculated as follows:

$$i_m = (V_R \cdot 0.080) / R_S \text{ [A]}, \text{ at 100\% level}$$

The motor current can also be continuously varied by modulating the voltage reference input.

Current sensor

The current sensor contains a reference voltage divider and three comparators for measuring each of the selectable current levels. The motor current is sensed as a voltage drop across the current sensing resistor, R_S , and compared with one of the voltage references from the divider. When the two voltages are equal, the comparator triggers the single-pulse generator. Only one comparator at a time is activated by the input logic.

Single-pulse generator

The pulse generator is a monostable multivibrator triggered on the positive

edge of the comparator output. The multivibrator output is high during the pulse time, t_{on} , which is determined by the timing components R_T and C_T .

$$t_{off} = 0.69 \cdot R_T \cdot C_T$$

The single pulse switches off the power feed to the motor winding, causing the winding to decrease during t_{off} .

If a new trigger signal should occur during t_{off} , it is ignored.

Output stage

The output stage contains four transistors and two diodes, connected in an H-bridge. Note that the upper recirculation diodes are connected to the circuit externally. The two sinking transistors are used to switch the power supplied to the motor winding, thus driving a constant current through the winding. See figures 5 and 6.

Overload protection

The circuit is equipped with a thermal shut-down function, which will limit the junction temperature. The output current will be reduced if the maximum permissible junction temperature is exceeded. It should be noted, however, that it is not short circuit protected.

Operation

When a voltage V_{MM} is applied across the motor winding, the current rise follows the equation:

$$i_m = (V_{MM} / R) \cdot (1 - e^{-(R \cdot t) / L})$$

R = Winding resistance
 L = Winding inductance
 t = time
 (see figure 6, arrow 1)

The motor current appears across the external sensing resistor, R_s , as an analog voltage. This voltage is fed through a low-pass filter, $R_c C_c$, to the voltage comparator input (pin 10). At the moment the sensed voltage rises above the comparator threshold voltage, the monostable is triggered and its output turns off the conducting sink transistor.

The polarity across the motor winding reverses and the current is forced to circulate through the appropriate upper protection diode back through the source transistor (see figure 6, arrow 2).

After the monostable has timed out, the current has decayed and the analog voltage across the sensing resistor is below the comparator threshold level.

The sinking transistor then turns on and the motor current starts to increase again. The cycle is repeated until the current is turned off via the logic inputs.

When both I_s and I_o are high, all four transistors in the output H-bridge are turned off, which means that inductive current recirculates through two opposite free-wheeling diodes (see figure 6, arrow 3). this method of turning off the current results in a faster current decay than if only one transistor was turned off and will therefore improve speed performance in half-stepping mode.

Heatsinking

The junction temperature of the chip highly effects the lifetime of the circuit. In high-current applications, the heatsinking must be carefully considered.

The $R_{th_{ja}}$ of the PBL 3770A can be reduced by soldering the ground pins to a suitable copper ground plane on the printed circuit board (see figure 14) or by applying an external heatsink type V7 or V8, see figure 14.

The diagram in figure 13 shows the maximum permissible power dissipation versus the ambient temperature in °C, for heatsinks of the type V7, V8, or a 20 cm² copper area respectively. Any external heatsink or printed circuit board copper must be connected to electrical ground.

For motor currents higher than approx 600 mA, some form of heatsinking is recommended to assure optimal

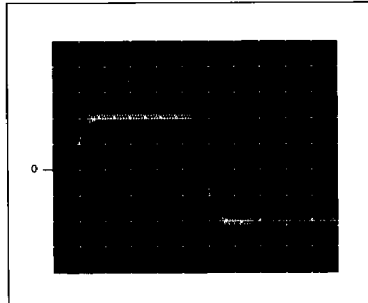

Figure 5. Motor current (I_M),
 Vertical : 200 mA/div,
 Horizontal: 1 ms/div,
 expanded part 100 μ s/div.

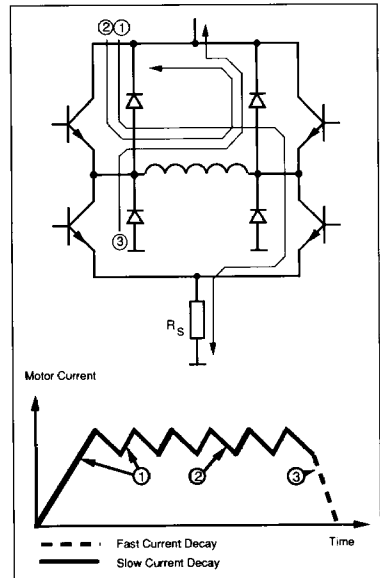

Figure 6. Output stage with current paths for fast and slow current decay.

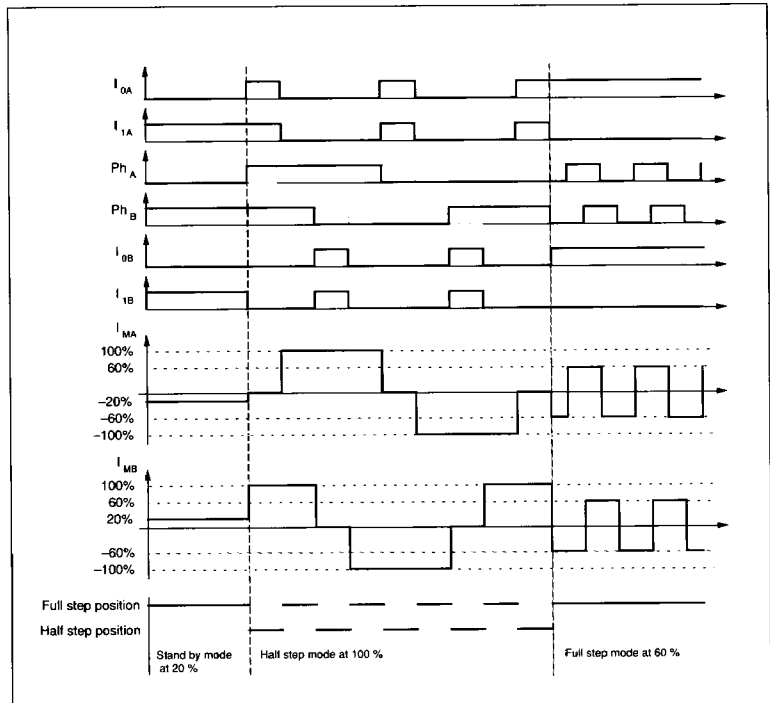
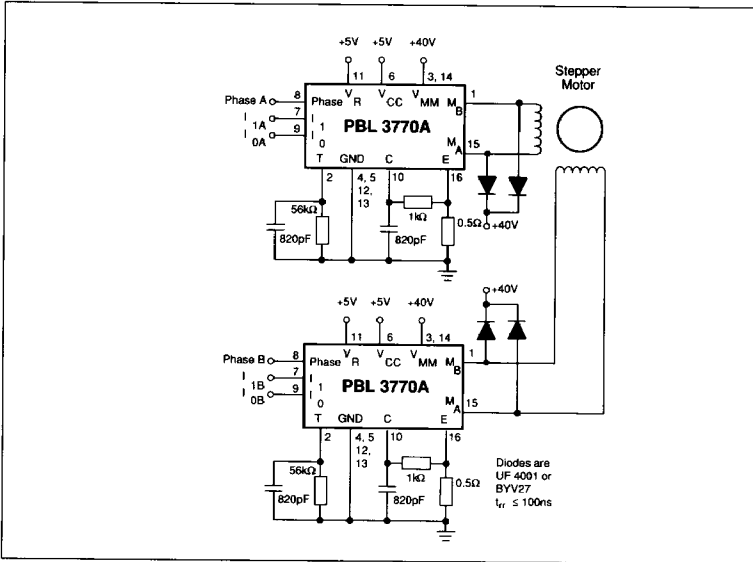

Figure 7. Principal operating sequence.



reliability.

The diagrams in figures 12 and 13 can be used to determine the required heatsinking of the circuit. In some systems, forced-air cooling may be available to reduce the temperature rise of the circuit.

Applications Information

Motor selection

Some stepper motors are not designed for continuous operation at maximum current. As the circuit drives a constant current through the motor, its temperature can increase, both at low- and high-speed operation.

Some stepper motors have such high core losses that they are not suited for switched-mode operation.

Interference

As the circuit operates with switched-mode current regulation, interference-generation problems can arise in some applications. A good measure is then to decouple the circuit with a 0.1 μ F ceramic capacitor, located near the package across the power line V_{MM} and ground.

Also make sure that the V_{Ref} input is sufficiently decoupled. An electrolytic capacitor should be used in the +5 V rail, close to the circuit.

The ground leads between R_s , C_c and circuit GND should be kept as short as possible. This applies also to the leads connecting R_s and R_c to pin 16 and pin 10 respectively.

In order to minimize electromagnetic interference, it is recommended to route M_a and M_b leads in parallel on the printed circuit board directly to the terminal connector. The motor wires should be twisted in pairs, each phase separately, when installing the motor system.

Unused inputs

Unused inputs should be connected to proper voltage levels in order to obtain the highest possible noise immunity.

Ramping

A stepper motor is a synchronous motor and does not change its speed due to load variations. This means that the torque of the motor must be large enough to match the combined inertia of the motor and load for all operation modes. At speed changes, the required torque increases by the square, and the required

Figure 8. Typical stepper motor driver application with PBL 3770A.

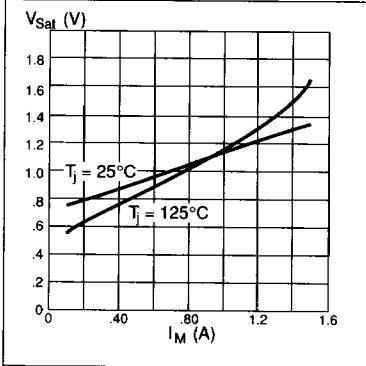

Figure 9. Typical source saturation vs. output current.

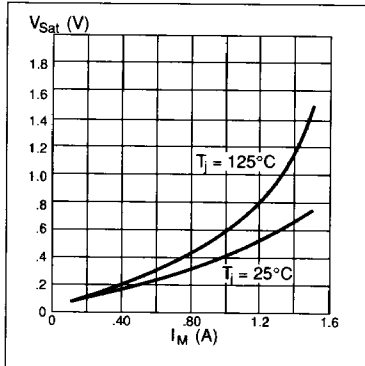

Figure 10. Typical sink saturation vs. output current.

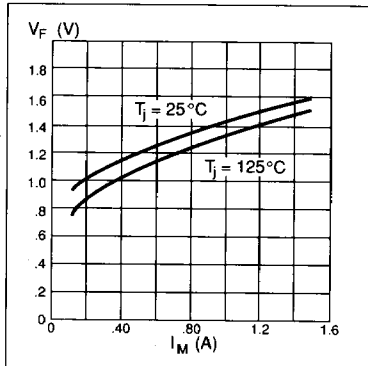

Figure 11. Typical lower diode voltage drop vs. recirculating current.

power by the cube of the speed change. Ramping, i.e., controlled acceleration or deceleration must then be considered to avoid motor pull-out.

V_{CC} , V_{MM}

The supply voltages, V_{CC} and V_{MM} , can be turned on or off in any order. Normal dv/dt values are assumed.

Before a driver circuit board is removed from its system, all supply voltages must be turned off to avoid destructive transients being generated by the motor.

Switching frequency

The motor inductance, together with the pulse time, t_{off} , determines the switching frequency of the current regulator. The choice of motor may then require other values on the R_T , C_T components than those recommended in figure 6, to obtain a switching frequency above the audible range. Switching frequencies above 40 kHz are not recommended because the current regulation can be affected.

Analog control

As the current levels can be continuously controlled by modulating the V_R input, limited microstepping can be achieved.

Sensor resistor

The R_S resistor should be of a non-inductive type power resistor. A 0.5 ohm resistor, tolerance $\leq 1\%$, is a good choice for 800 mA max motor current at $V_R = 5V$.

The peak motor current, i_m , can be calculated by using the formula:
 $i_m = (V_R \cdot 0.080) / R_S [A]$, at 100% level

External recirculation diodes

Recirculation diodes must be connected across each motor terminal and the supply voltage, V_{MM} . The anodes shall be connected to the motor terminals and the cathodes to the V_{MM} voltage. Ultra-fast recovery diodes should be used for maximum performance and reliability.

Ordering Information

Package	Temp. range	Part No.
Plastic DIP	0 to 70°C	PBL3770AN
PLCC	0 to 70°C	PBL3770AQN

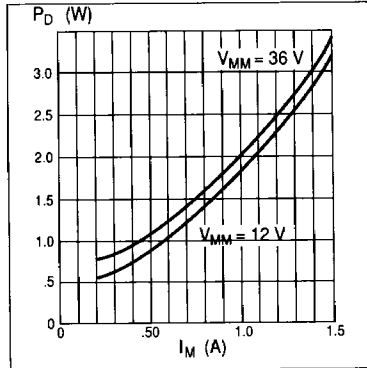

Figure 12. Typical power dissipation vs. motor current.

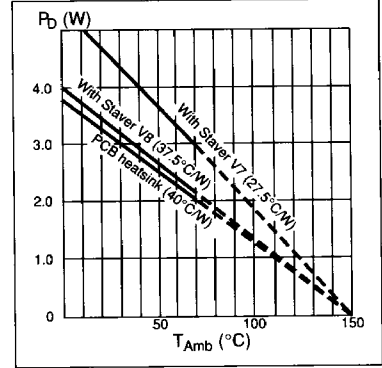

Figure 13. Allowable power dissipation vs. ambient temperature.

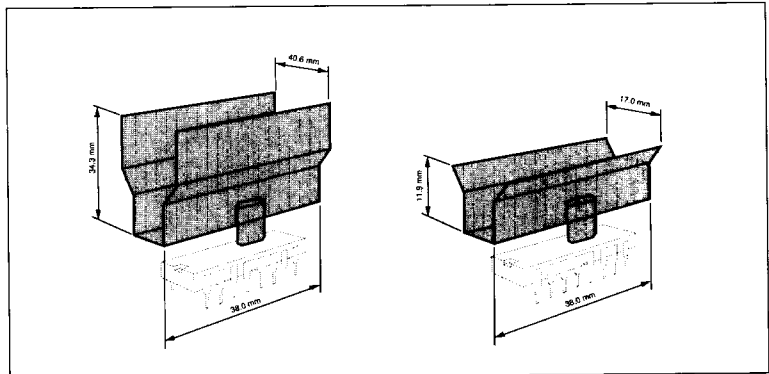

Figure 14. Heatsinks, Staver, type V7 and V8 by Columbia-Staver UK.

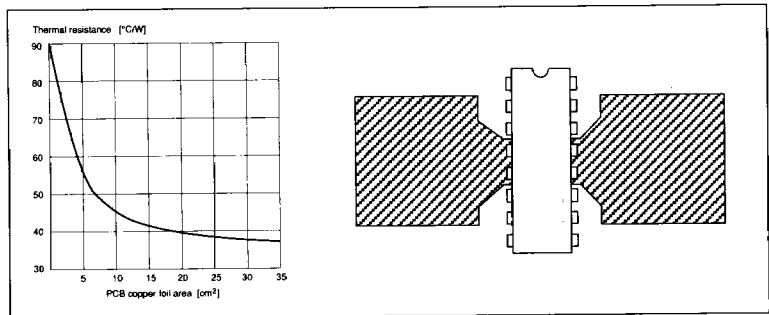

Figure 15. Copper foil used as a heatsink.

Description	DIP	PLCC
$R_{th_{jc}}$, Junction to Case (Case = ground pin)	11°C/W	9°C/W
$R_{th_{ja}}$, Junction to Ambient*	40°C/W	35°C/W

* For the DIP, the four ground pins soldered to a 20 cm² ground plane according to figure 15. For the PLCC, all ground pins are soldered to a 20 cm² ground plane located as close as possible to the device and on both sides of a double sided PCB.

Table 1. Thermal resistance. Thermal resistance values are heavily dependant on location and shape of heatsinks.

T-90-20

5-lead TO-220

dim.	millimeters		inches	
	min.	max.	min.	max.
A	3.53	3.91	0.139	0.154
B	9.66	10.66	0.380	0.420
C	3.55	4.80	0.140	0.189
D	1.05	1.39	0.041	0.055
E	2.04	2.92	0.080	0.155
F	0.38	0.50	0.015	0.020
G	2.54	3.05	0.100	0.120
H		3.00		0.118
I	1.50	1.90	0.059	0.075
J	12.50	14.50	0.492	0.571
K	14.32	15.52	0.564	0.611
L	0.81	0.95	0.032	0.037
M	5.85	6.85	0.230	0.270

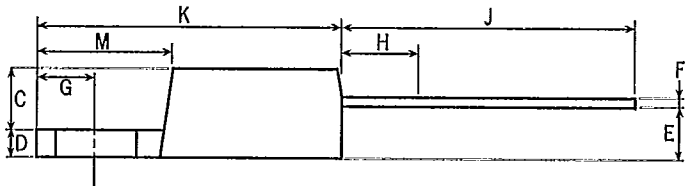
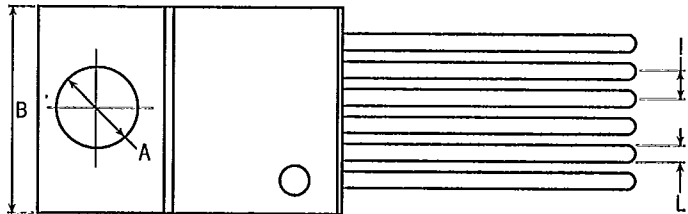
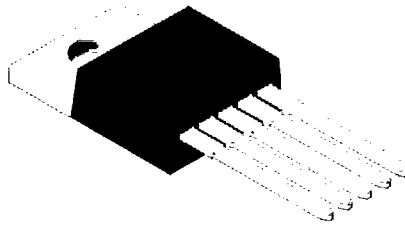

16-lead small outline package

dim.	millimeters		inches	
	min.	max.	min.	max.
A	2.35	2.65	0.093	0.104
B	0.33	0.51	0.013	0.020
C	0.23	0.32	0.009	0.012
D	1.27	typical	0.050	typical
E	7.40	7.60	0.291	0.299
F	10.00	10.65	0.394	0.419
G	0.40	1.27	0.016	0.050
H	10.10	10.50	0.397	0.460
I	0.66		0.026	

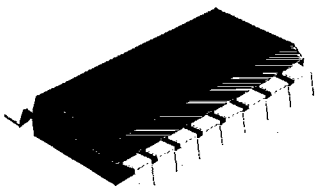
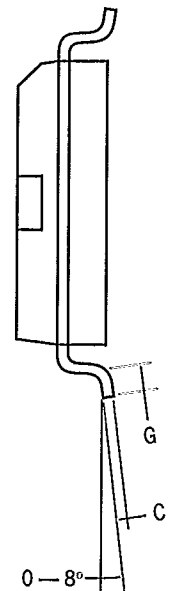
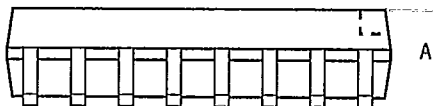
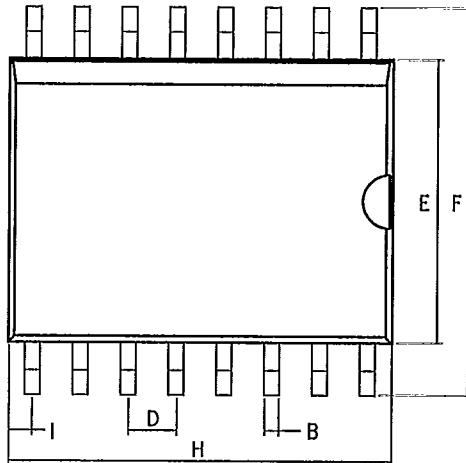

T-90-20

16-pin dual in-line package

dim.	millimeters		inches	
	min.	max.	min.	max.
A	0.39		0.015	
B	0.13		0.005	
C	0.36	0.56	0.014	0.022
D	2.54 typical		0.100 typical	
E		5.33		0.210
F	2.93	4.06	0.115	0.160
G	7.62	8.25	0.300	0.325
H	0.20	0.38	0.008	0.015
I	18.93	21.33	0.745	0.840
J	6.10	7.11	0.240	0.280
K	2.93	4.95	0.115	0.195
L		10.92		0.430
M	1.15	1.77	0.045	0.070

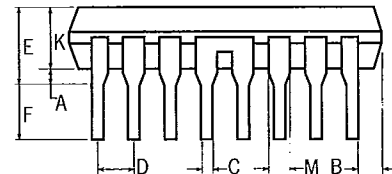
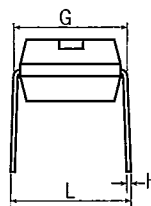
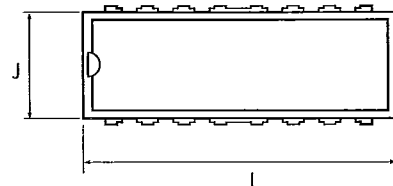
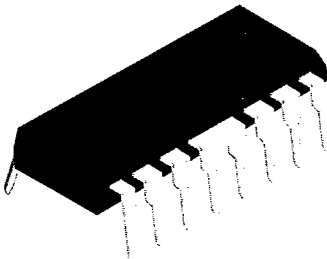
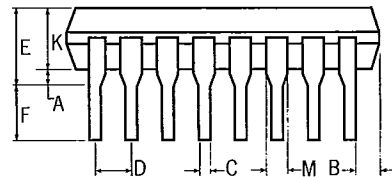
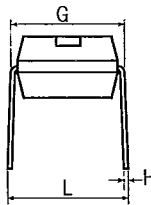
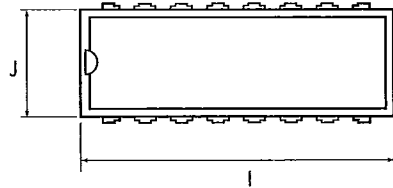
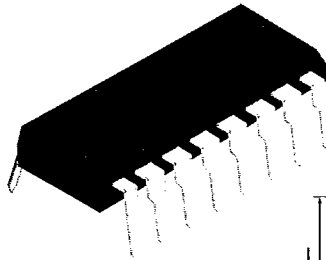

22-pin dual in-line package

T-90-20

dim.	millimeters		inches	
	min.	max.	min.	max.
A	0.39		0.015	
B	0.13		0.005	
C	0.36	0.56	0.014	0.022
D	2.54	typical	0.100	typical
E		5.33		0.210
F	2.93	4.06	0.115	0.160
G	9.91	10.79	0.390	0.425
H	0.20	0.38	0.008	0.015
I	26.67	28.44	1.050	1.120
J	8.39	9.65	0.330	0.380
K	3.18	4.95	0.125	0.195
L		12.70		0.500
M	0.77	1.77	0.030	0.070
N	0.56	1.17	0.022	0.046

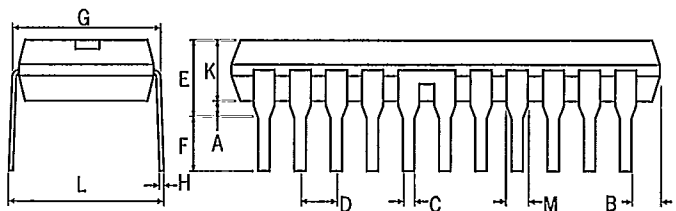
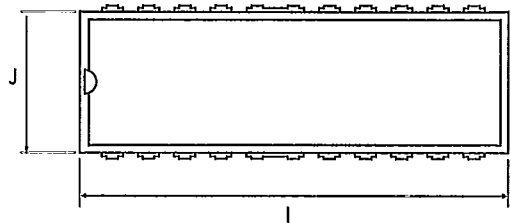
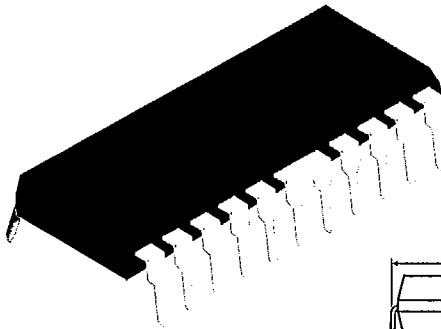
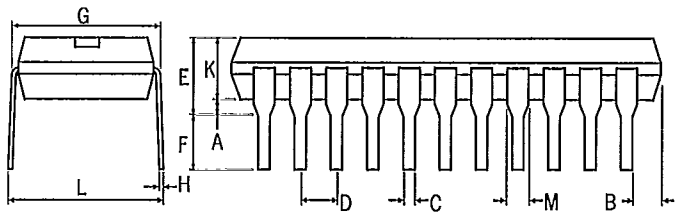
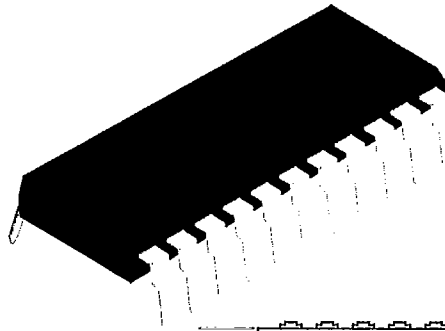

T-90-20

24-pin dual in-line package

dim.	millimeters		inches	
	min.	max.	min.	max.
A	0.39		0.015	
B	0.13		0.005	
C	0.36	0.56	0.014	0.022
D	2.54	typical	0.100	typical
E		5.33		0.210
F	2.93	4.06	0.115	0.160
G	7.62	8.25	0.300	0.325
H	0.20	0.38	0.008	0.015
I	28.60	32.30	1.125	1.275
J	6.10	7.11	0.240	0.280
K	2.93	4.95	0.115	0.195
L		10.92		0.430
M	1.15	1.77	0.045	0.070

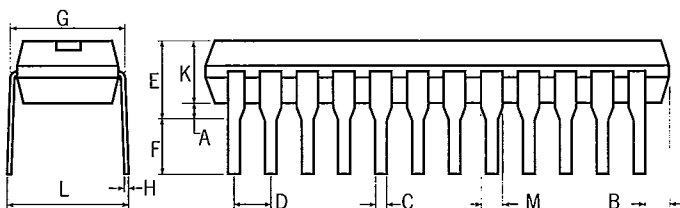
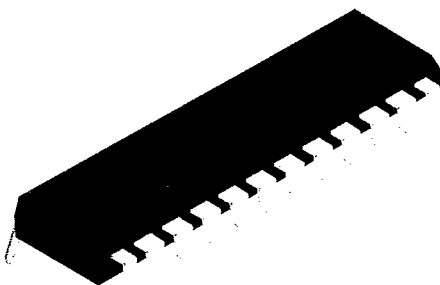

28-lead PLCC package

dim.	millimeters		inches	
	min.	max.	min.	max.
A	12.32	12.57	0.485	0.495
B	11.43	11.58	0.450	0.456
C	0.66	0.81	0.026	0.032
D	2.29	3.04	0.090	0.120
E	9.91	10.92	0.390	0.430
F	4.20	4.57	0.165	0.180
G	1.27 typical		0.050 typical	
I	0.51		0.020	
J	0.33	0.53	0.013	0.027

