

NJM2340

■BLOCK DIAGRAM

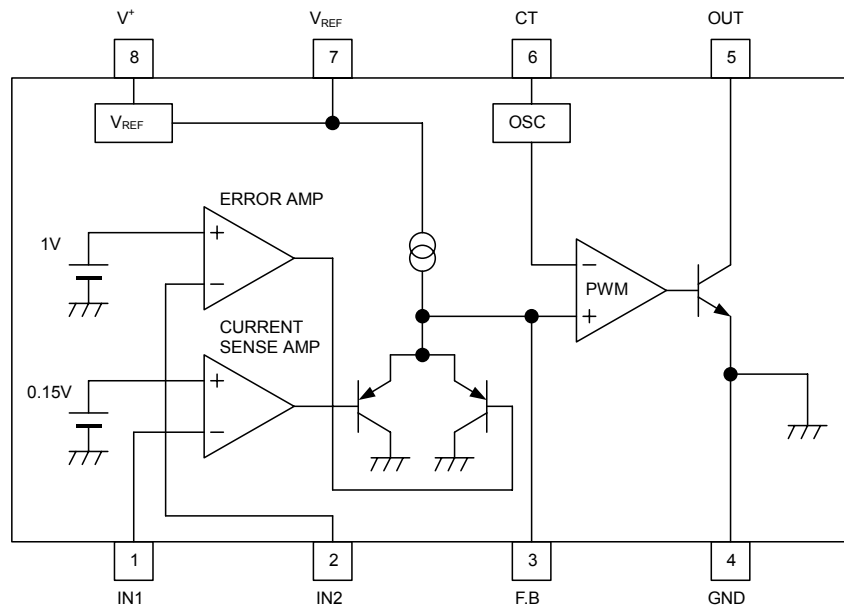

■ABSOLUTE MAXIMUM RATINGS (Ta=25°C)

PARAMETER	SYMBOL	RATINGS	UNIT
Maximum Supply Voltage	V^+	36	V
Output Sink Current	I_{SINK}	15	mA
Power Dissipation	P_D	(DMP8) 300 (TVSP8) 320	mW
Operating Temperature Range	T_{opr}	-40 ~ +85	°C
Storage Temperature Range	T_{stg}	-50 ~ +150	°C

■RECOMMENDED OPERATING CONDITIONS (Ta=25°C)

PARAMETER	SYMBOL	MIN.	MAX.	UNIT
Supply Voltage	V^+	3.6	32	V
Oscillation Frequency	f_{osc}	20	500	kHz
Oscillator Timing Resistance	R_T	20	100	kΩ

■ ELECTRICAL CHARACTERISTICS ($V^+=12V, T_a=25^\circ C$)

REFERENCE VOLTAGE BLOCK

PARAMETER	SYMBOL	TEST CONDITION	MIN.	TYP.	MAX.	UNIT
Output Voltage	V_{REF}	$I_{OR}=1mA$	1.98	2.00	2.02	V
Line Regulation	L_{INE}	$V^+=3.6 \sim 32V, I_{OR}=1mA$	–	4.0	20	mV
Load Regulation	L_{OAD}	$I_{OR}=0.1 \sim 5.0mA$	–	6.0	40	mV

OSCILLATOR BLOCK

PARAMETER	SYMBOL	TEST CONDITION	MIN.	TYP.	MAX.	UNIT
Oscillation Frequency	f_{OSC}	$R_T=27k\Omega, C_T=220pF$	315	350	385	kHz

CURRENT SENSE AMPLIFIER BLOCK

PARAMETER	SYMBOL	TEST CONDITION	MIN.	TYP.	MAX.	UNIT
Reference Voltage1	V_{B1}		144	150	156	mV
Input Bias Voltage1	I_{B1}		–	20	100	nA
Maximum Output Voltage1 (F.B Pin)	V_{OM+1}	$R_{NF}=100k\Omega$	–	V_{REF} -0.15	–	V
	V_{OM-1}	$R_{NF}=100k\Omega$	0.6	0.75	0.9	V
Maximum Source Current1 (F.B Pin)	I_{OM1}	$V_{OM1}=0.5V$	40	85	200	μA

ERROR AMPLIFIER BLOCK

PARAMETER	SYMBOL	TEST CONDITION	MIN.	TYP.	MAX.	UNIT
Reference Voltage2	V_{B2}		0.985	1.000	1.015	V
Input Bias Voltage2	I_{B2}		–	20	100	nA
Maximum Output Voltage2 (F.B Pin)	V_{OM+2}	$R_{NF}=100k\Omega$	–	V_{REF} -0.15	–	V
	V_{OM-2}	$R_{NF}=100k\Omega$	0.6	0.75	0.9	V
Maximum Source Current2 (F.B Pin)	I_{OM2}	$V_{OM2}=0.5V$	40	85	200	μA

PWM COMPARE BLOCK

PARAMETER	SYMBOL	TEST CONDITION	MIN.	TYP.	MAX.	UNIT
Input Threshold Voltage (F.B Pin)	V_{TH0}	duty-cycle=0% (note)	V_{OM-}	1.0	1.1	V
Input Threshold Voltage (F.B Pin)	V_{TH100}	duty-cycle=100% (note)	–	1.4	–	V

OUTPUT BLOCK

PARAMETER	SYMBOL	TEST CONDITION	MIN.	TYP.	MAX.	UNIT
L Output Voltage (OUT Pin)	V_{OL}	$I_{SINK}=10mA$	–	0.5	0.7	V

GENERAL CHARACTERISTICS

PARAMETER	SYMBOL	TEST CONDITION	MIN.	TYP.	MAX.	UNIT
Average Quiescent Current	I_{CCAV}	$R_L=\infty, \text{duty-cycle}=50\%$	–	1.5	2.0	mA

(note) Duty-Cycle is defined as follows:

Duty-Cycle=0%: IC output transistor is OFF.

Duty-Cycle=100%: IC output transistor is ON.

NJM2340

■ TYPICAL APPLICATION

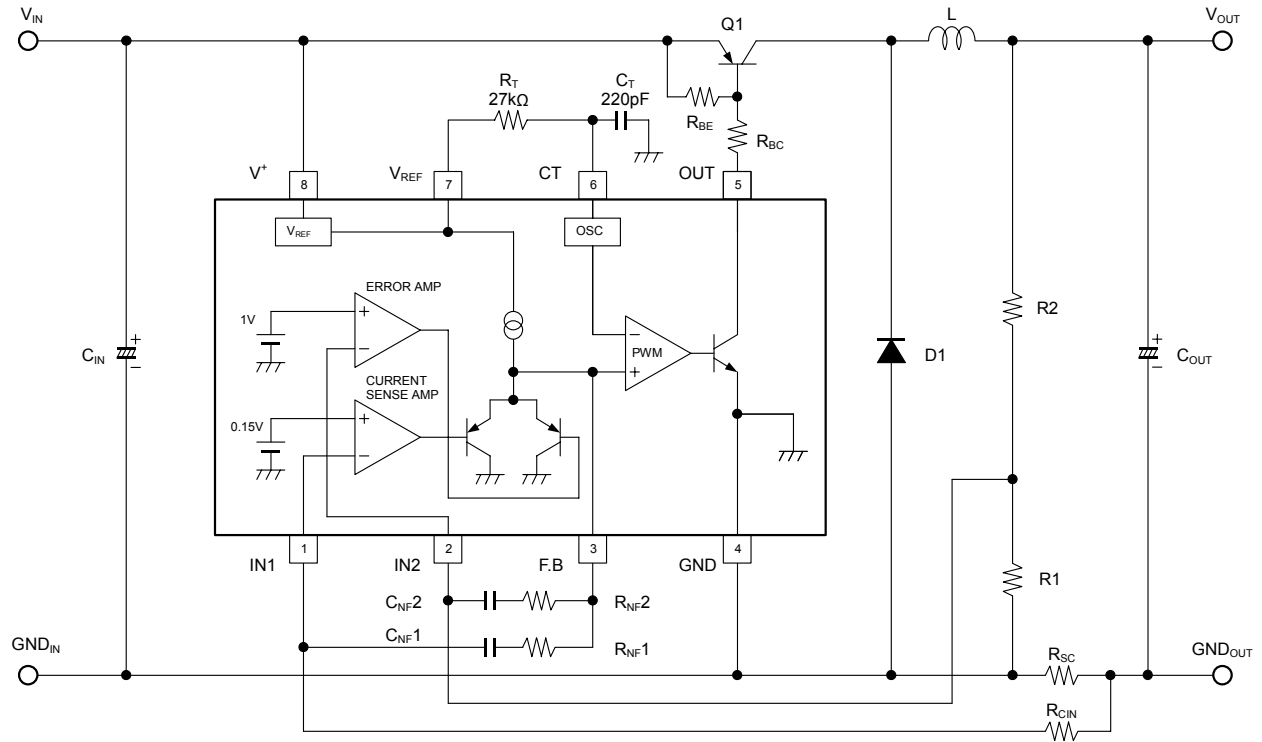

■ TYPICAL CHARACTERISTICS

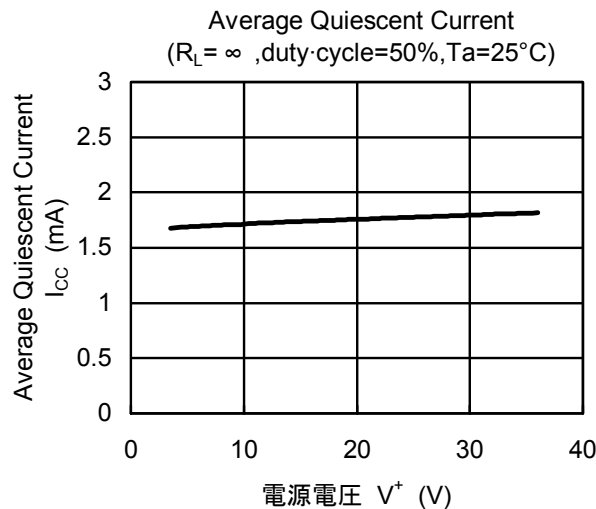
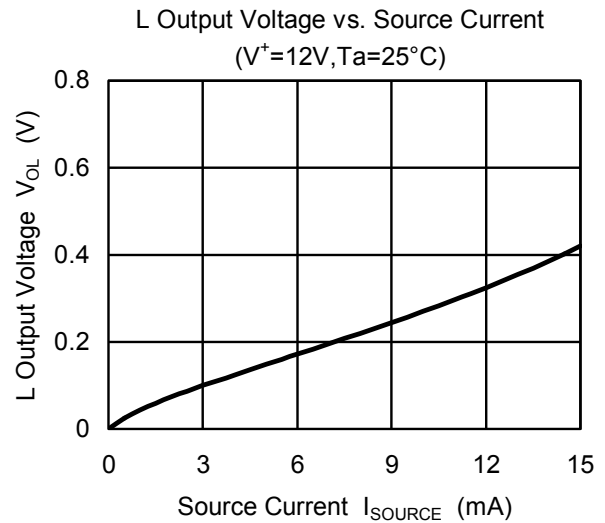
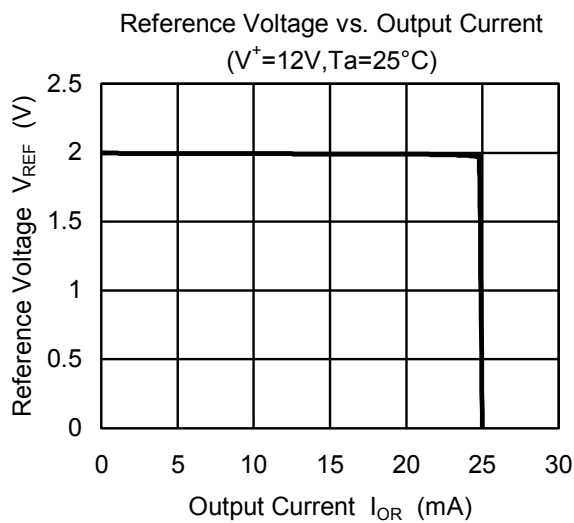
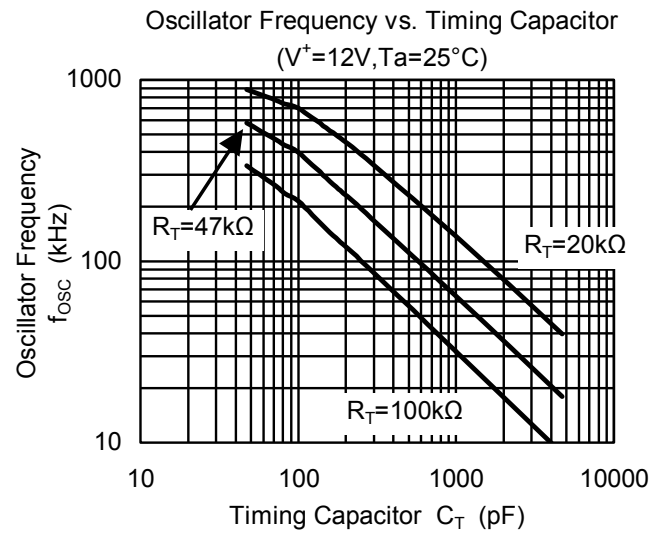
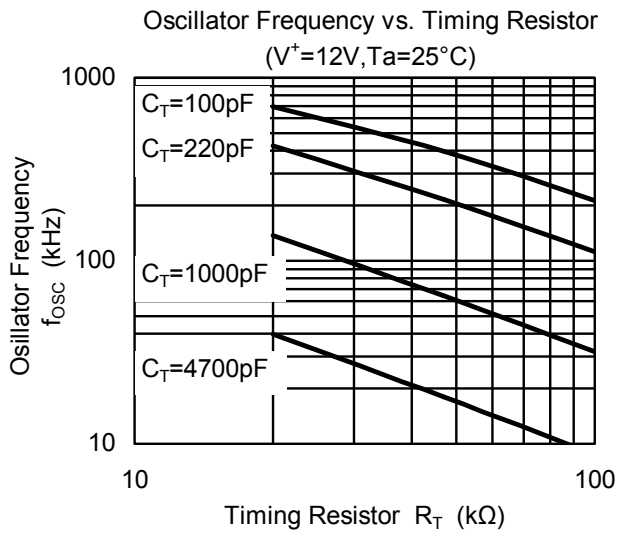

TYPICAL CHARACTERISTICS

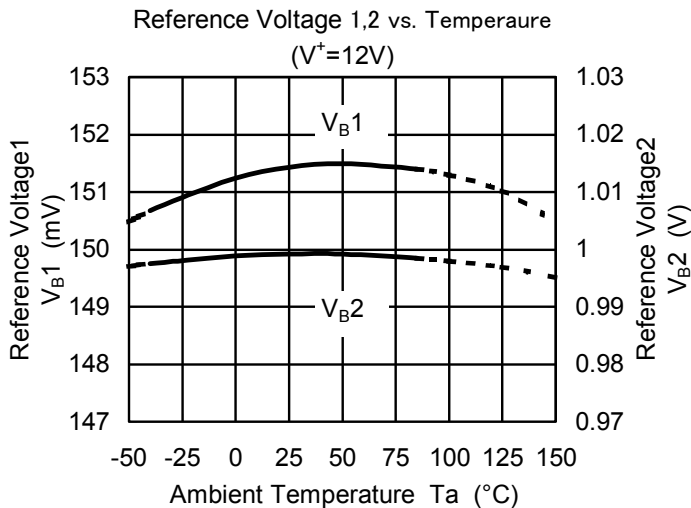
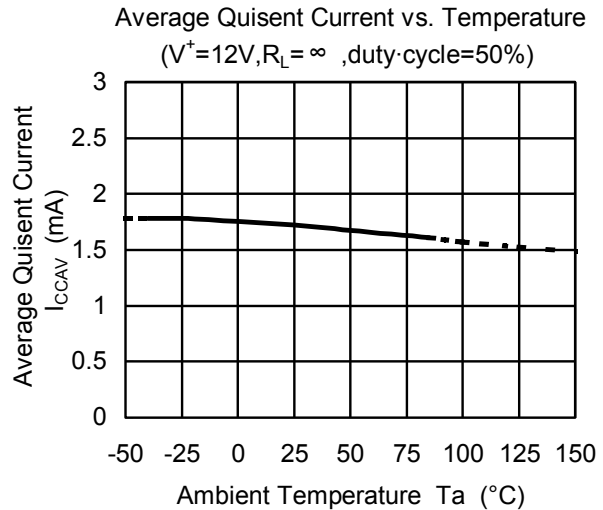
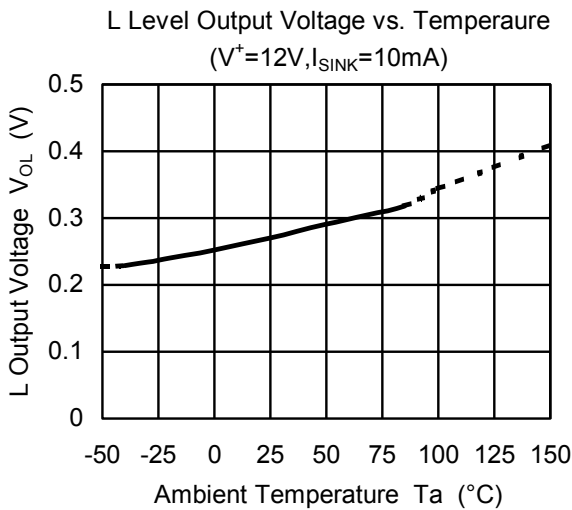
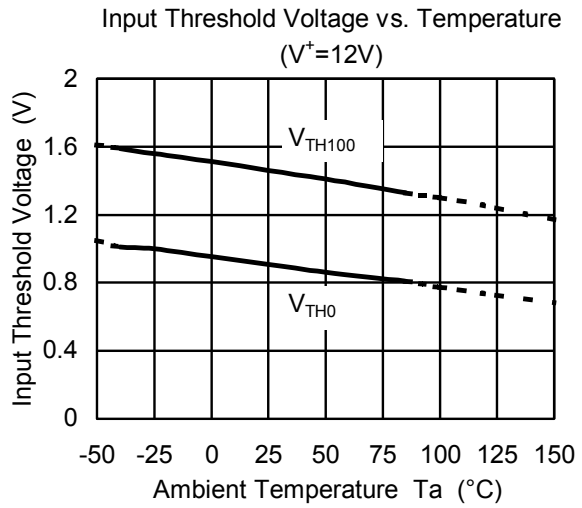
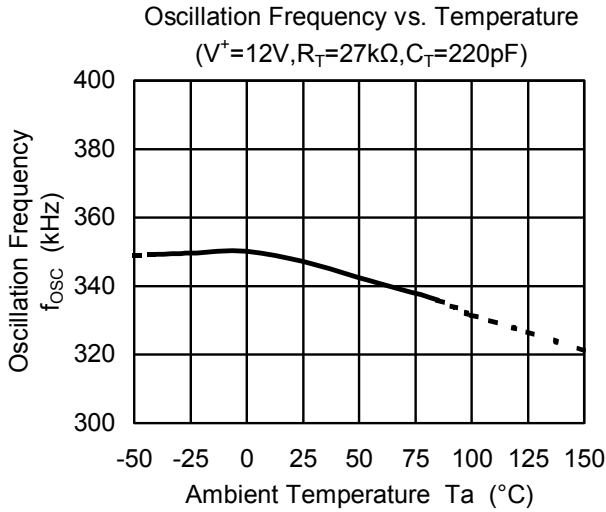

[CAUTION]
The specifications on this databook are only given for information, without any guarantee as regards either mistakes or omissions. The application circuits in this databook are described only to show representative usages of the product and not intended for the guarantee or permission of any right including the industrial rights.