

$V_{DSM}$	=	6500 V
$I_{TAVM}$	=	760 A
$I_{TRMS}$	=	1200 A
$I_{TSM}$	=	11600 A
$V_{T0}$	=	1.22 V
$r_T$	=	0.970 m $\Omega$

## Phase Control Thyristor

# 5STP 08G6500

Doc. No. 5SYA1006-03 Sep. 01

- Patented free-floating silicon technology
- Low on-state and switching losses
- Designed for traction, energy and industrial applications
- Optimum power handling capability

### Blocking

Part Number	5STP	5STP 08G6200	5STP 08G5800	Conditions
$V_{DSM}$ $V_{RSM}$	6500 V	6200 V	5800 V	$f = 5 \text{ Hz}$ , $t_p = 10 \text{ ms}$
$V_{DRM}$ $V_{RRM}$	5600 V	5300 V	4900 V	$f = 50 \text{ Hz}$ , $t_p = 10 \text{ ms}$
$V_{RSM1}$	7000 V	6700 V	6300 V	$t_p = 5 \text{ ms}$ , single pulse
$I_{DSM}$	$\leq 200 \text{ mA}$			$V_{DSM}$ $V_{RSM}$ $T_j = 125^\circ\text{C}$
$I_{RSM}$	$\leq 200 \text{ mA}$			
$dV/dt_{crit}$	2000 V/ $\mu\text{s}$			Exp. to $0.67 \times V_{DRM}$ , $T_j = 125^\circ\text{C}$

$V_{DRM}/V_{RRM}$  are equal to  $V_{DSM}/V_{RSM}$  values up to  $T_j = 110^\circ\text{C}$

### Mechanical data

$F_M$	Mounting force	nom.	22 kN
		min.	14 kN
		max.	24 kN
a	Acceleration		
	Device unclamped		50 m/s <sup>2</sup>
	Device clamped		100 m/s <sup>2</sup>
m	Weight		0.6 kg
$D_S$	Surface creepage distance		38 mm
$D_a$	Air strike distance		21 mm



ABB Semiconductors AG reserves the right to change specifications without notice.

# ABB

**On-state**

$I_{TAVM}$	Max. average on-state current	760 A	Half sine wave, $T_C = 70^\circ\text{C}$	
$I_{TRMS}$	Max. RMS on-state current	1200 A		
$I_{TSM}$	Max. peak non-repetitive	11600 A	$t_p = 10\text{ ms}$	$T_j = 125^\circ\text{C}$ After surge: $V_D = V_R = 0\text{V}$
	surge current	12300 A	$t_p = 8.3\text{ ms}$	
$I^2t$	Limiting load integral	673 $\text{kA}^2\text{s}$	$t_p = 10\text{ ms}$	
		628 $\text{kA}^2\text{s}$	$t_p = 8.3\text{ ms}$	
$V_T$	On-state voltage	2.25 V	$I_T = 1000\text{ A}$	$T_j = 125^\circ\text{C}$
$V_{T0}$	Threshold voltage	1.22 V	$I_T = 600 - 1800\text{ A}$	
$r_T$	Slope resistance	0.970 $\text{m}\Omega$		
$I_H$	Holding current	40-90 mA	$T_j = 25^\circ\text{C}$	
		15-60 mA	$T_j = 125^\circ\text{C}$	
$I_L$	Latching current	100- mA	$T_j = 25^\circ\text{C}$	
		50-200 mA	$T_j = 125^\circ\text{C}$	

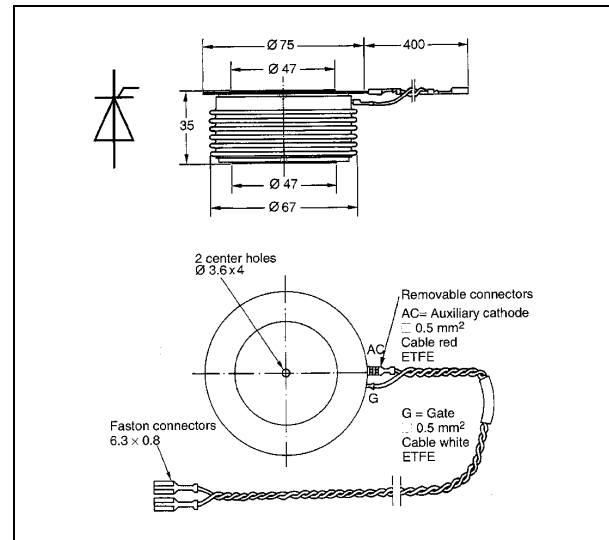
**Switching**

$di/dt_{crit}$	Critical rate of rise of on-state current	100 $\text{A}/\mu\text{s}$	Cont. $f = 50\text{ Hz}$	$V_D \leq 0.67 \cdot V_{DRM}$ , $T_j = 125^\circ\text{C}$ $I_{TRM} = 2000\text{ A}$ $I_{FG} = 2\text{ A}$ , $t_r = 0.5\ \mu\text{s}$
		200 $\text{A}/\mu\text{s}$	60 sec. $f = 50\text{ Hz}$	
$t_d$	Delay time	$\leq 3.0\ \mu\text{s}$	$V_D = 0.4 \cdot V_{DRM}$	$I_{FG} = 2\text{ A}$ , $t_r = 0.5\ \mu\text{s}$
$t_q$	Turn-off time	$\leq 700\ \mu\text{s}$	$V_D \leq 0.67 \cdot V_{DRM}$ $dv_D/dt = 20\text{V}/\mu\text{s}$	$I_{TRM} = 2000\text{ A}$ , $T_j = 125^\circ\text{C}$ $V_R > 200\text{ V}$ , $di_T/dt = -1\text{ A}/\mu\text{s}$
$Q_{rr}$	Recovery charge	min	1600 $\mu\text{As}$	
		max	2700 $\mu\text{As}$	

**Triggering**

$V_{GT}$	Gate trigger voltage	2.6 V	$T_j = 25^\circ$
$I_{GT}$	Gate trigger current	400 mA	$T_j = 25^\circ$
$V_{GD}$	Gate non-trigger voltage	0.3 V	$V_D = 0.4 \times V_{DRM}$
$I_{GD}$	Gate non-trigger current	10 mA	$V_D = 0.4 \times V_{DRM}$
$V_{FGM}$	Peak forward gate voltage	12 V	
$I_{FGM}$	Peak forward gate current	10 A	
$V_{RGM}$	Peak reverse gate voltage	10 V	
$P_G$	Gate power loss	3 W	

### Thermal

T <sub>Jmax</sub>	Max. operating junction temperature range	125 °C	
T <sub>stg</sub>	Storage temperature range	-40...140 °C	
R <sub>thJC</sub>	Thermal resistance junction to case	43 K/kW	Anode side cooled
		45 K/kW	Cathode side cooled
		22 K/kW	Double side cooled
R <sub>thCH</sub>	Thermal resistance case to heat sink	8 K/kW	Single side cooled
		4 K/kW	Double side cooled

Analytical function for transient thermal impedance:

$$Z_{thJC}(t) = \sum_{i=1}^n R_i(1 - e^{-t/\tau_i})$$

i	1	2	3	4
R <sub>i</sub> (K/kW)	13.62	5.23	1.52	1.46
τ <sub>i</sub> (s)	0.6894	0.0824	0.017	0.0077

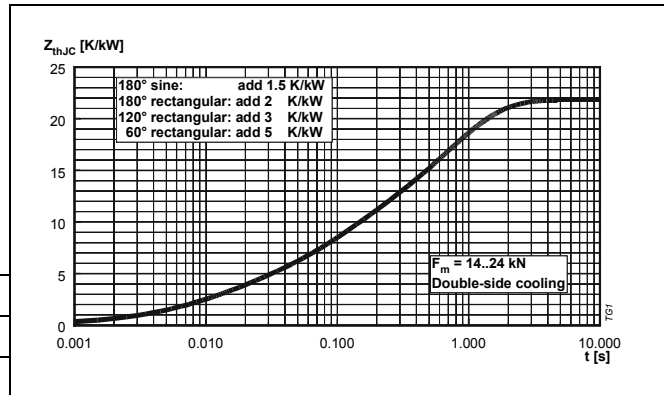

Fig. 1 Transient thermal impedance junction to case.

On-state characteristic model:

$$VT = A + B \cdot iT + C \cdot \ln(iT + 1) + D \cdot \sqrt{IT}$$

Valid for i<sub>T</sub> = 400 – 3000 A

A	B	C	D
-2.676495	0.00153	0.922004	-0.09435

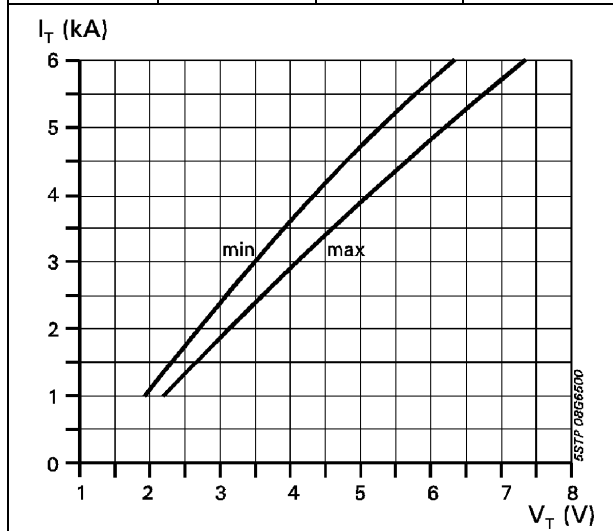

Fig. 2 On-state characteristics. T<sub>J</sub>=125°C, 10ms half sine

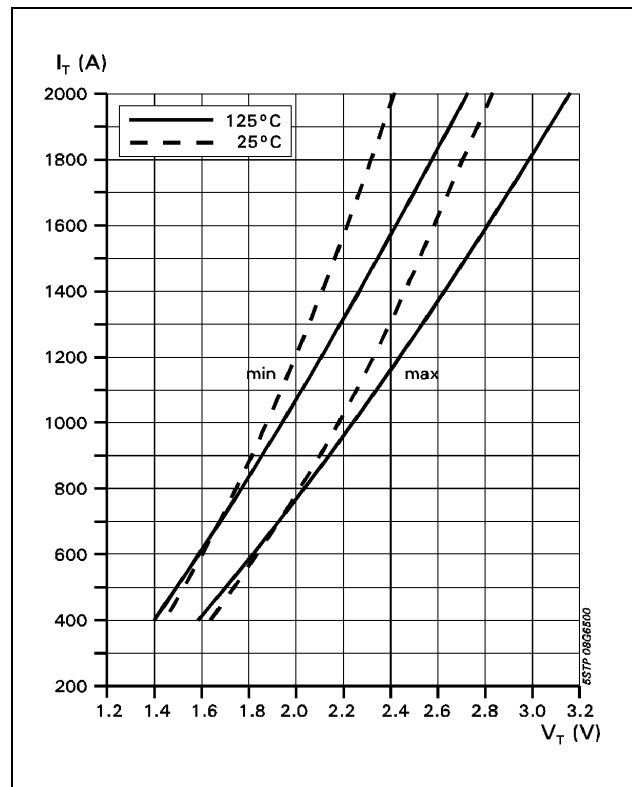

Fig. 3 On-state characteristics.

ABB Semiconductors AG reserves the right to change specifications without notice.

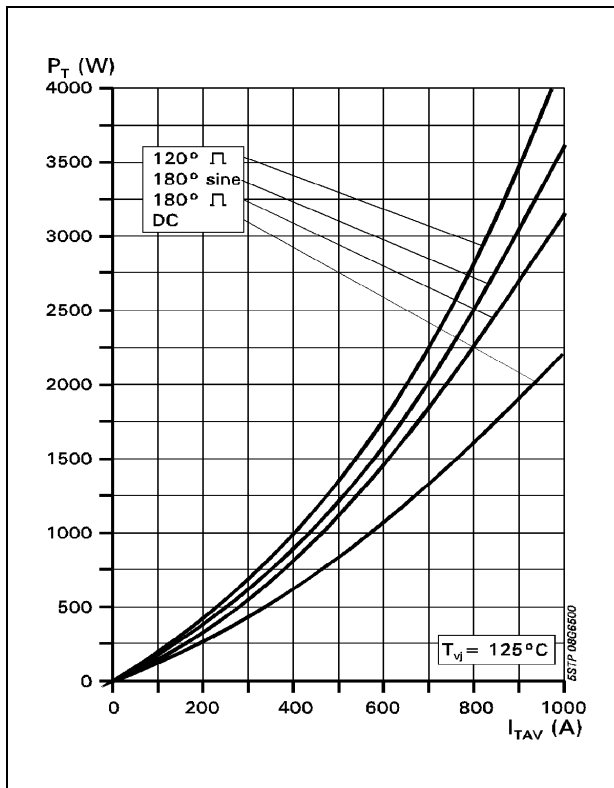

Fig. 4 On-state power dissipation vs. mean on-state current. Turn - on losses excluded.

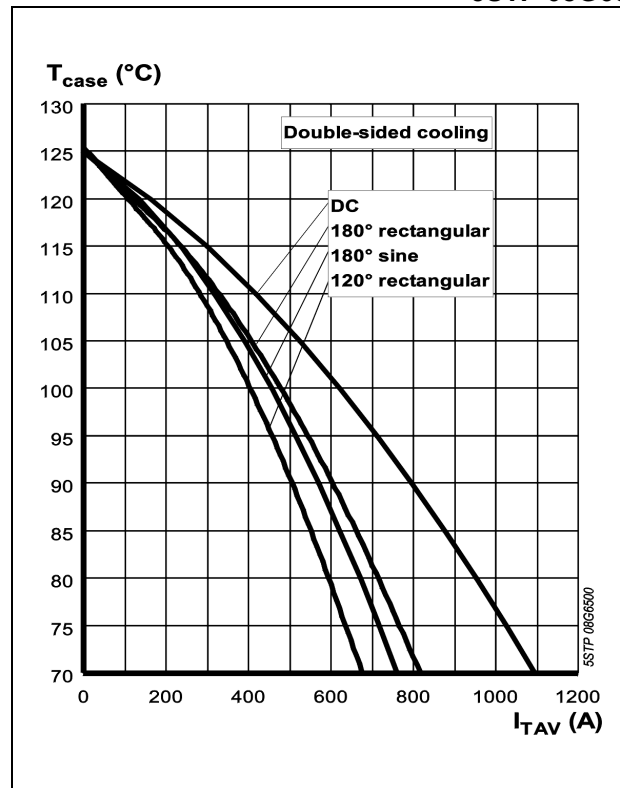

Fig. 5 Max. permissible case temperature vs. mean on-state current.

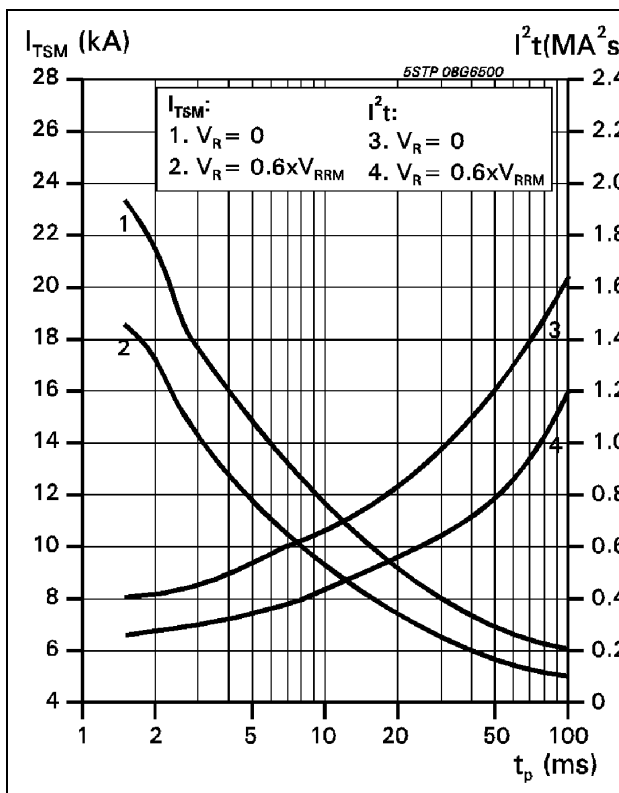

Fig. 6 Surge on-state current vs. pulse length. Half-sine wave.

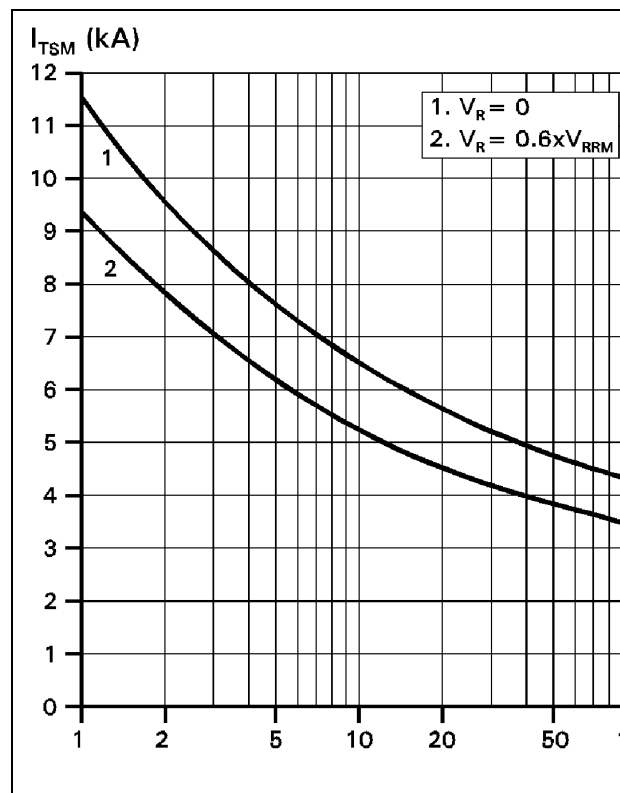

Fig. 7 Surge on-state current vs. number of pulses. Half-sine wave, 10 ms, 50Hz.

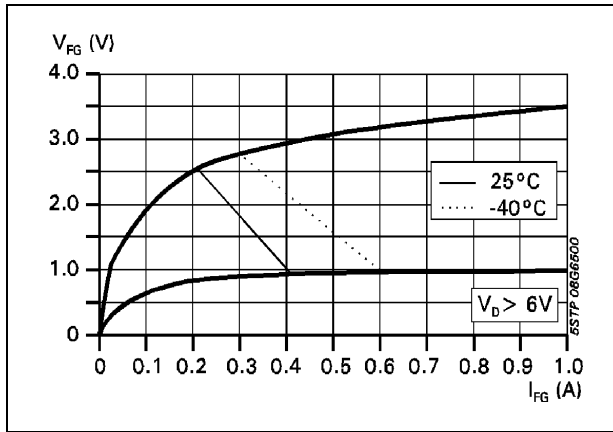

Fig. 8 Gate trigger characteristics.

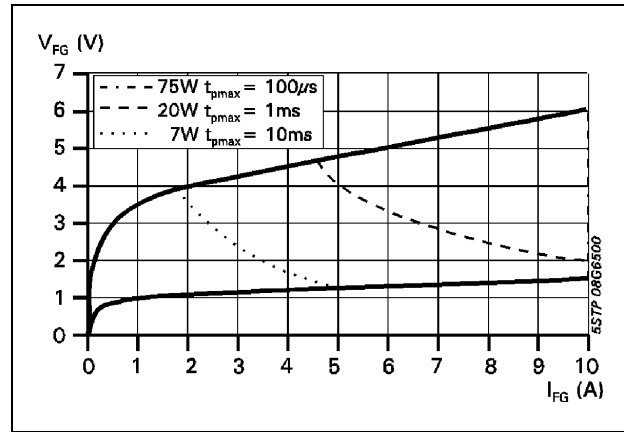

Fig. 9 Max. peak gate power loss.

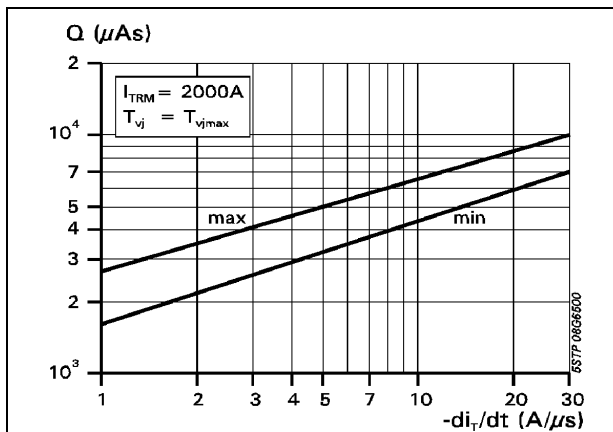

Fig. 10 Recovery charge vs. decay rate of on-state current.

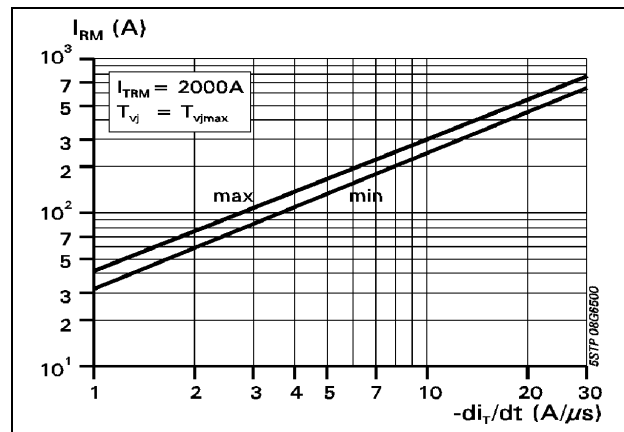

Fig. 11 Peak reverse recovery current vs. decay rate of on-state current.

### Turn - off time, typical parameter relationship.

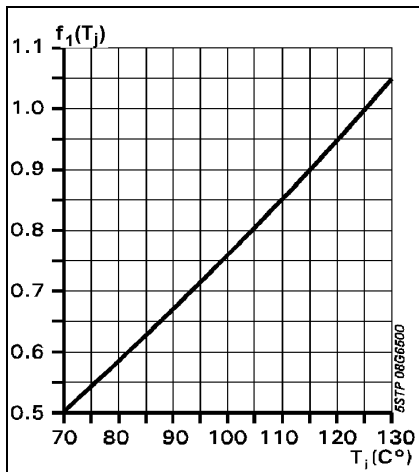

Fig. 12  $t_q/t_{q1} = f_1(T_j)$

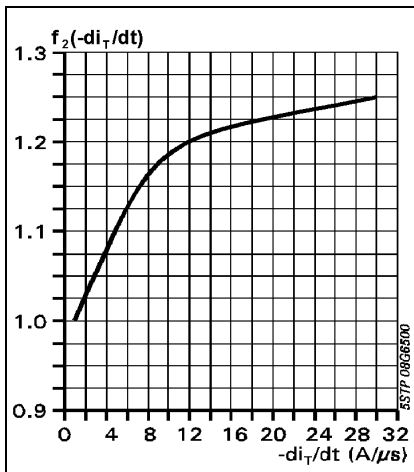

Fig. 13  $t_q/t_{q1} = f_2(-di_T/dt)$

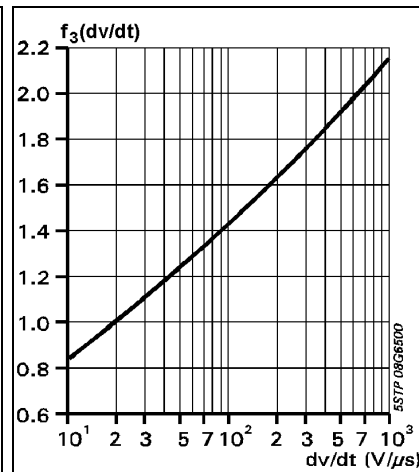

Fig. 14  $t_q/t_{q1} = f_3(dv/dt)$

$$t_q = t_{q1} \cdot f_1(T_j) \cdot f_2(-di_T/dt) \cdot f_3(dv/dt)$$

$t_{q1}$  : at normalized values (see page 2)  
 $t_q$  : at varying conditions

## Turn-on and Turn-off losses

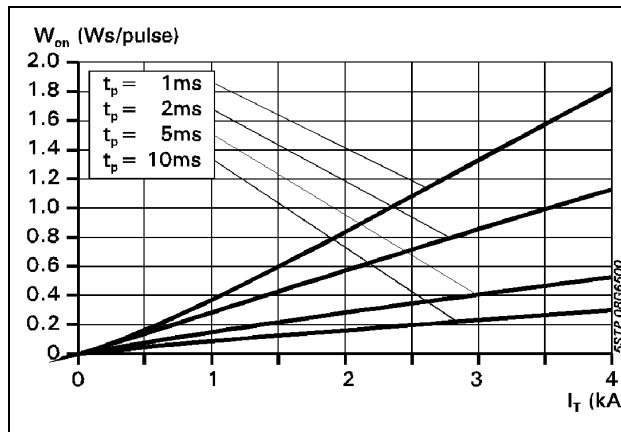

Fig. 15  $W_{on} = f(I_T, t_p)$ ,  $T_j = 125^\circ\text{C}$ .  
Half sinusoidal waves.

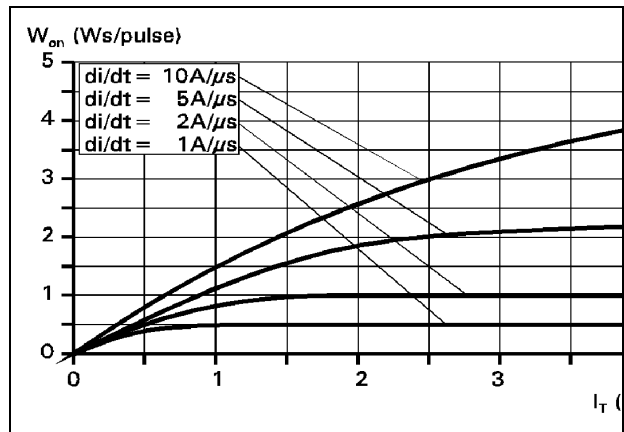

Fig. 16  $W_{on} = f(I_T, di/dt)$ ,  $T_j = 125^\circ\text{C}$ .  
Rectangular waves.

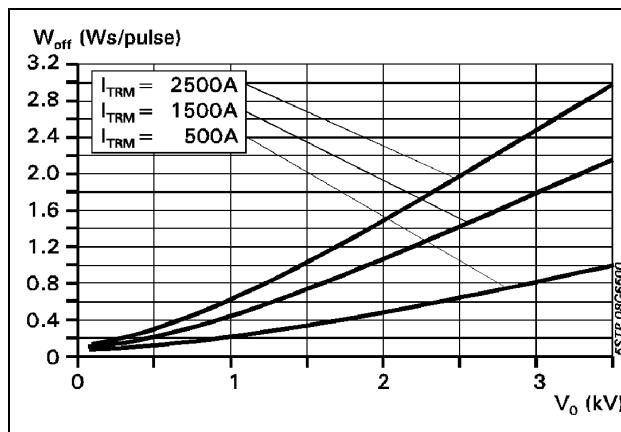

Fig. 17  $W_{off} = f(V_o, I_T)$ ,  $T_j = 125^\circ\text{C}$ .  
Half sinusoidal waves.  $t_p = 10\text{ ms}$ .

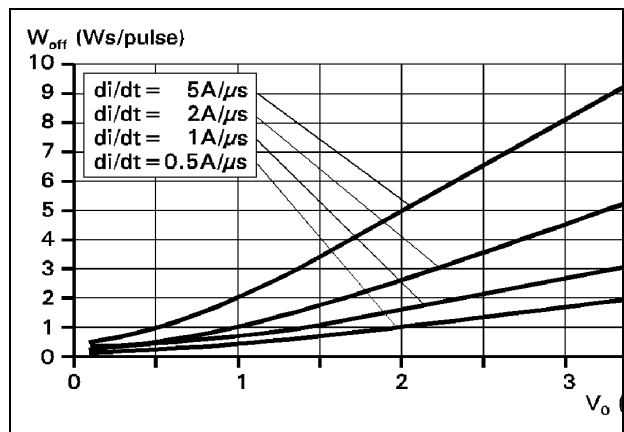

Fig. 18  $W_{off} = f(V_o, di/dt)$ ,  $T_j = 125^\circ\text{C}$ .  
Rectangular waves.



ABB Semiconductors AG reserves the right to change specifications without notice.



ABB Semiconductors AG  
Fabrikstrasse 3  
CH-5600 Lenzburg, Switzerland

Telephone +41 (0)62 888 6419  
Fax +41 (0)62 888 6306  
Email [abbsem@ch.abb.com](mailto:abbsem@ch.abb.com)  
Internet [www.abbsem.com](http://www.abbsem.com)

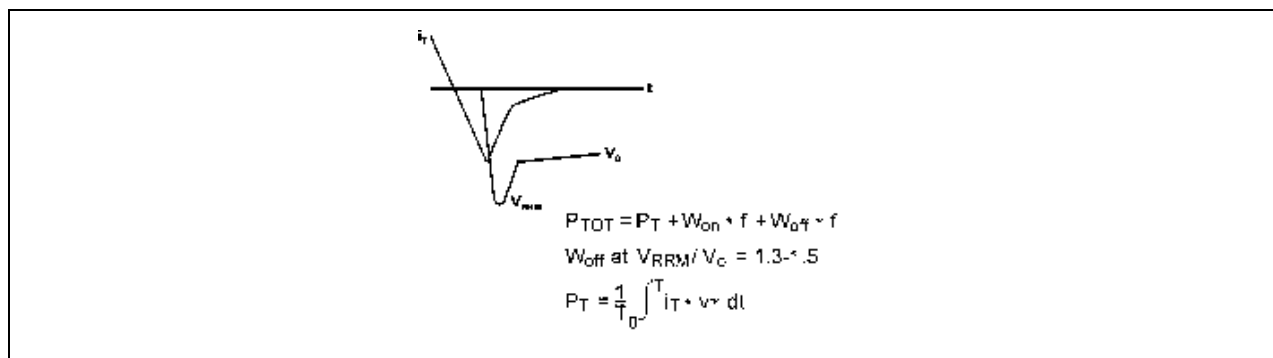
Doc. No. 5SYA1006-03 Sep. 01