

The RF Line Microwave Pulse Power Transistors

Designed for Class A and AB common emitter amplifier applications in the low-power stages of IFF, DME, TACAN, radar transmitters, and CW systems.

- Guaranteed Performance @ 1090 MHz, 18 Vdc — Class A
Output Power = 0.2 Watt
Minimum Gain = 10 dB
- 100% Tested for Load Mismatch at All Phase Angles with 10:1 VSWR
- Industry Standard Package
- Nitride Passivated
- Gold Metallized, Emitter Ballasted for Long Life and Resistance to Metal Migration
- Internal Input Matching for Broadband Operation

MRF1000MB

**0.7 W, 960–1215 MHz
CLASS A/AB
MICROWAVE POWER
TRANSISTORS
NPN SILICON**

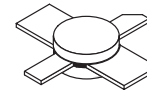

CASE 332A-03, STYLE 2

MAXIMUM RATINGS

Rating	Symbol	Value	Unit
Collector–Emitter Voltage	V_{CEO}	20	Vdc
Collector–Base Voltage	V_{CBO}	50	Vdc
Emitter–Base Voltage	V_{EBO}	3.5	Vdc
Collector Current — Continuous	I_C	200	mAdc
Total Device Dissipation @ $T_C = 25^\circ\text{C}$ (1) Derate above 25°C	P_D	7.0 40	Watts mW/ $^\circ\text{C}$
Storage Temperature Range	T_{stg}	-65 to +150	$^\circ\text{C}$

THERMAL CHARACTERISTICS

Characteristic	Symbol	Max	Unit
Thermal Resistance, Junction to Case (2)	$R_{\theta JC}$	25	$^\circ\text{C}/\text{W}$

ELECTRICAL CHARACTERISTICS ($T_C = 25^\circ\text{C}$ unless otherwise noted.)

Characteristic	Symbol	Min	Typ	Max	Unit
----------------	--------	-----	-----	-----	------

OFF CHARACTERISTICS

Collector–Emitter Breakdown Voltage ($I_C = 5.0$ mAdc, $I_E = 0$)	$V_{(BR)CEO}$	20	—	—	Vdc
Collector–Emitter Breakdown Voltage ($I_C = 5.0$ mAdc, $V_{BE} = 0$)	$V_{(BR)CES}$	50	—	—	Vdc
Collector–Base Breakdown Voltage ($I_C = 5.0$ mAdc, $I_E = 0$)	$V_{(BR)CBO}$	50	—	—	Vdc
Emitter–Base Breakdown Voltage ($I_E = 1.0$ mAdc, $I_C = 0$)	$V_{(BR)EBO}$	3.5	—	—	Vdc
Collector Cutoff Current ($V_{CB} = 20$ Vdc, $I_E = 0$)	I_{CBO}	—	—	0.5	mAdc

ON CHARACTERISTICS

DC Current Gain ($I_C = 100$ mAdc, $V_{CE} = 5.0$ Vdc)	h_{FE}	10	—	100	—
--	----------	----	---	-----	---

1. These devices are designed for RF operation. The total device dissipation rating applies only when the device is operated as RF amplifiers.
2. Thermal Resistance is determined under specified RF operating conditions by infrared measurement techniques.

Replaces MRF1000MA/D

tyco / Electronics

M/A-COM

ELECTRICAL CHARACTERISTICS — continued ($T_C = 25^\circ\text{C}$ unless otherwise noted.)

Characteristic	Symbol	Min	Typ	Max	Unit
DYNAMIC CHARACTERISTICS					
Output Capacitance ($V_{CE} = 28\text{ Vdc}$, $I_E = 0$, $f = 1.0\text{ MHz}$)	C_{ob}	—	2.0	5.0	pF
FUNCTIONAL TESTS					
Common-Emitter Power Gain — Class A ($V_{CE} = 18\text{ Vdc}$, $I_C = 100\text{ mA}$, $f = 1090\text{ MHz}$, $P_{out} = 200\text{ mW}$)	G_{PE}	10	12	—	dB
Common-Emitter Power Gain — Class AB ($V_{CE} = 18\text{ Vdc}$, $I_{CQ} = 10\text{ mA}$, $f = 1090\text{ MHz}$, $P_{out} = 0.7\text{ W}$)	G_{PE}	—	10.7	—	dB
Load Mismatch — Class A ($V_{CE} = 18\text{ Vdc}$, $I_C = 100\text{ mA}$, $f = 1090\text{ MHz}$, $P_{out} = 200\text{ mW}$, VSWR = 10:1 All Phase Angles)	ψ	No Degradation in Power Output			

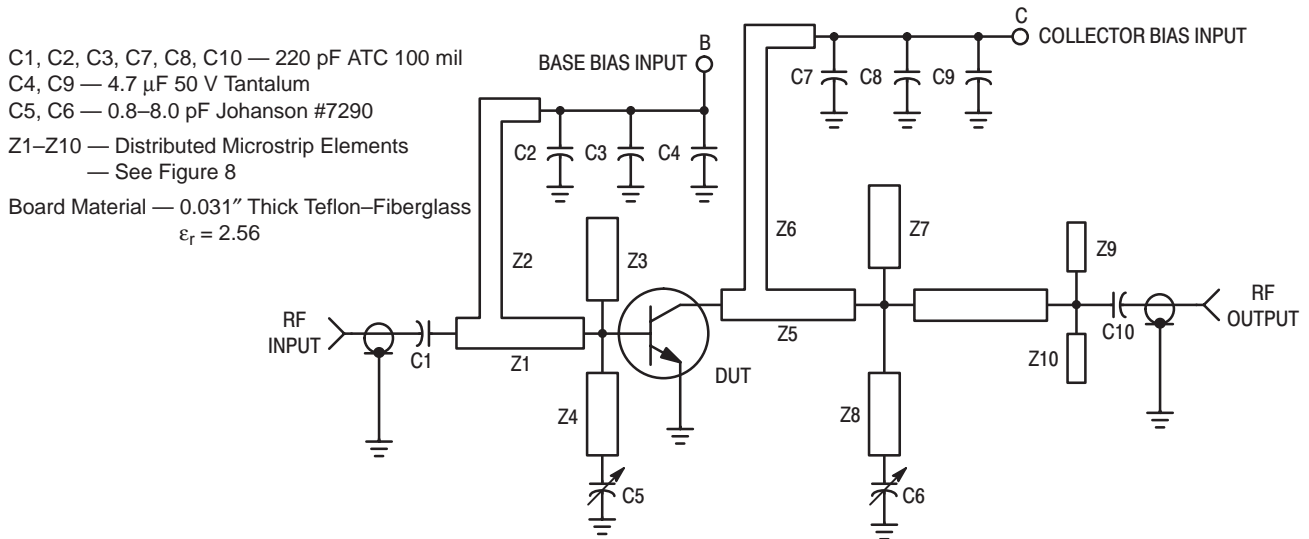

Class AB Bias Control Circuit
 18 V Output I_{CQ} 10 mA Nominal

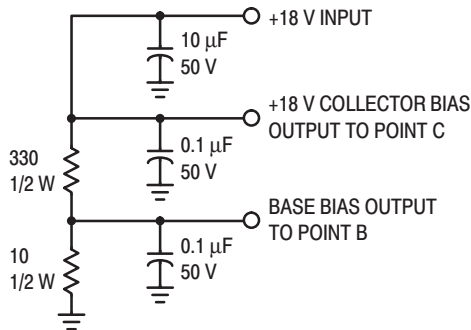

Class A Constant Current Bias Control Circuit
 $I_C = 100\text{ mA}$, $V_{CE} = 18\text{ V}$

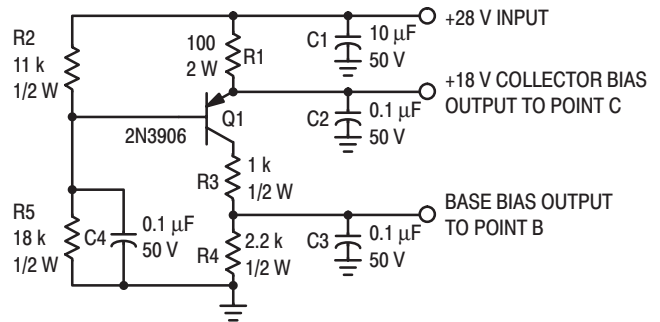

Figure 1. 1090 MHz Test Circuit

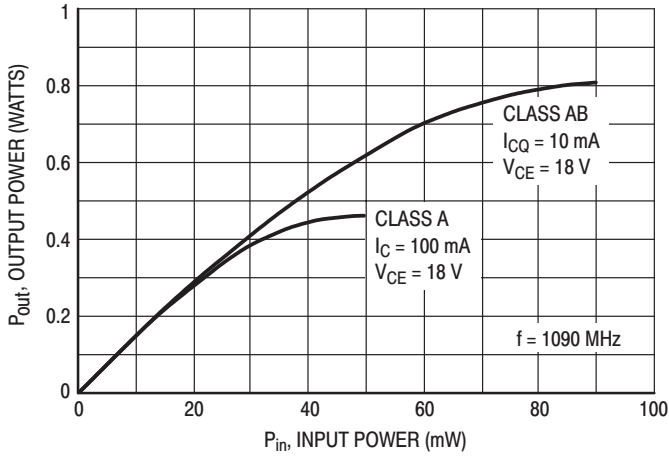

Figure 2. Output Power versus Input Power

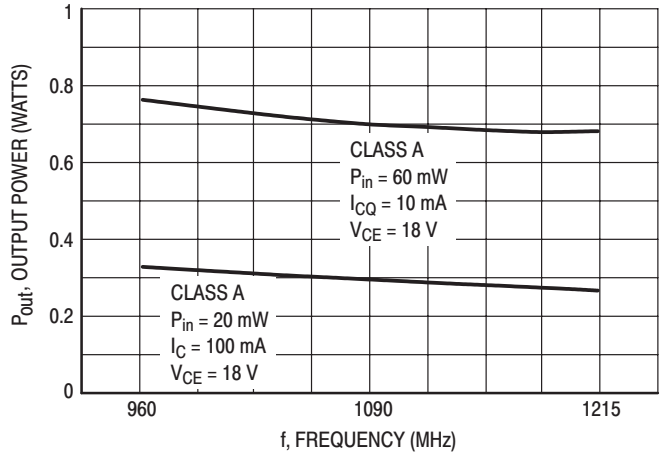

Figure 3. Output Power versus Frequency

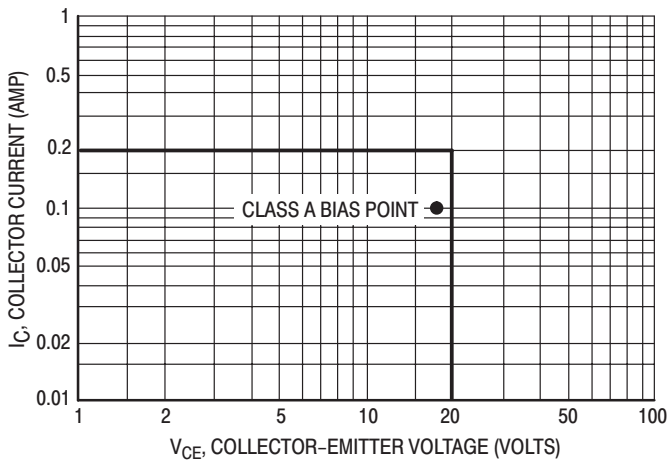

Figure 4. DC Safe Operating Area

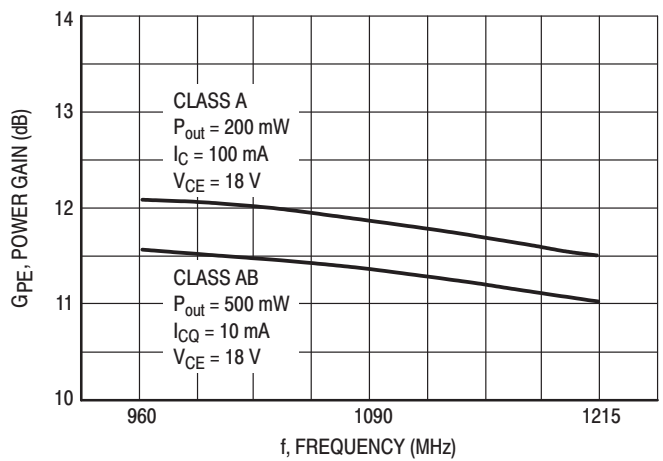
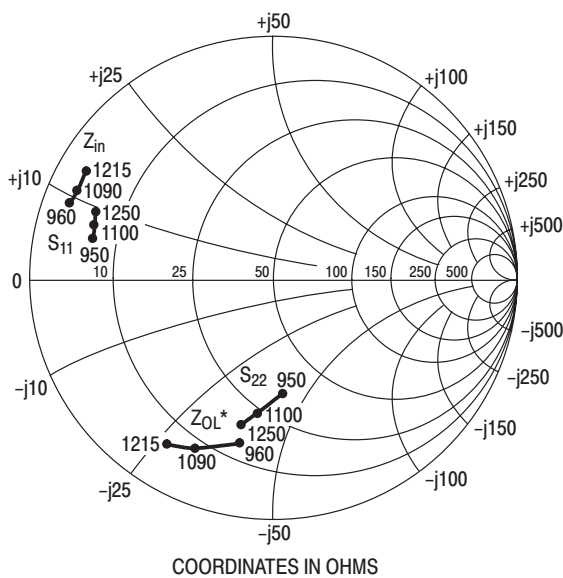

Figure 5. Power Gain versus Frequency



SERIES EQUIVALENT IMPEDANCES

$P_{out} = 0.5 \text{ W}$, $V_{CE} = 18 \text{ Vdc}$,
 $I_{CQ} = 10 \text{ mA}$, Class AB

f MHz	Z_{in} Ohms	Z_{OL}^* Ohms
960	$3.0 + j9.0$	$16 - j40$
1090	$3.2 + j10$	$8.5 - j31$
1215	$2.8 + j12$	$7.0 - j26$

Z_{OL}^* = Conjugate of the optimum load impedance into which the device output operates at a given output power, voltage, and frequency.

S-PARAMETERS — $V_{CE} = 18 \text{ Vdc}$, $I_C = 100 \text{ mA}$, Class A

f (MHz)	S_{11}		S_{21}		S_{12}		S_{22}	
	$ S_{11} $	$\angle \phi$	$ S_{21} $	$\angle \phi$	$ S_{12} $	$\angle \phi$	$ S_{22} $	$\angle \phi$
950	0.77	166	2.42	40	0.016	42	0.48	-87
1000	0.78	165	2.36	38	0.016	48	0.50	-90
1050	0.77	163	2.31	33	0.016	46	0.51	-94
1100	0.77	162	2.31	28	0.016	46	0.54	-97
1150	0.78	161	2.20	23	0.015	46	0.57	-100
1200	0.78	159	2.20	19	0.016	47	0.59	-103
1250	0.78	158	2.12	12	0.016	42	0.61	-106

Figure 6. Common-Emitter S-Parameters and Series Equivalent Input/Output Impedances

PACKAGE DIMENSIONS

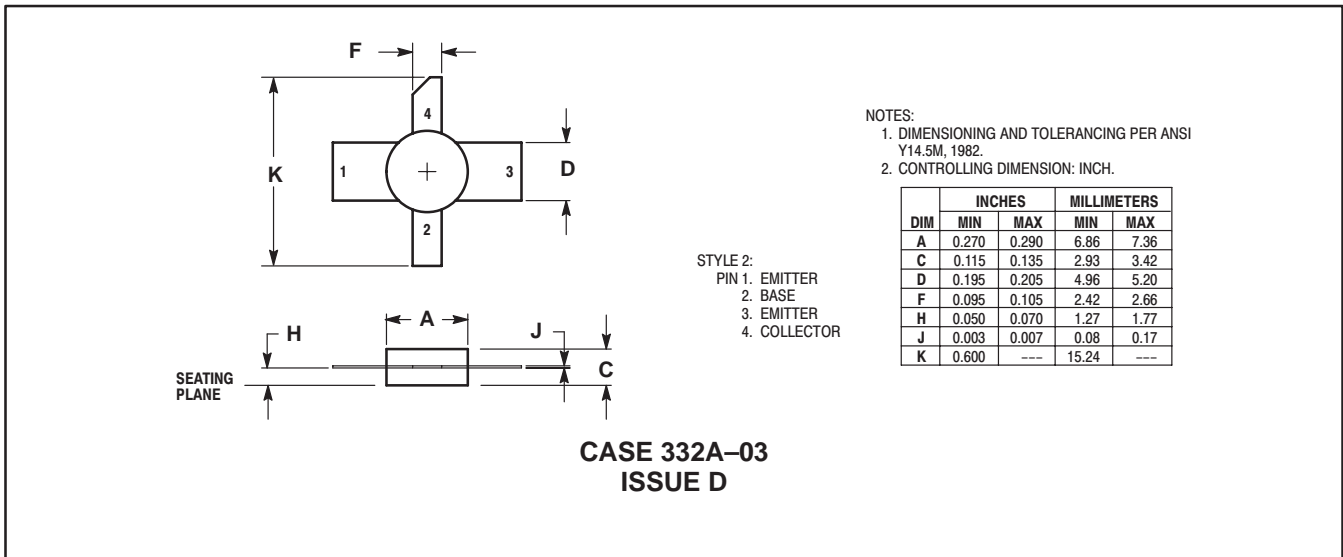

Specifications subject to change without notice.

- **North America:** Tel. (800) 366-2266, Fax (800) 618-8883
- **Asia/Pacific:** Tel.+81-44-844-8296, Fax +81-44-844-8298
- **Europe:** Tel. +44 (1344) 869 595, Fax+44 (1344) 300 020

Visit www.macom.com for additional data sheets and product information.

Replaces MRF1000MA/D

tyco / Electronics

MACOM