



RS-485 Transceiver with Integrated Low-Dropout Regulator and AutoDirection Control

General Description

The MAX13410E–MAX13415E are half-duplex RS-485-/RS-422-compatible transceivers optimized for isolated applications. These devices feature an internal low-dropout regulator (LDO), one driver, and one receiver. The internal LDO allows the part to operate from an unregulated power supply of up to 28V. The AutoDirection feature reduces the number of optical isolators needed in isolated applications. Other features include enhanced ESD protection, fail-safe circuitry, slew-rate limiting, and full-speed operation.

The MAX13410E–MAX13415E internal LDO generates a $5V \pm 10\%$ power supply that is used to power its internal circuitry. The MAX13412E–MAX13415E bring the 5V to an output VREG that allows the user to power additional external circuitry with up to 20mA to further reduce external components. The MAX13410E/MAX13411E do not have a 5V output and come in industry-compatible pinouts. This allows easy replacement in existing designs.

The MAX13410E–MAX13415E feature a 1/8-unit load receiver input impedance, allowing up to 256 transceivers on the bus. All driver outputs are ESD protected using the Human Body Model. These devices also include fail-safe circuitry (MAX13410E/MAX13411E/MAX13414E/MAX13415E only), guaranteeing a logic-high receiver output when the receiver inputs are open or shorted. The receiver outputs a logic-high when the transmitter on the terminated bus is disabled (high impedance).

The MAX13412E/MAX13413E feature Maxim's proprietary AutoDirection control. This architecture eliminates the need for the DE and RE control signals. In isolated applications, this reduces the cost and size of the system by reducing the number of optical isolators required.

The MAX13410E/MAX13412E/MAX13414E feature reduced slew-rate drivers that minimize EMI and reduce reflections caused by improperly terminated cables, allowing error-free transmission up to 500kbps. The MAX13411E/MAX13413E/MAX13415E are not slew-rate limited, allowing transmit speeds up to 16Mbps.

The MAX13410E–MAX13415E are available in an 8-pin SO package with an exposed paddle to improve power dissipation, and operate over the extended -40°C to $+85^{\circ}\text{C}$ temperature range.

Features

- ◆ Wide +6V to +28V Input Supply Range
- ◆ +5V Output Supplies Up to 20mA to External Circuitry
- ◆ Internal LDO
- ◆ Low 65 μA (typ) Shutdown Supply Current
- ◆ Extended ESD Protection
 - ±15kV Human Body Model (MAX13412E/MAX13413E)
 - ±14kV Human Body Model (MAX13410E/MAX13411E)
- ◆ 1/8-Unit Load, Allowing Up to 256 Transceivers on the Bus
- ◆ -40°C to $+85^{\circ}\text{C}$ Operating Temperature Range
- ◆ Fail-Safe
- ◆ Slew-Rate Limited and Full-Speed Versions
- ◆ Up to 16Mbps Data Rate on Full-Speed Versions

Applications

Isolated RS-485 Interfaces Industrial Equipment
Utility Meters Telecomm Equipment

Pin Configurations

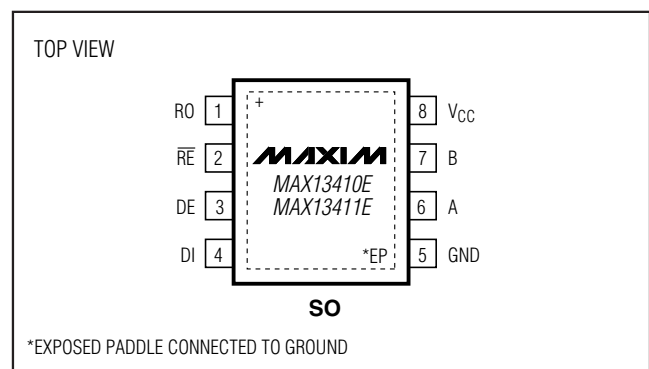

Pin Configurations continued at end of data sheet.

Ordering Information/Selector Guide

PART	PIN-PACKAGE	AutoDirection	DATA RATE (max)	SLEW-RATE LIMITED	PKG CODE
MAX13410EESA+	8 SO-EP*	No	500kbps	Yes	S8E+14
MAX13411EESA+	8 SO-EP*	No	16Mbps	No	S8E+14

Note: All devices operate over the -40°C to $+85^{\circ}\text{C}$ operating temperature range.

+Denotes a lead-free package.

*EP = Exposed paddle.

Ordering Information/Selector Guide continued at end of data sheet.



Maxim Integrated Products 1

For pricing, delivery, and ordering information, please contact Maxim Direct at 1-888-629-4642, or visit Maxim's website at www.maxim-ic.com.

MAX13410E-MAX13415E

RS-485 Transceiver with Integrated Low-Dropout Regulator and AutoDirection Control

ABSOLUTE MAXIMUM RATINGS

(All voltages referenced to GND.)

V _{CC}	-0.3V to +30V	Operating Temperature Range	-40°C to +85°C
\overline{RE} , DE/ \overline{RE} , DE, DI, RO, V _{REG}	-0.3V to +6V	Storage Temperature Range	-65°C to +150°C
A, B.....	-8V to +13V	Junction Temperature.....	+150°C
Short-Circuit Duration (RO, A, B) to GND	Continuous	θ_{JA} (Note 1).....	52.0°C/W
Continuous Power Dissipation (T _A = +70°C)		θ_{JC} (Note 1).....	6.0°C/W
8-Pin SO-EP (derate 19.2mW/°C above +70°C)	1539mW	Lead Temperature (soldering, 10s)	+300°C

Note 1: Package thermal resistances were obtained using the method described in JEDEC specifications JESD51-7 using a four layer board. For detailed information on package consistencies refer to www.maxim-ic.com/thermal-tutorial.

Stresses beyond those listed under "Absolute Maximum Ratings" may cause permanent damage to the device. These are stress ratings only, and functional operation of the device at these or any other conditions beyond those indicated in the operational sections of the specifications is not implied. Exposure to absolute maximum rating conditions for extended periods may affect device reliability.

ELECTRICAL CHARACTERISTICS

(V_{CC} = +6.0V to +28V, T_A = T_{MIN} to T_{MAX}, unless otherwise noted. Typical values are at V_{CC} = +7.5V, C_S = 1 μ F, and T_A = +25°C.) (Note 2)

PARAMETER	SYMBOL	CONDITIONS	MIN	TYP	MAX	UNITS
Supply Voltage	V _{CC}	(Note 3)	6.0		28.0	V
LDO Output Voltage	V _{REG}	V _{CC} = +7.5V, I _{LOAD} = 20mA	4.5	5	5.5	V
		V _{CC} = +28V, I _{LOAD} = 0mA	4.5	5	5.5	
LDO Output Current	I _{REG}	V _{CC} > +7.5V			20	mA
LDO Dropout Voltage	V _{DO}	V _{CC} = +5V, I _{OUT} = 20mA		0.5		V
Minimum Bypass Capacitor on V _{REG}	C _S	Guaranteed by design, MAX13412E-MAX13415E	1			μ F
Supply Current	I _{CC}	\overline{RE} , DE = high/no load (MAX13410E/MAX13411E)			10	mA
		\overline{RE} , DE/ \overline{RE} = high, DI = low/no load (MAX13412E-MAX13415E)			10	
Shutdown Current	I _{SHDN}	DE = low, \overline{RE} = high (MAX13410E/MAX13411E)		45		μ A
Thermal-Shutdown Threshold	T _{TS}			+150		°C
Thermal-Shutdown Threshold Hysteresis	T _{TSH}			15		°C
DRIVER						
Differential Driver Output	V _{OD}	R _{DIFF} = 100 Ω , Figure 1	2.0		5.5	V
		R _{DIFF} = 54 Ω , Figure 1	1.5		5.5	
		No load			5.5	
Change in Magnitude of Differential Output Voltage	Δ V _{OD}	R _{DIFF} = 100 Ω or 54 Ω , Figure 1			0.2	V
Driver Common-Mode Output Voltage	V _{OC}	R _{DIFF} = 100 Ω or 54 Ω , Figure 1	1		3	V
Change In Magnitude of Common-Mode Voltage	Δ V _{OC}	R _{DIFF} = 100 Ω or 54 Ω , Figure 1			0.2	V
Input High Voltage	V _{IH}	DI, DE, \overline{RE} , DE/ \overline{RE}	2.0			V
Input Low Voltage	V _{IL}	DI, DE, \overline{RE} , DE/ \overline{RE}			0.8	V
Input Current	I _{IN}	DI, DE, \overline{RE} , DE/ \overline{RE}			\pm 1	μ A
Driver-Disable Threshold	V _{DT}	T _A = +25°C (MAX13412E/MAX13413E)	0.6		1.0	V

RS-485 Transceiver with Integrated Low-Dropout Regulator and AutoDirection Control

MAX13410E-MAX13415E

ELECTRICAL CHARACTERISTICS (continued)

(V_{CC} = +6.0V to +28V, T_A = T_{MIN} to T_{MAX}, unless otherwise noted. Typical values are at V_{CC} = +7.5V, C_S = 1μF, and T_A = +25°C.) (Note 2)

PARAMETER	SYMBOL	CONDITIONS	MIN	TYP	MAX	UNITS
Driver Short-Circuit Output Current	I _{OSD}	0V ≤ V _{OUT} ≤ +12V			+250	mA
		-7V ≤ V _{OUT} ≤ 0V	-250			
Driver Short-Circuit-Foldback Output Current	I _{OSDF}	(V _{CC} - 1V) ≤ V _{OUT} ≤ +12V	20			mA
		-7V ≤ V _{OUT} ≤ 0V			-20	
RECEIVER						
Input Current (A and B)	I _{A, B}	RE, DE, DE/RE = GND, V _{CC} = GND	V _{IN} = +12V		125	μA
			V _{IN} = -7V	-100		
Receiver Differential Threshold Voltage	V _{TH}	-7V ≤ V _{CM} ≤ +12V (MAX13410E/MAX13411E)	-200		-50	mV
		-7V ≤ V _{LM} ≤ +12V (MAX13412E/MAX13413E)	-100		100	
Receiver Input Hysteresis	ΔV _{TH}	V _A + V _B = 0V		15		mV
Output High Voltage	V _{OH}	I _O = -1mA, V _A - V _B ≥ V _{TH}	V _{REG} - 0.6			V
Output Low Voltage	V _{OL}	I _O = +1mA, V _A - V _B ≤ -V _{TH}			0.4	V
Three-State Output Current at Receiver	I _{OZR}	0 ≤ V _O ≤ V _{REG}		0.01	±1	μA
Receiver-Input Resistance	R _{IN}	-7V ≤ V _{CM} ≤ +12V	96			kΩ
Receiver-Output Short-Circuit Current	I _{OSR}	0V ≤ V _{RO} ≤ V _{REG}	±8		±95	mA
ESD PROTECTION						
ESD Protection (A, B)		Human Body Model (MAX13412E/MAX13413E)		±15		kV
ESD Protection (A, B)		Human Body Model (MAX13410E/MAX13411E)		±14		kV
ESD Protection (All Other Pins)		Human Body Model		±2		kV

SWITCHING CHARACTERISTICS—MAX13410E

(V_{CC} = +6.0V to +28V, T_A = T_{MIN} to T_{MAX}, unless otherwise noted. Typical values are at V_{CC} = +7.5V, C_S = 1μF, and T_A = +25°C.) (Note 2)

PARAMETER	SYMBOL	CONDITIONS	MIN	TYP	MAX	UNITS
DRIVER						
Driver Propagation Delay	t _{DPLH}	R _{DIFF} = 54Ω, C _L = 50pF, Figures 2a and 3a	150		1000	ns
	t _{DPHL}		150		1000	
Driver Differential Output Rise or Fall Time	t _{HL}	R _{DIFF} = 54Ω, C _L = 50pF, Figures 2a and 3a	250		900	ns
	t _{LH}		250		900	
Driver Differential Output Skew t _{DPLH} - t _{DPHL}	t _{DSKEW}	R _{DIFF} = 54Ω, C _L = 50pF, Figures 2a and 3a			140	ns
Maximum Data Rate	f _{MAX}		500			kbps
Driver Enable from Shutdown to Output High	t _{DZH(SHDN)}	S2 closed, Figure 4, R _L = 500Ω, C _L = 100pF			11	μs
Driver Enable from Shutdown to Output Low	t _{DZL(SHDN)}	S2 closed, Figure 4, R _L = 500Ω, C _L = 100pF			6	μs

RS-485 Transceiver with Integrated Low-Dropout Regulator and AutoDirection Control

SWITCHING CHARACTERISTICS—MAX13410E (continued)

($V_{CC} = +6.0V$ to $+28V$, $T_A = T_{MIN}$ to T_{MAX} , unless otherwise noted. Typical values are at $V_{CC} = +7.5V$, $C_S = 1\mu F$, and $T_A = +25^\circ C$.) (Note 2)

PARAMETER	SYMBOL	CONDITIONS	MIN	TYP	MAX	UNITS
Driver Enable to Output High	t_{DZH}	S2 closed, Figure 4, $R_L = 500\Omega$, $C_L = 100pF$			2500	ns
Driver Enable to Output Low	t_{DZL}	S1 closed, Figure 4, $R_L = 500\Omega$, $C_L = 100pF$			2500	ns
Driver Disable from Output High	t_{DZH}	S2 closed, Figure 4, $R_L = 500\Omega$, $C_L = 100pF$			100	ns
Driver Disable from Output Low	t_{DLZ}	S1 closed, Figure 4, $R_L = 500\Omega$, $C_L = 100pF$			100	ns
Time to Shutdown	t_{SHDN}		50	340	700	ns
RECEIVER						
Receiver Propagation Delay	t_{RPLH}	$C_L = 15pF$ (at RO), Figures 5 and 6			200	ns
	t_{RPHL}				200	
Receiver Output Skew	t_{RSKEW}	$C_L = 15pF$ (at RO), Figures 5 and 6			30	ns
Maximum Data Rate	f_{MAX}		500			kbps
Receiver Enable to Output High	t_{RZH}	S2 closed, Figure 7, $C_L = 15pF$			50	ns
Receiver Enable to Output Low	t_{RZL}	S1 closed, Figure 7, $C_L = 15pF$			50	ns
Receiver Disable Time from High	t_{RZH}	S2 closed, Figure 7, $C_L = 15pF$			50	ns
Receiver Disable Time from Low	t_{RLZ}	S1 closed, Figure 7, $C_L = 15pF$			50	ns
Receiver Enable from Shutdown to Output High	$t_{RZH(SHDN)}$	S2 closed, Figure 7, $C_L = 15pF$			14	μs
Receiver Enable from Shutdown to Output Low	$t_{RZL(SHDN)}$	S1 closed, Figure 7, $C_L = 15pF$			3.5	μs

SWITCHING CHARACTERISTICS—MAX13411E

($V_{CC} = +6.0V$ to $+28V$, $T_A = T_{MIN}$ to T_{MAX} , unless otherwise noted. Typical values are at $V_{CC} = +7.5V$, $C_S = 1\mu F$, and $T_A = +25^\circ C$.) (Note 2)

PARAMETER	SYMBOL	CONDITIONS	MIN	TYP	MAX	UNITS
DRIVER						
Driver Propagation Delay	t_{DPLH}	$R_{DIFF} = 54\Omega$, $C_L = 50pF$, Figures 2a and 3a			50	ns
	t_{DPHL}				50	
Driver Differential Output Rise or Fall Time	t_{HL}	$R_{DIFF} = 54\Omega$, $C_L = 50pF$, Figures 2a and 3a			15	ns
	t_{LH}				15	
Driver Differential Output Skew $ t_{DPLH} - t_{DPHL} $	t_{DSKEW}	$R_{DIFF} = 54\Omega$, $C_L = 50pF$, Figures 2a and 3a			8	ns
Maximum Data Rate	f_{MAX}		16			Mbps
Driver Enable from Shutdown to Output High	$t_{DZH(SHDN)}$	S2 closed, Figure 4, $R_L = 500\Omega$, $C_L = 100pF$			11	μs
Driver Enable from Shutdown to Output Low	$t_{DZL(SHDN)}$	S2 closed, Figure 4, $R_L = 500\Omega$, $C_L = 100pF$			6	μs
Driver Enable to Output High	t_{DZH}	S2 closed, Figure 4, $R_L = 500\Omega$, $C_L = 100pF$			70	ns

RS-485 Transceiver with Integrated Low-Dropout Regulator and AutoDirection Control

MAX13410E-MAX13415E

SWITCHING CHARACTERISTICS—MAX13411E (continued)

(V_{CC} = +6.0V to +28V, T_A = T_{MIN} to T_{MAX}, unless otherwise noted. Typical values are at V_{CC} = +7.5V, C_S = 1μF, and T_A = +25°C.) (Note 2)

PARAMETER	SYMBOL	CONDITIONS	MIN	TYP	MAX	UNITS
Driver Enable to Output Low	t _{DZL}	S1 closed, Figure 4, R _L = 500Ω, C _L = 100pF			70	ns
Driver Disable from Output High	t _{DHZ}	S2 closed, Figure 4, R _L = 500Ω, C _L = 100pF			50	ns
Driver Disable from Output Low	t _{DLZ}	S1 closed, Figure 4, R _L = 500Ω, C _L = 100pF			50	ns
RECEIVER						
Receiver Propagation Delay	t _{RPLH}	C _L = 15pF (at RO), Figures 5 and 6			75	ns
	t _{RPHL}				75	
Receiver Output Skew	t _{RSKEW}	C _L = 15pF (at RO), Figures 5 and 6			8	ns
Maximum Data Rate	f _{MAX}		16			Mbps
Receiver Enable to Output High	t _{RZH}	S2 closed, Figure 7, C _L = 15pF			50	ns
Receiver Enable to Output Low	t _{RZL}	S1 closed, Figure 7, C _L = 15pF			50	ns
Receiver Disable Time from High	t _{RZH}	S2 closed, Figure 7, C _L = 15pF			50	ns
Receiver Disable Time from Low	t _{RLZ}	S1 closed, Figure 7, C _L = 15pF			50	ns
Receiver Enable from Shutdown to Output High	t _{RZH(SHDN)}	S2 closed, Figure 7, C _L = 15pF			14	μs
Receiver Enable from Shutdown to Output Low	t _{RZL(SHDN)}	S1 closed, Figure 7, C _L = 15pF			3.5	μs

SWITCHING CHARACTERISTICS—MAX13412E

(V_{CC} = +6.0V to +28V, T_A = T_{MIN} to T_{MAX}, unless otherwise noted. Typical values are at V_{CC} = +7.5V, C_S = 1μF, and T_A = +25°C.) (Note 2)

PARAMETER	SYMBOL	CONDITIONS	MIN	TYP	MAX	UNITS
DRIVER						
Driver Propagation Delay	t _{DPLH}	R _L = 110Ω, C _L = 50pF, Figures 2b and 3b	200		1000	ns
	t _{DPHL}		200		1000	
Driver Differential Output Rise or Fall Time	t _{HL}	R _L = 110Ω, C _L = 50pF, Figures 2b and 3b	250		900	ns
	t _{LH}		250		900	
Maximum Data Rate	f _{MAX}		500			kbps
Driver Disable Delay	t _{DDD}	R _L = 110Ω, C _L = 50pF, Figure 3b			2500	ns
RECEIVER						
Receiver Propagation Delay	t _{RPLH}	C _L = 15pF, Figures 5 and 6			200	ns
	t _{RPHL}				200	
Receiver Output Skew	t _{RSKEW}	C _L = 15pF, Figures 5 and 6			30	ns
Maximum Data Rate	f _{MAX}		500			kbps
Receiver Enable to Output High	t _{RZH}	S2 closed, Figure 7, C _L = 15pF			50	ns
Receiver Enable to Output Low	t _{RZL}	S1 closed, Figure 7, C _L = 15pF			50	ns

RS-485 Transceiver with Integrated Low-Dropout Regulator and AutoDirection Control

SWITCHING CHARACTERISTICS—MAX13412E (continued)

($V_{CC} = +6.0V$ to $+28V$, $T_A = T_{MIN}$ to T_{MAX} , unless otherwise noted. Typical values are at $V_{CC} = +7.5V$, $C_S = 1\mu F$, and $T_A = +25^\circ C$.) (Note 2)

PARAMETER	SYMBOL	CONDITIONS	MIN	TYP	MAX	UNITS
Receiver Disable Time from Low	t_{RLZ}	S1 closed, Figure 7, $C_L = 15pF$			50	ns
Receiver Disable Time from High	t_{RZH}	S2 closed, Figure 7, $C_L = 15pF$			50	ns
Receiver Enable Delay	t_{RED}	$R_L = 110\Omega$, $C_L = 50pF$, Figure 3			2500	ns

SWITCHING CHARACTERISTICS—MAX13413E

($V_{CC} = +6.0V$ to $+28V$, $T_A = T_{MIN}$ to T_{MAX} , unless otherwise noted. Typical values are at $V_{CC} = +7.5V$, $C_S = 1\mu F$, and $T_A = +25^\circ C$.) (Note 2)

PARAMETER	SYMBOL	CONDITIONS	MIN	TYP	MAX	UNITS
DRIVER						
Driver Propagation Delay	t_{DPLH}	$R_L = 110\Omega$, $C_L = 50pF$, Figures 2b and 3b			50	ns
	t_{DPHL}				50	
Driver Differential Output Rise or Fall Time	t_{HL}	$R_L = 110\Omega$, $C_L = 50pF$, Figures 2b and 3b			15	ns
	t_{LH}				15	
Maximum Data Rate	f_{MAX}		16			Mbps
Driver Disable Delay	t_{DDD}	$R_L = 110\Omega$, $C_L = 50pF$, Figure 3b			70	ns
RECEIVER						
Receiver Propagation Delay	t_{RPLH}	$C_L = 15pF$, Figures 5 and 6			80	ns
	t_{RPHL}				80	
Receiver Output Skew	t_{RSKEW}	$C_L = 15pF$, Figures 5 and 6			13	ns
Maximum Data Rate	f_{MAX}		16			Mbps
Receiver Enable to Output High	t_{RZH}	S2 closed, Figure 7, $C_L = 15pF$			50	ns
Receiver Enable to Output Low	t_{RZL}	S1 closed, Figure 7, $C_L = 15pF$			50	ns
Receiver Disable Time from Low	t_{RLZ}	S1 closed, Figure 7, $C_L = 15pF$			50	ns
Receiver Disable Time from High	t_{RZH}	S2 closed, Figure 7, $C_L = 15pF$			50	ns
Receiver Enable Delay	t_{RED}	$R_L = 110\Omega$, Figure 3, $C_L = 50pF$			70	ns

SWITCHING CHARACTERISTICS—MAX13414E

($V_{CC} = +6.0V$ to $+28V$, $T_A = T_{MIN}$ to T_{MAX} , unless otherwise noted. Typical values are at $V_{CC} = +7.5V$, $C_S = 1\mu F$, and $T_A = +25^\circ C$.) (Note 2)

PARAMETER	SYMBOL	CONDITIONS	MIN	TYP	MAX	UNITS
DRIVER						
Driver Propagation Delay	t_{DPLH}	$R_{DIFF} = 54\Omega$, $C_L = 50pF$, Figures 2a and 3a	200		1000	ns
	t_{DPHL}		200		1000	
Driver Differential Output Rise or Fall Time	t_{HL}	$R_{DIFF} = 54\Omega$, $C_L = 50pF$, Figures 2a and 3a	250		900	ns
	t_{LH}		250		900	
Driver Differential Output Skew $ t_{DPLH} - t_{DPHL} $	t_{DSKEW}	$R_{DIFF} = 54\Omega$, $C_L = 50pF$, Figures 2a and 3a			140	ns

RS-485 Transceiver with Integrated Low-Dropout Regulator and AutoDirection Control

MAX13410E-MAX13415E

SWITCHING CHARACTERISTICS—MAX13414E (continued)

(V_{CC} = +6.0V to +28V, T_A = T_{MIN} to T_{MAX}, unless otherwise noted. Typical values are at V_{CC} = +7.5V, C_S = 1μF, and T_A = +25°C.) (Note 2)

PARAMETER	SYMBOL	CONDITIONS	MIN	TYP	MAX	UNITS
Maximum Data Rate	f _{MAX}		500			kbps
Driver Enable to Output High	t _{DZH}	S2 closed, Figure 4, R _L = 500Ω, C _L = 100pF			2500	ns
Driver Enable to Output Low	t _{DZL}	S1 closed, Figure 4, R _L = 500Ω, C _L = 100pF			2500	ns
Driver Disable from Output High	t _{DHZ}	S2 closed, Figure 4, R _L = 500Ω, C _L = 100pF			100	ns
Driver Disable from Output Low	t _{DLZ}	S1 closed, Figure 4, R _L = 500Ω, C _L = 100pF			100	ns
RECEIVER						
Receiver Propagation Delay	t _{RPLH}	C _L = 15pF (at RO), Figures 5 and 6			200	ns
	t _{RPHL}				200	
Receiver Output Skew	t _{RSKEW}	C _L = 15pF (at RO), Figures 5 and 6			30	ns
Maximum Data Rate	f _{MAX}		500			kbps
Receiver Enable to Output High	t _{RZH}	S2 closed, Figure 7, C _L = 15pF			50	ns
Receiver Enable to Output Low	t _{RZL}	S1 closed, Figure 7, C _L = 15pF			50	ns
Receiver Disable Time from Low	t _{RLZ}	S1 closed, Figure 7, C _L = 15pF			50	ns
Receiver Disable Time from High	t _{RZH}	S2 closed, Figure 7, C _L = 15pF			50	ns

SWITCHING CHARACTERISTICS—MAX13415E

(V_{CC} = +6.0V to +28V, T_A = T_{MIN} to T_{MAX}, unless otherwise noted. Typical values are at V_{CC} = +7.5V, C_S = 1μF, and T_A = +25°C.) (Note 2)

PARAMETER	SYMBOL	CONDITIONS	MIN	TYP	MAX	UNITS
DRIVER						
Driver Propagation Delay	t _{DPLH}	R _{DIFF} = 54Ω, C _L = 50pF, Figures 2a and 3a			50	ns
	t _{DPHL}				50	
Driver Differential Output Rise or Fall Time	t _{HL}	R _{DIFF} = 54Ω, C _L = 50pF, Figures 2a and 3a			15	ns
	t _{LH}				15	
Driver Differential Output Skew t _{DPLH} - t _{DPHL}	t _{DSKEW}	R _{DIFF} = 54Ω, C _L = 50pF, Figures 2a and 3a			8	ns
Maximum Data Rate	f _{MAX}		16			Mbps
Driver Enable to Output High	t _{DZH}	S2 closed, Figure 4, R _L = 500Ω, C _L = 15pF			70	ns
Driver Enable to Output Low	t _{DZL}	S1 closed, Figure 4, R _L = 500Ω, C _L = 15pF			70	ns
Driver Disable from Output High	t _{DHZ}	S2 closed, Figure 4, R _L = 500Ω, C _L = 15pF			50	ns

RS-485 Transceiver with Integrated Low-Dropout Regulator and AutoDirection Control

SWITCHING CHARACTERISTICS—MAX13415E (continued)

($V_{CC} = +6.0V$ to $+28V$, $T_A = T_{MIN}$ to T_{MAX} , unless otherwise noted. Typical values are at $V_{CC} = +7.5V$, $C_S = 1\mu F$, and $T_A = +25^\circ C$.) (Note 2)

PARAMETER	SYMBOL	CONDITIONS	MIN	TYP	MAX	UNITS
Driver Disable from Output Low	t_{DLZ}	S1 closed, Figure 4, $R_L = 500\Omega$, $C_L = 15pF$			50	ns
RECEIVER						
Receiver Propagation Delay	t_{RPLH}	$C_L = 15pF$ (at RO), Figures 5 and 6			75	ns
	t_{RPHL}				75	
Receiver Output Skew	t_{RSKEW}	$C_L = 15pF$ (at RO), Figures 5 and 6			8	ns
Maximum Data Rate	f_{MAX}		16			Mbps
Receiver Enable to Output High	t_{RZH}	S2 closed, Figure 7, $C_L = 15pF$			50	ns
Receiver Enable to Output Low	t_{RZL}	S1 closed, Figure 7, $C_L = 15pF$			50	ns
Receiver Disable Time from Low	t_{RLZ}	S1 closed, Figure 7, $C_L = 15pF$			50	ns
Receiver Disable Time from High	t_{RZH}	S2 closed, Figure 7, $C_L = 15pF$			50	ns

Note 2: C_S is the compensation capacitor on V_{REG} for the MAX13412E–MAX13415E versions. C_S must have an ESR value of 20m Ω or less.

Note 3: Parameters are guaranteed for $+6.0V \leq V_{CC} \leq +28V$.

Typical Operating Characteristics

($V_{CC} = +7.5V$, $T_A = +25^\circ C$, unless otherwise noted.)

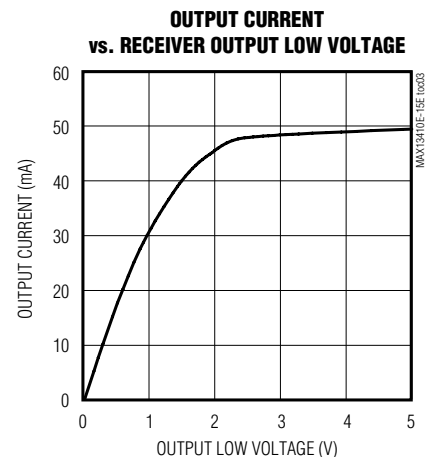
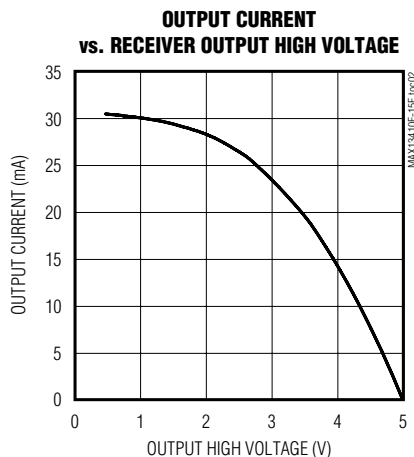
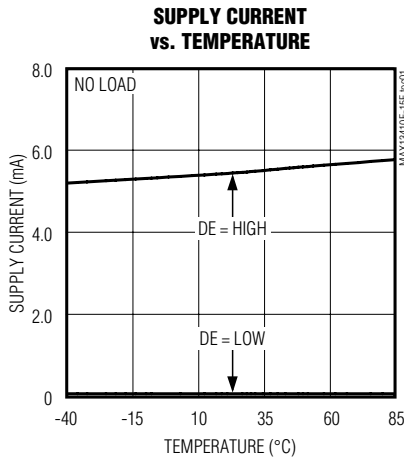

RS-485 Transceiver with Integrated Low-Dropout Regulator and AutoDirection Control

Typical Operating Characteristics (continued)

($V_{CC} = +7.5V$, $T_A = +25^\circ C$, unless otherwise noted.)

MAX13410E-MAX13415E

RECEIVER OUTPUT HIGH VOLTAGE vs. TEMPERATURE

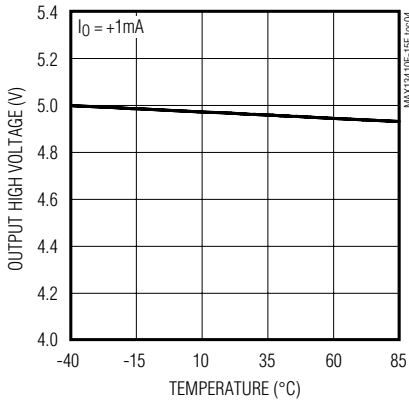

RECEIVER OUTPUT LOW VOLTAGE vs. TEMPERATURE

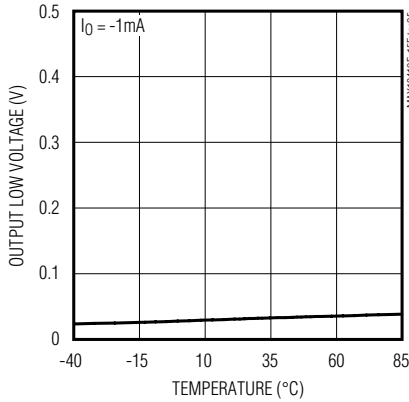

DIFFERENTIAL OUTPUT CURRENT vs. DIFFERENTIAL OUTPUT VOLTAGE

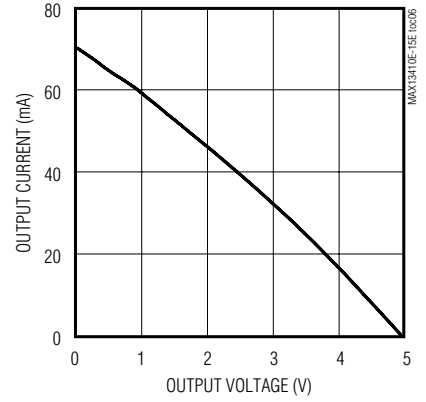

DRIVER DIFFERENTIAL OUTPUT VOLTAGE vs. TEMPERATURE

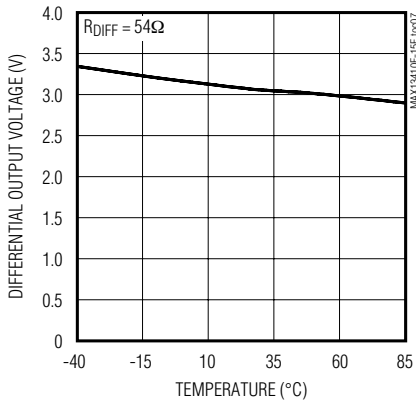

OUTPUT CURRENT vs. TRANSMITTER OUTPUT HIGH VOLTAGE

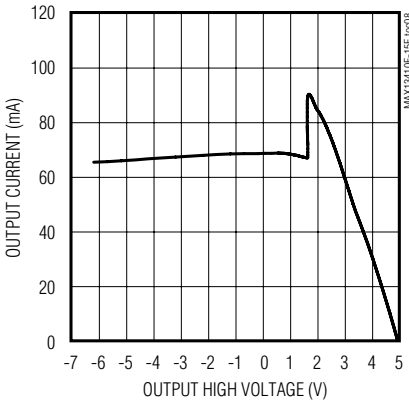

OUTPUT CURRENT vs. TRANSMITTER OUTPUT LOW VOLTAGE

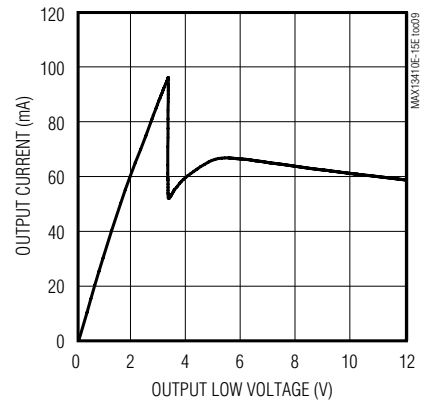

SHUTDOWN CURRENT vs. TEMPERATURE

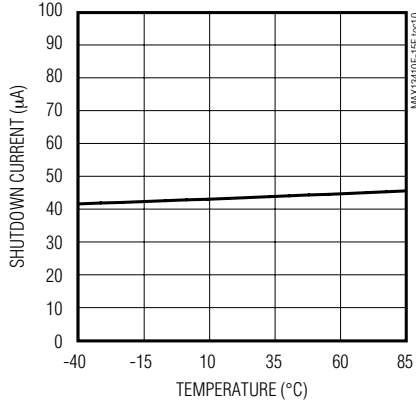

DRIVER PROPAGATION vs. TEMPERATURE (MAX13412E)

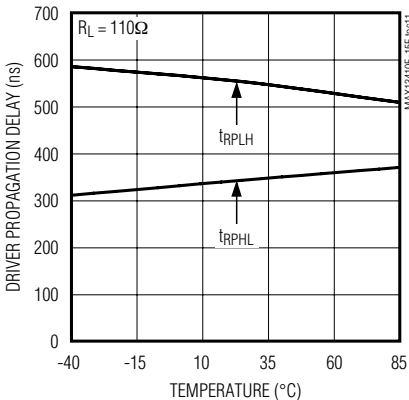

DRIVER PROPAGATION vs. TEMPERATURE (MAX13413E)

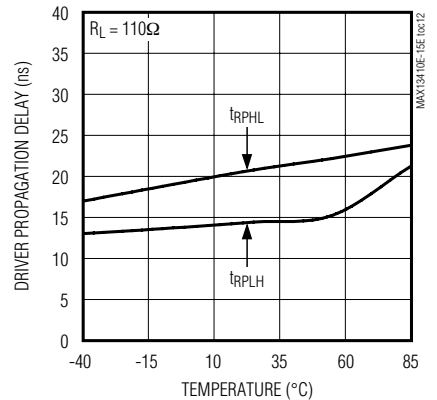

RS-485 Transceiver with Integrated Low-Dropout Regulator and AutoDirection Control

Typical Operating Characteristics (continued)

($V_{CC} = +7.5V$, $T_A = +25^\circ C$, unless otherwise noted.)

RECEIVER PROPAGATION vs. TEMPERATURE (MAX13410E/MAX13412E)

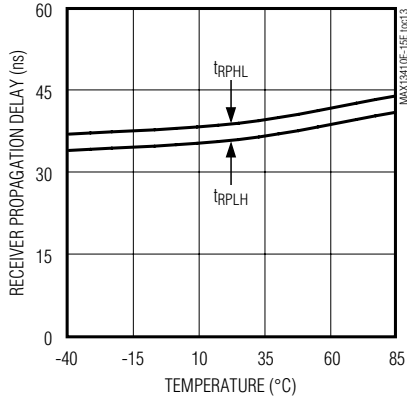

RECEIVER PROPAGATION vs. TEMPERATURE (MAX13411E/MAX13413E)

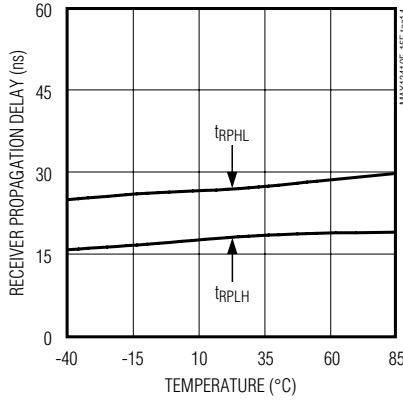

DRIVER PROPAGATION (250kbps) (MAX13412E)

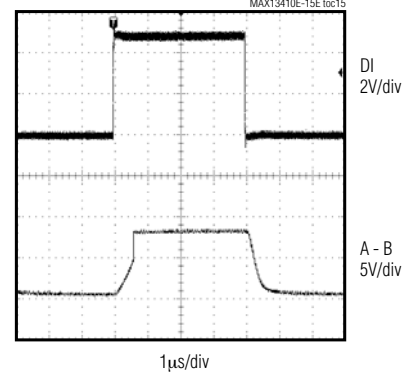

DRIVER PROPAGATION (16kbps) (MAX13413E)

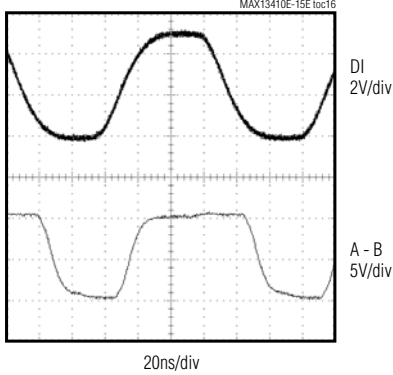

RECEIVER PROPAGATION (16kbps) (MAX13413E)

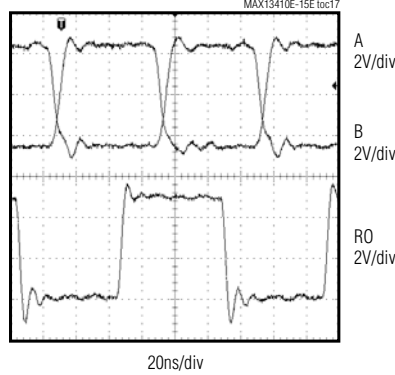

DRIVING A LARGE CAPACITIVE LOAD 16nF (19.2kbps) (MAX13412E)

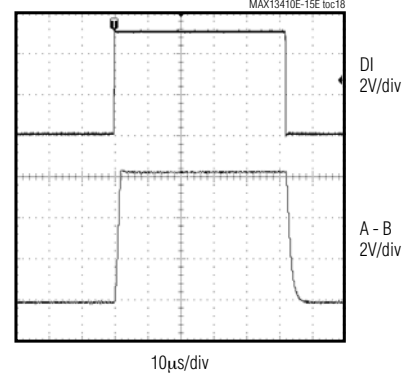

DRIVING A LARGE CAPACITIVE LOAD 16nF (1Mbps) (MAX13413E)

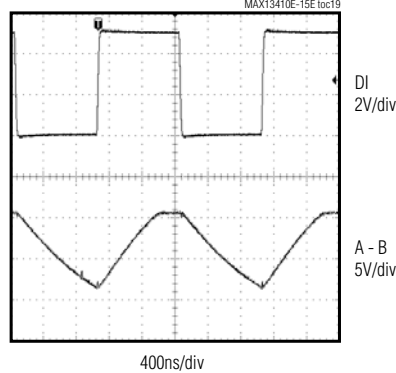

DRIVING A LARGE CAPACITIVE LOAD 16nF (50kbps) (MAX13413E)

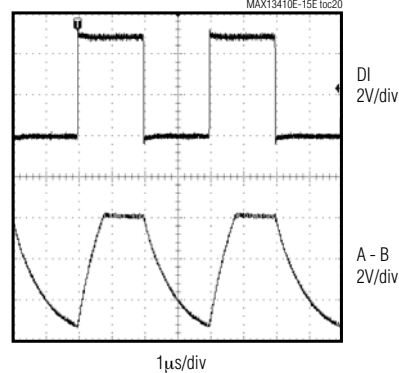

RS-485 Transceiver with Integrated Low-Dropout Regulator and AutoDirection Control

Test Circuits and Waveforms

MAX13410E-MAX13415E

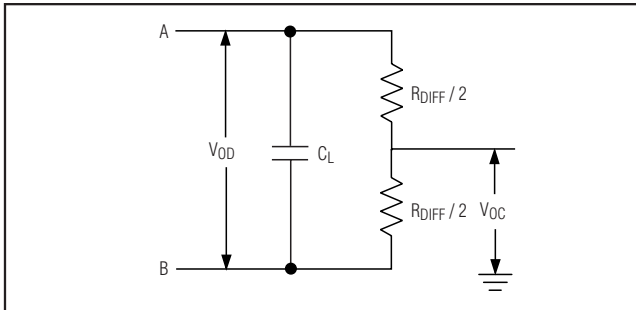

Figure 1. Driver DC Test Load

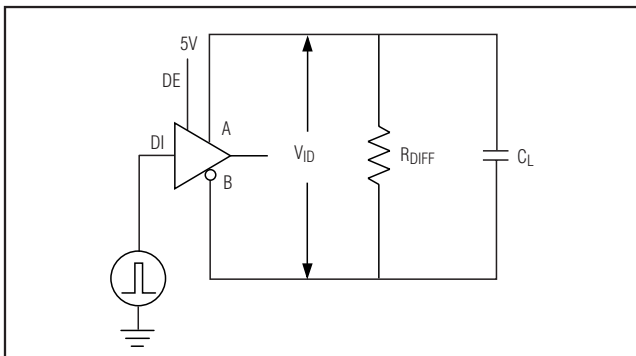

Figure 2a. Driver-Timing Test Circuit

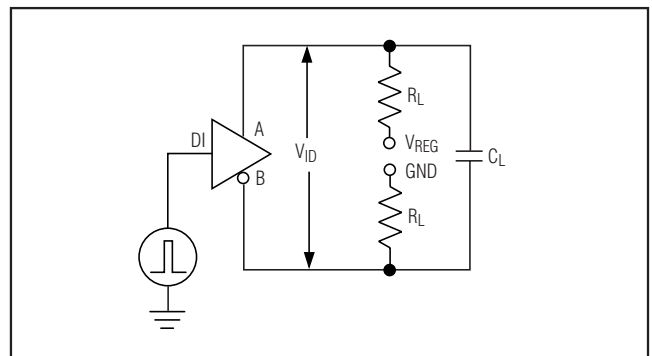

Figure 2b. Driver-Timing Test Circuit

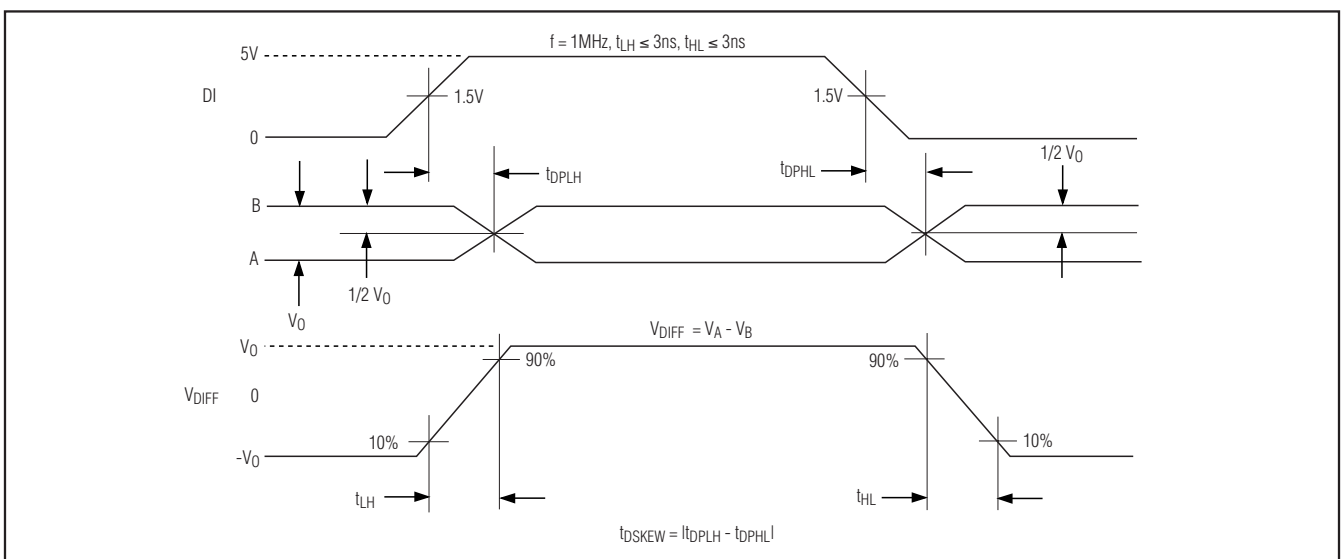

Figure 3a. Driver Propagation Delays

RS-485 Transceiver with Integrated Low-Dropout Regulator and AutoDirection Control

Test Circuits and Waveforms (continued)

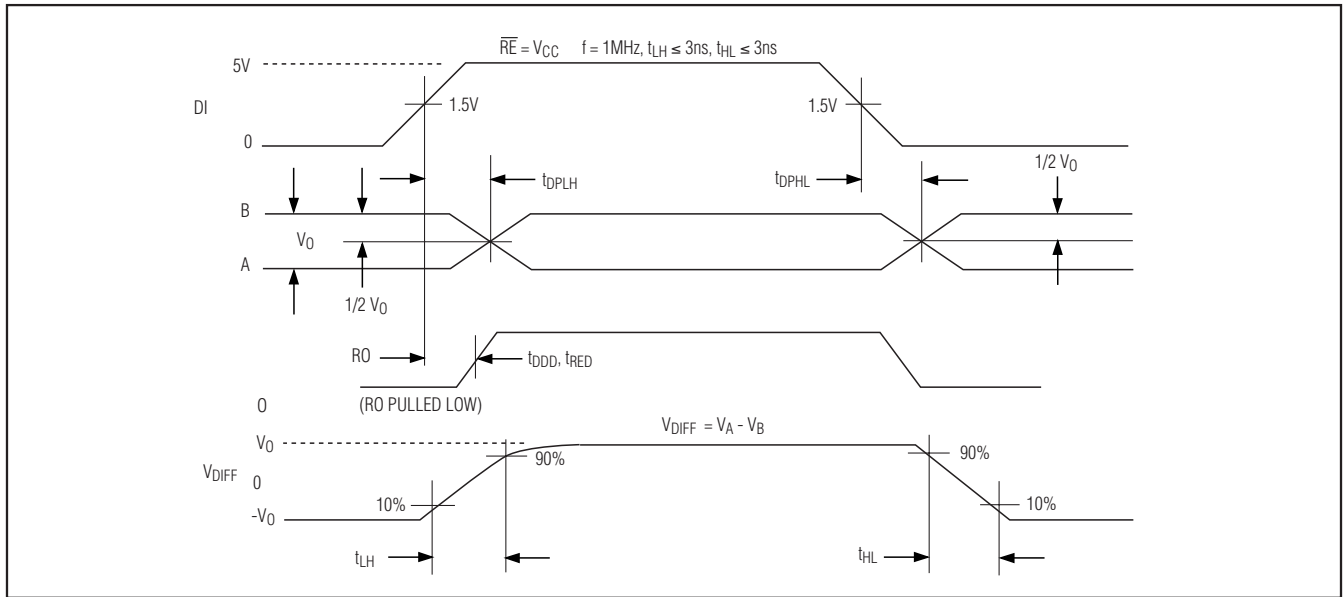

Figure 3b. Driver Propagation Delays

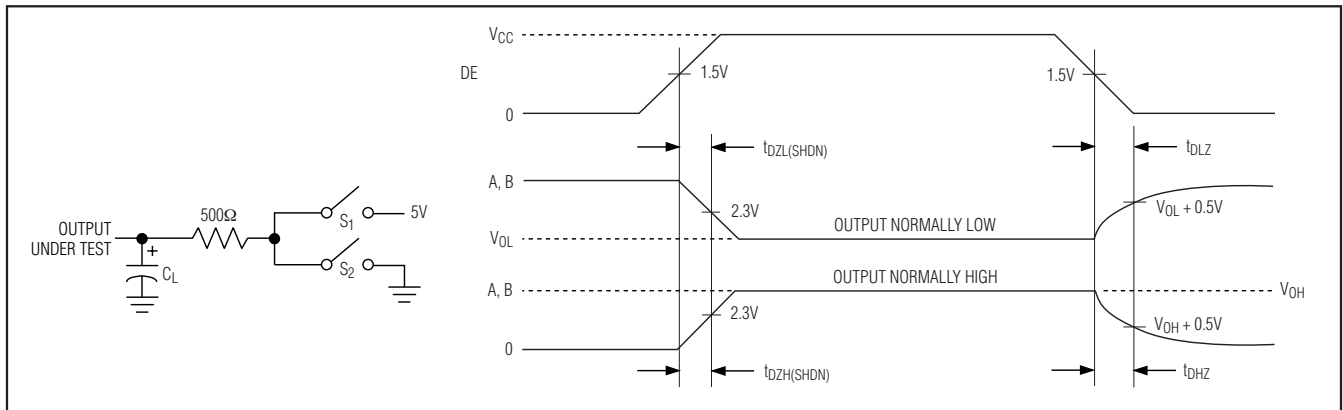

Figure 4. Driver Enable and Disable Times

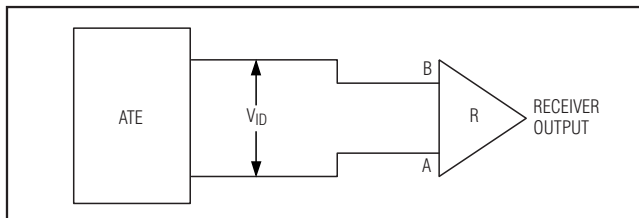

Figure 5. Receiver-Propagation-Delay Test Circuit

RS-485 Transceiver with Integrated Low-Dropout Regulator and AutoDirection Control

Test Circuits and Waveforms (continued)

MAX13410E-MAX13415E

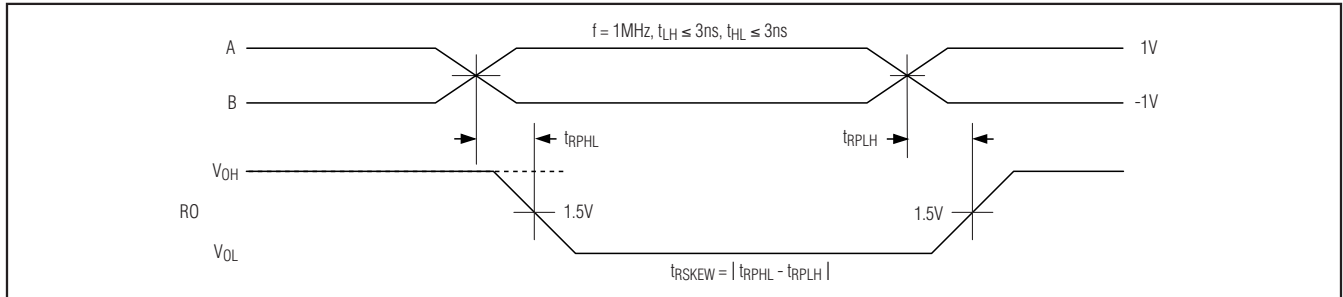

Figure 6. Receiver Propagation Delays

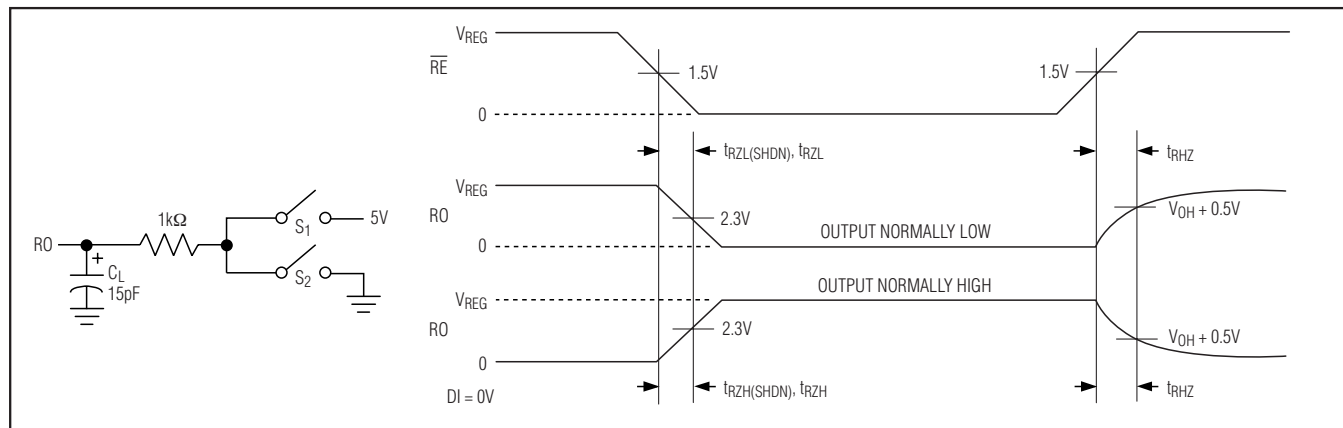

Figure 7. Receiver Enable and Disable Times

RS-485 Transceiver with Integrated Low-Dropout Regulator and AutoDirection Control

Pin Description

PIN			NAME	FUNCTION
MAX13410E/ MAX13411E	MAX13412E/ MAX13413E	MAX13414E/ MAX13415E		
1	—	1	RO	Receiver Output. When receiver is enabled and $V_A - V_B \geq -50\text{mV}$, RO is high. If $V_A - V_B \leq -200\text{mV}$, RO is low. Note: RO is referenced to the LDO output (V_{REG}).
2	—	—	$\overline{\text{RE}}$	Receiver Output Enable. Drive $\overline{\text{RE}}$ low to enable RO. Drive $\overline{\text{RE}}$ high to disable the RO output and put the RO output in a high-impedance state.
3	—	—	DE	Driver Output Enable. Drive DE low to put the driver output in three-state. Drive DE high to enable the driver.
4	4	4	DI	Driver Input. Drive DI low to force the noninverting output low and the inverting output high. Drive DI high to force the noninverting output high and inverting output low. DI is an input to the internal state machine that automatically enables and disables the driver (for the MAX13412E/MAX13413E). See the <i>Function Tables</i> and <i>General Description</i> for more information.
5	5	5	GND	Ground
6	6	6	A	Noninverting Receiver Input and Noninverting Driver Output
7	7	7	B	Inverting Receiver Input and Inverting Driver Output
8	8	8	V_{CC}	Positive Supply. Bypass V_{CC} with a 0.1 μF ceramic capacitor to GND.
—	1	—	RO	Receiver Output. When receiver is enabled and $V_A - V_B \geq -100\text{mV}$, RO is high. If $V_A - V_B \leq -100\text{mV}$, RO is low. Note: RO is referenced to the LDO output (V_{REG}).
—	2	—	$\overline{\text{RE}}$	Receiver Output Enable. Drive $\overline{\text{RE}}$ low to force the RO output to be enabled. Drive $\overline{\text{RE}}$ high to let the AutoDirection circuit control RO.
—	3	3	V_{REG}	LDO Output. V_{REG} is fixed at +5V. Bypass V_{REG} with a low ESR (20m Ω or less) and a 1 μF (min) ceramic capacitor.
—	—	2	DE/ $\overline{\text{RE}}$	Receiver and Driver Output Enable. Drive DE/ $\overline{\text{RE}}$ low to enable RO and disable the driver. Drive DE/ $\overline{\text{RE}}$ high to disable RO and enable the driver.
EP	EP	EP	EP	Exposed Pad. EP is internally connected to GND. For enhanced thermal dissipation, connect EP to a copper area as large as possible. Do not use EP as a sole ground connection.

RS-485 Transceiver with Integrated Low-Dropout Regulator and AutoDirection Control

MAX13410E-MAX13415E

Function Tables for the MAX13410E/MAX13411E

TRANSMITTING				
INPUT			OUTPUT	
RE	DE	DI	B	A
X	1	1	0	1
X	1	0	1	0
0	0	X	High impedance	High impedance
1	0	X	High impedance (shutdown)	

RECEIVING			
INPUT			OUTPUT
RE	DE	A - B	RO
0	X	$\geq -50\text{mV}$	1
0	X	$\leq -200\text{mV}$	0
0	X	Open/Short	1
1	1	X	High impedance
1	0	X	High impedance (shutdown)

X = Don't care, shutdown mode, driver, and receiver outputs are in high impedance.

Function Tables for the MAX13412E/MAX13413E

TRANSMITTING				
INPUTS			OUTPUTS	
DI	A - B > V _{DT}	ACTION	A	B
0	X	Turn driver ON	0	1
1	False	If driver was OFF, keep it OFF	High impedance	High impedance
1	False	If driver was ON, keep it ON	1	0
1	True	Turn driver OFF	High impedance	High impedance

RECEIVING				
INPUTS				OUTPUT
RE	A - B	DRIVER STATE	RECEIVER STATE	RO
0	$\geq -100\text{mV}$	X	ON	1
0	$\leq -100\text{mV}$	X	ON	0
1	X	ON	OFF	High impedance
1	$\geq -100\text{mV}$	OFF	ON	1
1	$\leq -100\text{mV}$	OFF	ON	0

X = Don't care, shutdown mode, driver, and receiver outputs are in high impedance.

Function Tables for the MAX13414E/MAX13415E

TRANSMITTING			
INPUT		OUTPUT	
DE/RE	DI	B	A
0	X	High impedance	High impedance
1	1	0	1
1	0	1	0

RECEIVING		
INPUT		OUTPUT
DE/RE	A - B	RO
0	$\geq -50\text{mV}$	1
0	$\leq -200\text{mV}$	0
0	Open/Short	1
1	X	High impedance

X = Don't care, shutdown mode, driver, and receiver outputs are in high impedance.

RS-485 Transceiver with Integrated Low-Dropout Regulator and AutoDirection Control

Detailed Description

The MAX13410E–MAX13415E are half-duplex RS-485/RS-422-compatible transceivers optimized for isolated applications. These devices feature an internal LDO regulator, one driver, and one receiver. The internal LDO allows the part to operate from an unregulated +6V to +28V power supply. The AutoDirection feature reduces the number of optical isolators needed in isolated applications. Other features include $\pm 15\text{kV}$ ESD protection (MAX13412E/MAX13413E only), $\pm 14\text{kV}$ (MAX13410E/MAX13411E only) fail-safe circuitry, slew-rate limiting, and full-speed operation.

The MAX13410E–MAX13415E internal LDO generates a $5\text{V} \pm 10\%$ power supply that is used to power its internal circuitry. The MAX13412E–MAX13415E bring the 5V to an output VREG that allows the user to power additional external circuitry with up to 20mA to further reduce external components. The MAX13410E/MAX13411E do not have a 5V output and come in industry-compatible pinouts. This allows easy replacement in existing designs.

The MAX13412E/MAX13413E feature Maxim's proprietary AutoDirection control. This architecture eliminates the need for the DE and $\overline{\text{RE}}$ control signals. In isolated applications, this reduces the cost and size of the system by reducing the number of optical isolators required.

The MAX13410E/MAX13412E/MAX13414E feature reduced slew-rate drivers that minimize EMI and reduce reflections caused by improperly terminated cables, allowing error-free transmission up to 500kbps. The MAX13411E/MAX13413E/MAX13415E are not slew-rate limited, allowing transmit speeds up to 16Mbps.

The MAX13410E–MAX13415E feature a 1/8-unit load receiver input impedance, allowing up to 256 transceivers on the bus. All driver outputs are protected to $\pm 15\text{kV}$ ESD using the Human Body Model. These devices also include fail-safe circuitry, MAX13410E/MAX13411E/MAX13414E/MAX13415E, guaranteeing a logic-high receiver output when the receiver inputs are open or shorted. The receiver outputs a logic-high when the transmitter on the terminated bus is disabled (high impedance).

Internal Low-Dropout Regulator

The MAX13410E–MAX13415E include an internal low-dropout regulator that allows it to operate from input voltages of up to +28V. The internal LDO has a set output voltage of $5\text{V} \pm 10\%$ that is used to power the internal circuitry of the device. The MAX13412E–MAX13415E offer the LDO output at the VREG output. This allows additional external circuitry to be powered without the need for additional external regulators. The VREG output can source up to 20mA.

When using these devices with high input voltages and heavily loaded networks, special care must be taken that the power dissipation rating of the package and the maximum die temperature of the device is not exceeded. Die temperature of the part can be calculated using the equation:

$$T_{\text{DIE}} = [(\theta_{\text{JC}} + \theta_{\text{CA}}) \times P_{\text{DISS}}] + T_{\text{AMBIENT}}, \text{ where}$$

T_{DIE} = Temperature of the Die

$\theta_{\text{JC}} = 6.0^\circ\text{C/W}$ = Junction-to-Case Thermal Resistance

θ_{CA} = Case-to-Ambient Thermal Resistance

$\theta_{\text{JA}} = \theta_{\text{JC}} + \theta_{\text{CA}} = 52.0^\circ\text{C/W}$ = Junction-to-Ambient Thermal Resistance

$P_{\text{DISS}} = (I_{\text{CC}} - V_{\text{CC}}) + [(V_{\text{CC}} - V_{\text{REG}}) \times I_{\text{REG}}] + [(V_{\text{CC}} - V_{\text{OD}}) \times I_{\text{DRIVER}}]$ = Power Dissipation of the Part

T_{AMBIENT} = Ambient Temperature

V_{CC} = Voltage on the VCC Input

I_{CC} = Current in to VCC

V_{REG} = Voltage on the VREG Output

I_{REG} = Current Drawn from the VREG Output

V_{OD} = Voltage at the Driver Output ($I_{\text{VA}} - V_{\text{BI}}$)

I_{DRIVER} = Current Driven Out of the Driver. Typically, this is the current through the termination resistor.

The absolute maximum rating of the die temperature of the MAX13410E–MAX13415E is $+150^\circ\text{C}$. To protect the part from overheating, there is an internal thermal shutdown that shuts down the part when the die temperature reaches $+150^\circ\text{C}$. To prevent damage to the part, and to prevent the part from entering thermal shutdown, keep the die temperature below 150°C , plus some margin. The circuit designer can minimize the die temperature by controlling the following parameters:

- V_{CC}
- I_{REG}
- θ_{CA}

Measuring the VCC Current

Measured current at the VCC pin is a function of the quiescent current of the part, the amount of current that the drivers must supply to the load, and in the case of the MAX13412E–MAX13415E, the load on the VREG output. In most cases, the load that the drivers must supply will be the termination resistor(s). Ideally, the termination resistance should match the characteristic impedance of the cable and is usually not a parameter the circuit designer can easily change. In some low-speed, short-cable applications, proper termination

RS-485 Transceiver with Integrated Low-Dropout Regulator and AutoDirection Control

Functional Diagrams

Functional Diagram for the MAX13410E/MAX13411E/MAX13414E/MAX13415E

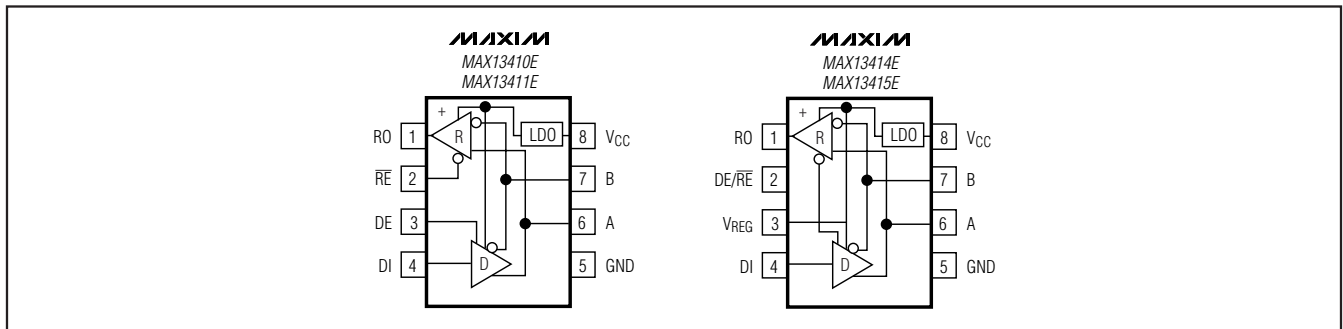

Functional Diagram for the MAX13412E/MAX13413E

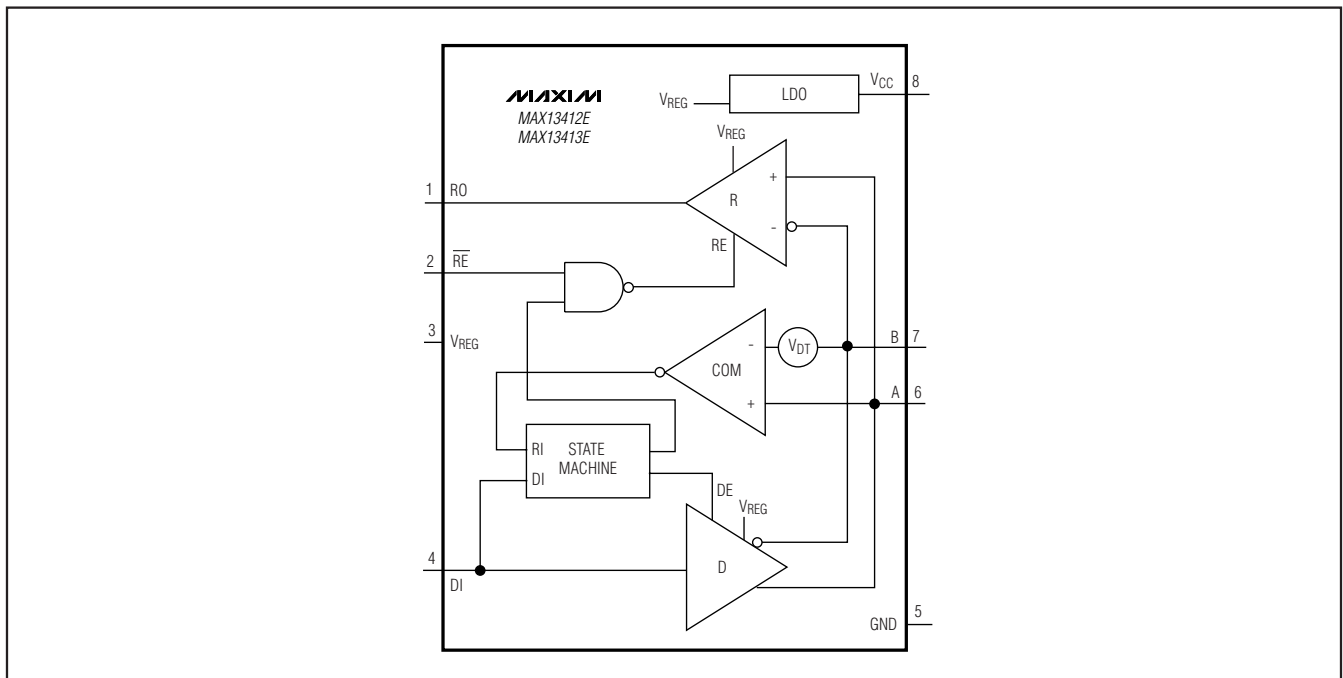

may not be necessary. In these cases, the drive current can be reduced to minimize the die temperature.

Minimizing the load on the VREG output lowers the power dissipation of the part and ultimately reduces the maximum die temperature.

θ_{CA}

θ_{CA} is the thermal resistance from case to ambient and is independent of the MAX13410E–MAX13415E. θ_{CA} is primarily a characteristic of the circuit-board design. The

largest contributing factor of θ_{CA} will be the size and weight of the copper connected to the exposed paddle of the MAX13410E–MAX13415E. Lower the thermal resistance by using as large a pad as possible. Additionally, vias can be used to connect the pad to other ground planes in the circuit board.

Note that θ_{JC} is the thermal resistance of the part from junction-to-case temperature and is fixed at 6.0°C/W. It is solely based on the die and package characteristics of

MAX13410E-MAX13415E

RS-485 Transceiver with Integrated Low-Dropout Regulator and AutoDirection Control

the MAX13410E–MAX13415E. The circuit-board designer has no control over this parameter.

Fail Safe

The MAX13410E/MAX13411E/MAX13414E/MAX13415E guarantee a logic-high receiver output when the receiver inputs are shorted or open, or when they are connected to a terminated transmission line with all drivers disabled. This is done by setting the receiver input threshold between -50mV and -200mV . If the differential receiver input voltage ($A - B$) is greater than or equal to -50mV , RO is logic-high. If ($A - B$) is less than or equal to -200mV , RO is logic-low. In the case of a terminated bus with all transmitters disabled, the receiver's differential input voltage is pulled to 0 by the termination. With the receiver thresholds of the MAX13410E/MAX13411E/MAX13414E/MAX13415E, the result is a logic-high with a 50mV minimum noise margin. Unlike previous fail-safe devices, the -50mV to -200mV threshold complies with the $\pm 200\text{mV}$ EIA/TIA-485 standard.

AutoDirection Circuitry

The AutoDirection circuitry in the MAX13412E/MAX13413E is a technique to minimize the number of signals needed to drive the part. This is especially useful in very low cost, isolated systems. In a typical isolated system, an optocoupler is used for each control signal to cross the isolation barrier. These optocouplers add cost, size and consume power. Without the AutoDirection circuitry, three to four optocouplers may be required for each transceiver. With the AutoDirection circuitry, the number of optocouplers can be reduced to two.

Typical RS-485 transceivers have four signals on the control side of the part. These are RO (receiver output), $\overline{\text{RE}}$ (receiver enable), DE (driver enable), and DI (driver input). In some cases, DE and $\overline{\text{RE}}$ may be connected together to reduce the number of control signals to three. In half-duplex systems, the $\overline{\text{RE}}$ and DE signals determine if the part is transmitting or receiving. When the part is receiving, the transmitter is in a high-impedance state. In a fully compliant RS-485 system, all three or four signals are required. However, with careful design and Maxim's AutoDirection feature, the number of control signals can be reduced to just RO and DI in an RS-485 compatible system. This feature assumes the DI input idles in the high state while the receiver portion of the MAX13412E/MAX13413E is active. It also requires an external pullup resistor on A and pulldown resistor on B (see the typical application circuit, Figure 10). The following is a description of how AutoDirection works.

When DI is low, the MAX13412E/MAX13413E always drive the bus low. When DI transitions from a low to a

high, the drivers actively drive the output until $(A - B) > V_{DT}$. Once $(A - B)$ is greater than V_{DT} , the drivers are disabled, letting the pullup/pulldown resistors hold the A and B lines in the correct state. This allows other transmitters on the bus to pull the bus low.

Pullup and Pulldown Resistors

The pullup and pulldown resistors on the A and B lines are required for proper operation of the MAX13412E and MAX13413E, although their exact value is not critical. They function to hold the bus in the high state ($A - B > 200\text{mV}$) when all the transmitters are in a high-impedance state due to either a shutdown condition or AutoDirection. Determining the best value to use for these resistors depends on many factors, such as termination resistor values, noise, number of transceivers on the bus, etc. Size these resistors so that, under all conditions, $(A - B) > 200\text{mV}$ for ALL receivers on the bus.

Idle State

When not transmitting data, the MAX13412E/MAX13413E require the DI input to be driven high to remain in the idle state. A conventional RS-485 transceiver has DE and $\overline{\text{RE}}$ inputs that are used to enable and disable the driver and receiver. However, the MAX13412E/MAX13413E do not have a DE input, and instead use an internal state machine to enable and disable the drivers. DI must be driven high to go to the idle state.

Enhanced ESD Protection

As with all Maxim devices, ESD-protection structures are incorporated on all pins to protect against electrostatic discharges encountered during handling and assembly. The driver outputs and receiver inputs of the MAX13410E–MAX13415E have extra protection against static electricity. Maxim's engineers have developed state-of-the-art structures to protect these pins against ESD of $\pm 15\text{kV}$ (MAX13412E/MAX13413E) and $\pm 14\text{kV}$ (MAX13410E/MAX13411E) without damage. The ESD structures withstand high ESD in all states: normal operation, shutdown, and powered down. After an ESD event, the MAX13410E–MAX13415E keep working without latching or damage.

ESD protection can be tested in various ways. The transmitter outputs and receiver inputs of the MAX13410E–MAX13415E are characterized for protection to the following limits:

- $\pm 15\text{kV}$ using the Human Body Model (MAX13412E/MAX13413E)

- $\pm 14\text{kV}$ using the Human Body Model (MAX13410E/MAX13411E)

RS-485 Transceiver with Integrated Low-Dropout Regulator and AutoDirection Control

MAX13410E-MAX13415E

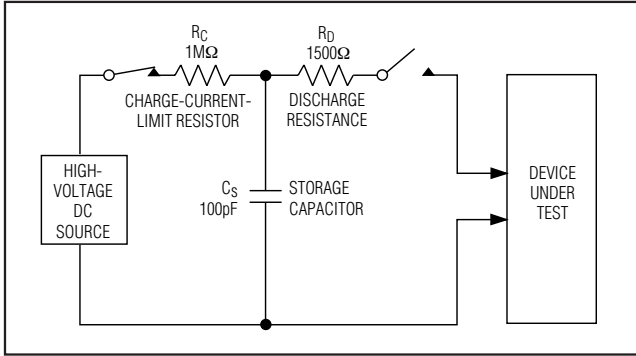

Figure 8a. Human Body ESD Test Model

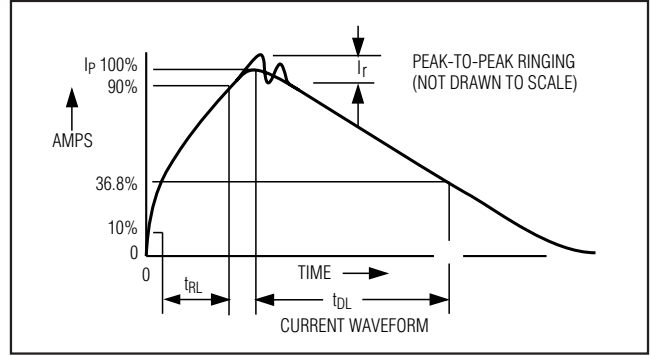

Figure 8b. Human Body Current Waveform

ESD Test Conditions

ESD performance depends on a variety of conditions. Contact Maxim for a reliability report that documents test setup, test methodology, and test results.

Human Body Model

Figure 8a shows the Human Body Model, and Figure 8b shows the current waveform it generates when discharged into a low impedance. This model consists of a 100pF capacitor charged to the ESD voltage of interest, which is then discharged into the test device through a 1.5kΩ resistor.

Applications Information

Typical Applications

The MAX13410E–MAX13415E transceivers are designed for half-duplex, bidirectional data communications on multipoint bus transmission lines. To minimize reflections, terminate the line at both ends in its characteristic impedance, and keep stub lengths off the main line as short as possible. The slow-rate-limited MAX13410E/MAX13412E/MAX13414E are more tolerant of imperfect termination.

Typical Application Circuit for the MAX13410E and MAX13411E

This application circuit shows the MAX13410E/MAX13411E being used in an isolated application (see Figure 9). The MAX13410E/MAX13411E use the industry-standard pin out but do not have a VREG output for biasing external circuitry. The positive temperature coefficient (PTC) and transient voltage suppressor (TVS) clamp circuit on the RS-485 outputs are intended to provide overvoltage fault protection and are optional based on the requirements of the design.

Typical Application Circuit for the MAX13412E and MAX13413E

This application circuit shows the MAX13412E and MAX13413E being used in an isolated application where the AutoDirection feature is implemented to reduce the number of optical isolators to two (see Figure 10). The MAX13412E/MAX13413E provide a VREG output that can be used to power external circuitry up to 20mA.

Typical Application Circuit for the MAX13414E and MAX13415E

This application circuit shows the MAX13414E/MAX13415E being used in an isolated application using an unregulated power supply with three optical isolators (see Figure 11). The MAX13414E/MAX13415E provide a VREG output that can be used to power external circuitry up to 20mA.

256 Transceivers on the Bus

The RS-485 standard specifies the load each receiver places on the bus in terms of unit loads. An RS-485-compliant transmitter can drive 32 one-unit load receivers when used with a 120Ω cable that is terminated on both ends over a -7V to +12V common-mode range. The MAX13410E–MAX13415E are specified as 1/8 unit loads. This means a compliant transmitter can drive up to 256 devices of the MAX13410E–MAX13415E. Reducing the common mode, and/or changing the characteristic impedance of the cable, changes the maximum number of receivers that can be used. Refer to the TIA/EIA-485 specification for further details.

Proper Termination and Cabling/Wiring Configurations

When the data rates for RS-485 are high relative to the cable length it is driving, the system is subject to proper

RS-485 Transceiver with Integrated Low-Dropout Regulator and AutoDirection Control

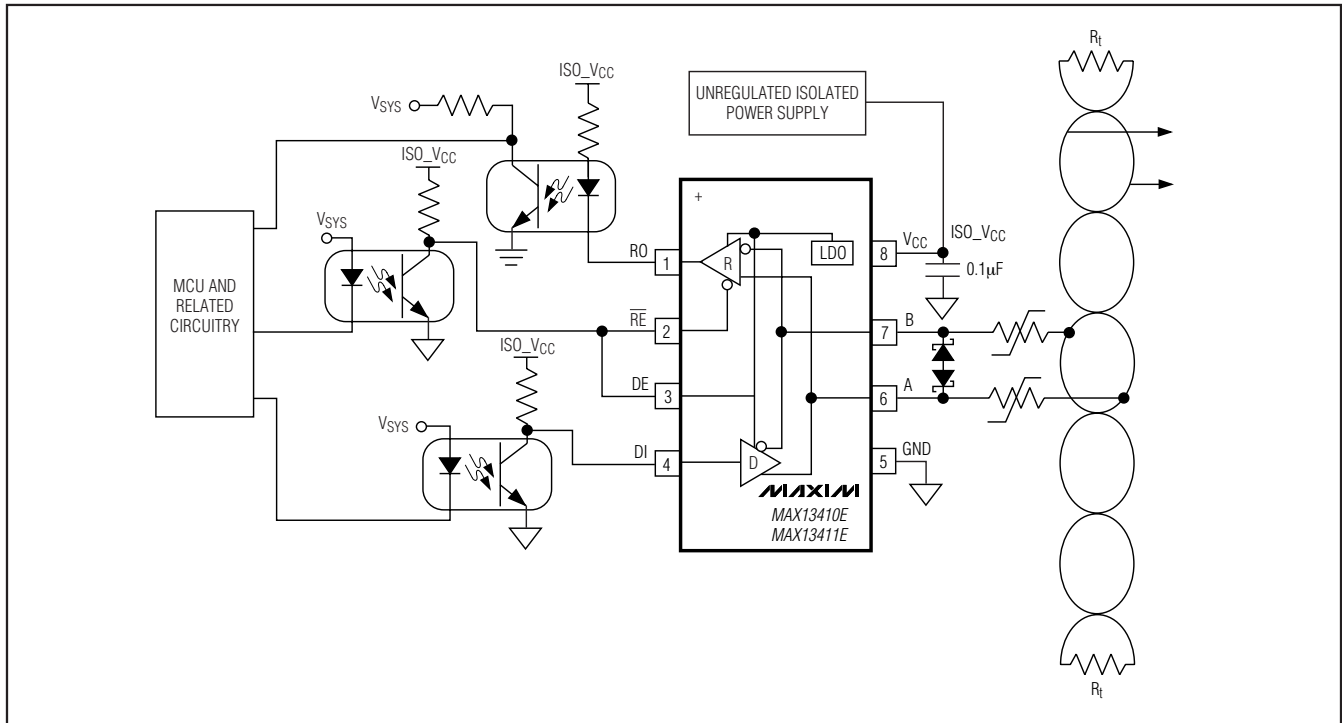

Figure 9. Typical Application Circuit for the MAX13410E/MAX13411E

transmission line design. In most cases, a single, controlled-impedance cable or trace should be used and should be properly terminated on both ends with the characteristic impedance of the cable/trace. RS-485 transceivers should be connected to the cable/ traces with minimum-length wires to prevent stubs. Star configurations and improperly terminated cables can cause data loss. Refer to the *Application Notes* section of the Maxim website or to TIA/EIA publication TSB-89-A for further information. While proper termination is always desirable, in some cases, such as when data rates are very low, it may be desirable and advantageous to not properly terminate the cables. In such cases, it is up to the designer to ensure that the improper termination and resultant reflections (etc.) will not corrupt the data.

Reduced EMI and Reflections

The MAX13410E/MAX13412E/MAX13414E feature reduced slew-rate drivers that minimize EMI and reduce reflections caused by improperly terminated cables, allowing error-free data transmission up to 500kbps.

Low-Power Shutdown Mode

Low-power shutdown mode is initiated in the MAX13410E/MAX13411E by driving DE low and driving

\overline{RE} high. In shutdown, the devices draw 65µA (typ) of supply current.

The devices are guaranteed not to enter shutdown if DE is low (while \overline{RE} is high) for less than 50ns. If the inputs are in this state for at least 700ns, the devices are guaranteed to enter shutdown.

Enable times t_{ZH} and t_{ZL} (see the *Switching Characteristics* table) assume the devices were not in a low-power shutdown state. Enable times $t_{ZH}(SHDN)$ and $t_{ZL}(SHDN)$ assume the devices were in shutdown state. It takes drivers and receivers longer to become enabled from low-power shutdown mode ($t_{ZH}(SHDN)$, $t_{ZL}(SHDN)$) than from driver/receiver disable mode (t_{ZH} , t_{ZL}).

Line Length

The Telecommunications Industry Association (TIA) published the document TSB-89-A: *Application Guidelines for TIA/EIA-485-A*, which is a good reference for determining maximum data rate vs. line length.

Isolated RS-485 Interface

An isolated RS-485 interface electrically isolates different nodes on the bus to protect the bus from problems due to high common-mode voltages that exceed the RS-485 common-mode voltage range, conductive noise, and

RS-485 Transceiver with Integrated Low-Dropout Regulator and AutoDirection Control

MAX13410E-MAX13415E

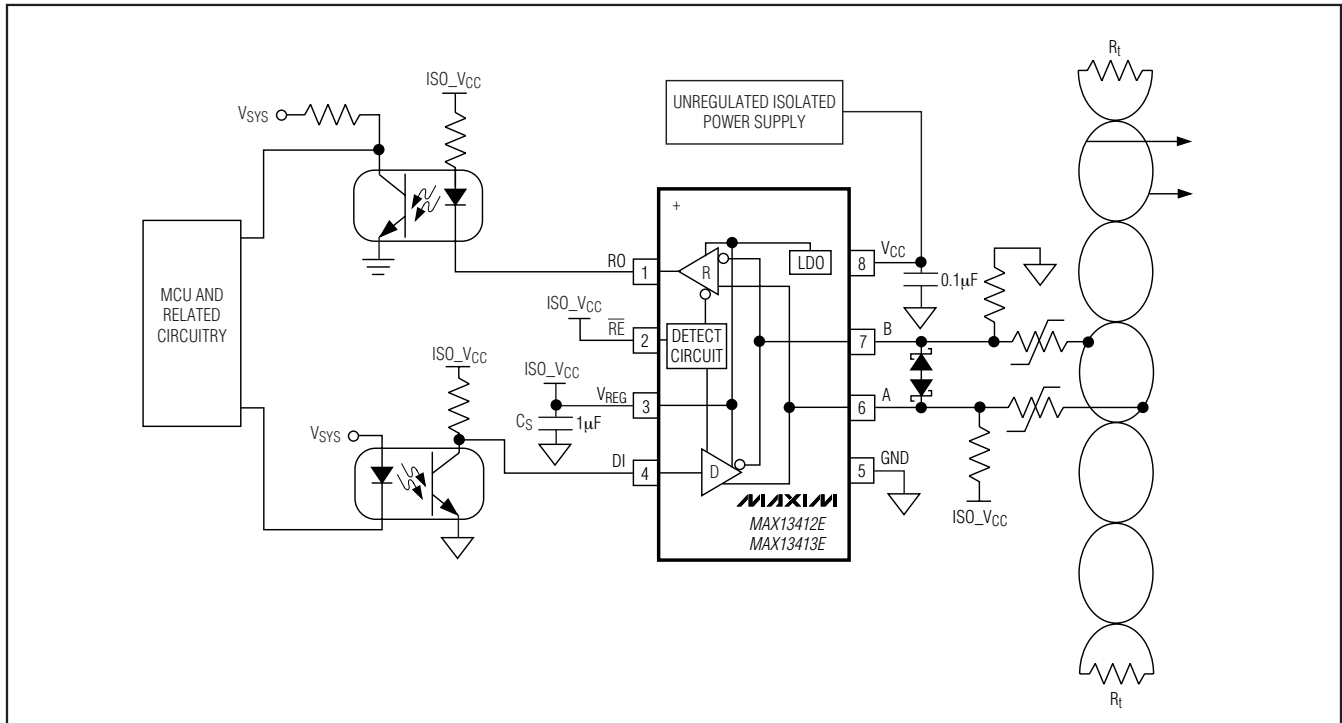

Figure 10. Typical Application Circuit for the MAX13412E/MAX13413E

ground loops. The typical application circuits show an isolated RS-485 interface using the MAX13410E–MAX13415E. The transceiver is powered separately from the controlling circuitry. The AutoDirection feature of the MAX13412E/MAX13413E (see the *AutoDirection Circuitry* section) requires only two optocouplers to electrically isolate the transceiver.

An isolated RS-485 interface electrically isolates different nodes on the bus to protect the bus from problems due to high common-mode voltages that exceed the RS-485 common-mode voltage range. An isolated RS-485 interface has two additional design challenges not normally associated with RS-485 design. These are 1) isolating the control signals and 2) getting isolated power to the transceiver. Optical isolators are the most common way of getting the control signals across the isolation barrier.

Isolated power is typically done using a transformer in either a push-pull or flyback configuration. The MAX845 is an example of an inexpensive, unregulated push-pull converter (see Figure 12). While in theory, the output of an unregulated push-pull converter is predictable, the output voltage can vary significantly due to the non-ideal

characteristics of the transformer, load variations, and temperature drift of the diodes, etc. Variances of $\pm 20\%$ or more would not be uncommon. This would require the addition of a linear regulator to get standard RS-485 transceivers to work. Since the MAX13410E–MAX13415E have the linear regulator built in, this external regulator and its associated cost and size penalties are not necessary. A nominal +7.5V output with a $\pm 20\%$ tolerance would provide a +6V to +9V supply voltage. This is well within the operating range of the MAX13410E–MAX13415E. If the output tolerance is even greater than $\pm 20\%$, adjust the design of the power supply for a higher output voltage to ensure the minimum input voltage requirements are met.

Flyback converters are typically regulated. A TL431 type error amplifier and an optical isolator usually close the loop. The MAX5021 is an example of a small, inexpensive, flyback controller (see Figure 13). While the primary output of the flyback converter is tightly regulated, secondary outputs will not be. As with the unregulated push-pull converter, the MAX13410E–MAX13415E are ideally suited for use with these secondary outputs.

RS-485 Transceiver with Integrated Low-Dropout Regulator and AutoDirection Control

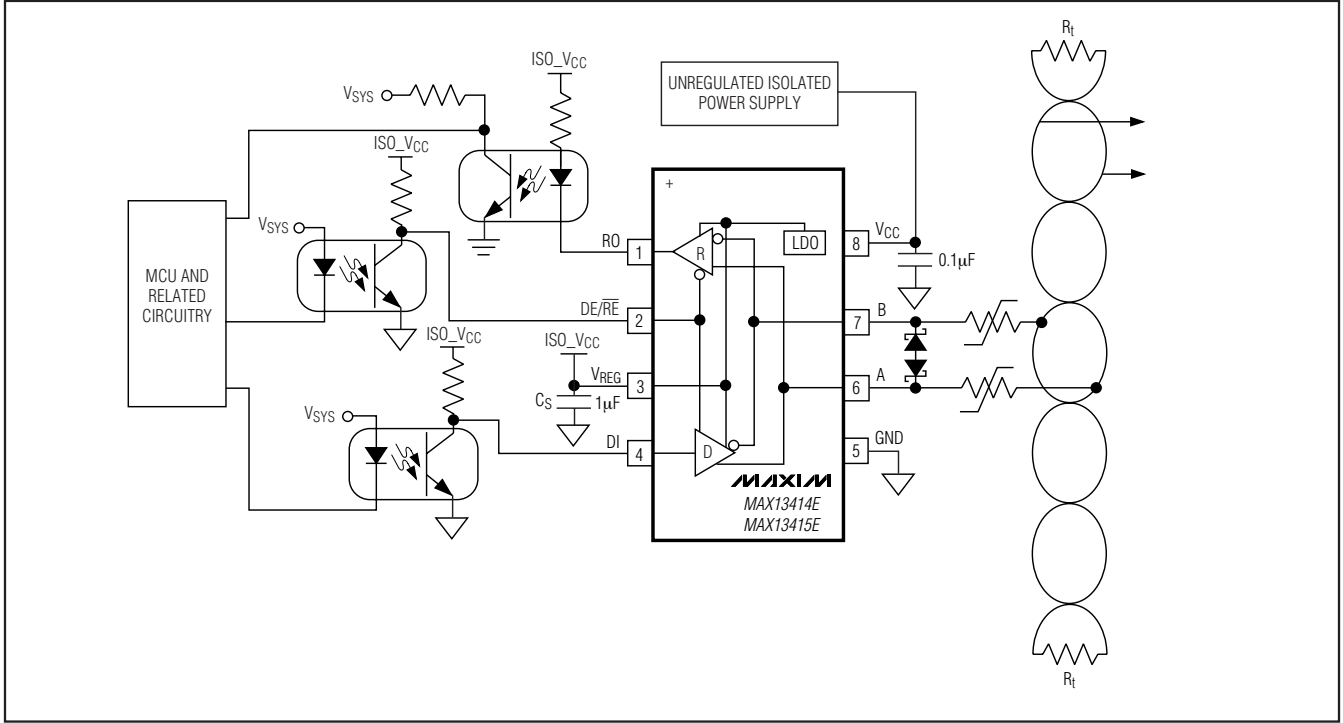

Figure 11. Typical Application Circuit for the MAX13414E/MAX13415E

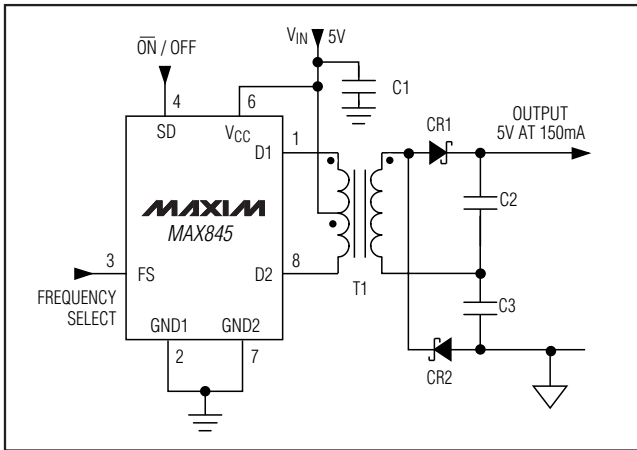

Figure 12. Using the MAX845 to Obtain an Isolated Power Supply

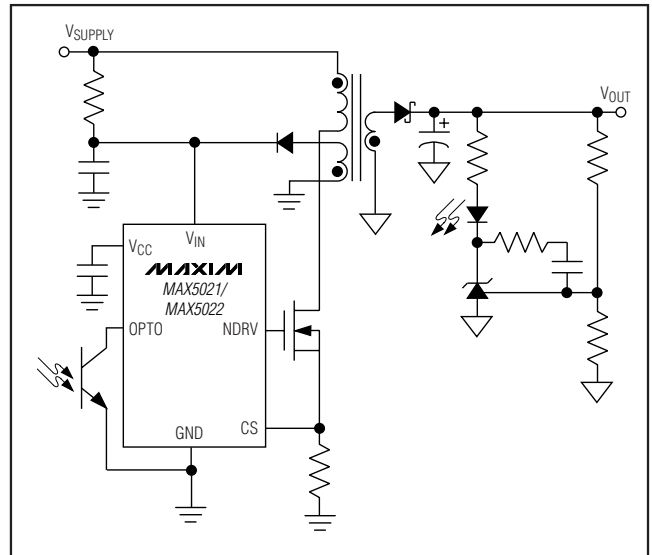
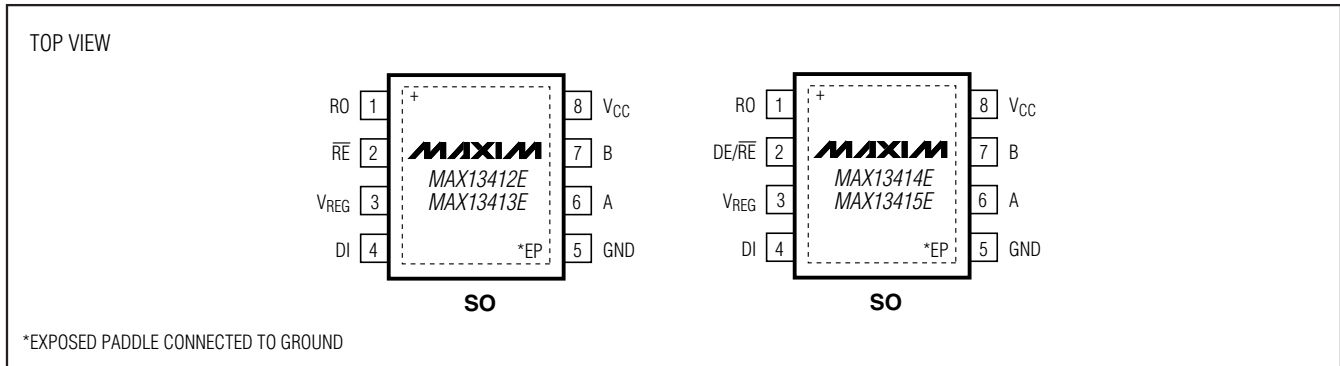

Figure 13. The MAX5021 and MAX5022 provide an isolated power supply with tighter regulation due to feedback using an opto-isolator.

RS-485 Transceiver with Integrated Low-Dropout Regulator and AutoDirection Control

Pin Configurations (continued)



Ordering Information/Selector Guide (continued)

PART	PIN-PACKAGE	AutoDirection	DATA RATE (max)	SLEW-RATE LIMITED	PKG CODE
MAX13412EESA+	8 SO-EP*	Yes	500kbps	Yes	S8E+14
MAX13413EESA+	8 SO-EP*	Yes	16Mbps	No	S8E+14
MAX13414EESA+**	8 SO-EP*	No	500kbps	Yes	S8E+14
MAX13415EESA+**	8 SO-EP*	No	16Mbps	No	S8E+14

Note: All devices operate over the -40°C to $+85^{\circ}\text{C}$ operating temperature range.
+Denotes a lead-free package.

*EP = Exposed paddle.

**Future product—contact factory for availability.

Chip Information

PROCESS TECHNOLOGY: BiCMOS

MAX13410E-MAX13415E

RS-485 Transceiver with Integrated Low-Dropout Regulator and AutoDirection Control

Package Information

(The package drawing(s) in this data sheet may not reflect the most current specifications. For the latest package outline information, go to www.maxim-ic.com/packages.)

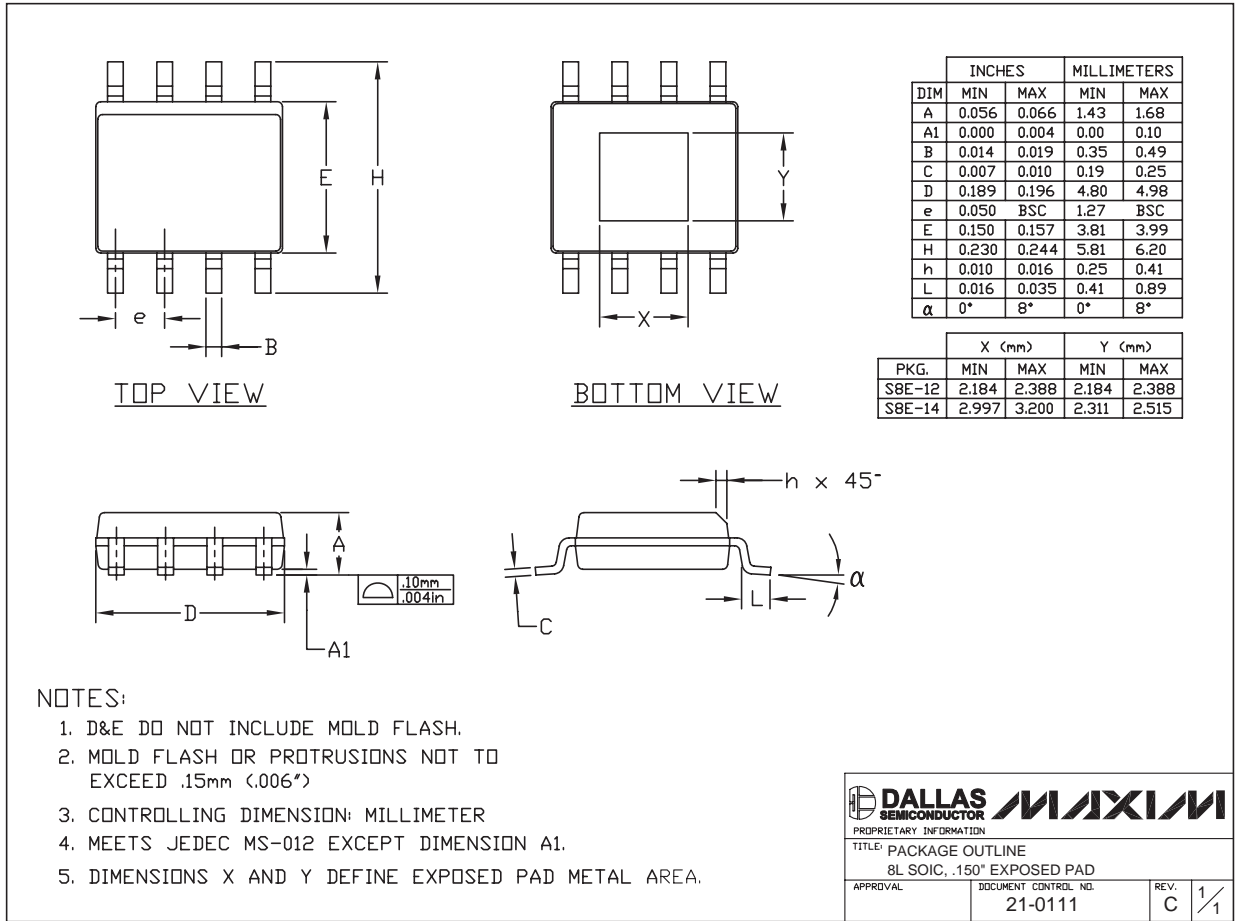

8L SOIC EXP. PAD.EPS

Maxim cannot assume responsibility for use of any circuitry other than circuitry entirely embodied in a Maxim product. No circuit patent licenses are implied. Maxim reserves the right to change the circuitry and specifications without notice at any time.

24 **Maxim Integrated Products, 120 San Gabriel Drive, Sunnyvale, CA 94086 408-737-7600**

© 2007 Maxim Integrated Products

MAXIM is a registered trademark of Maxim Integrated Products, Inc.