

M57727

144-148MHz, 12.5V, 37W, SSB MOBILE RADIO

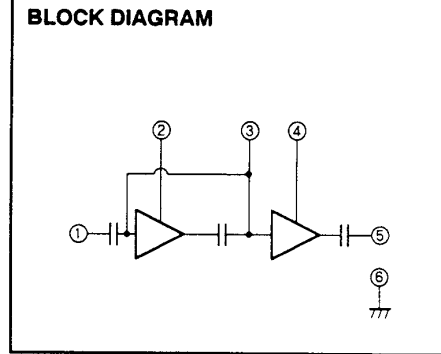
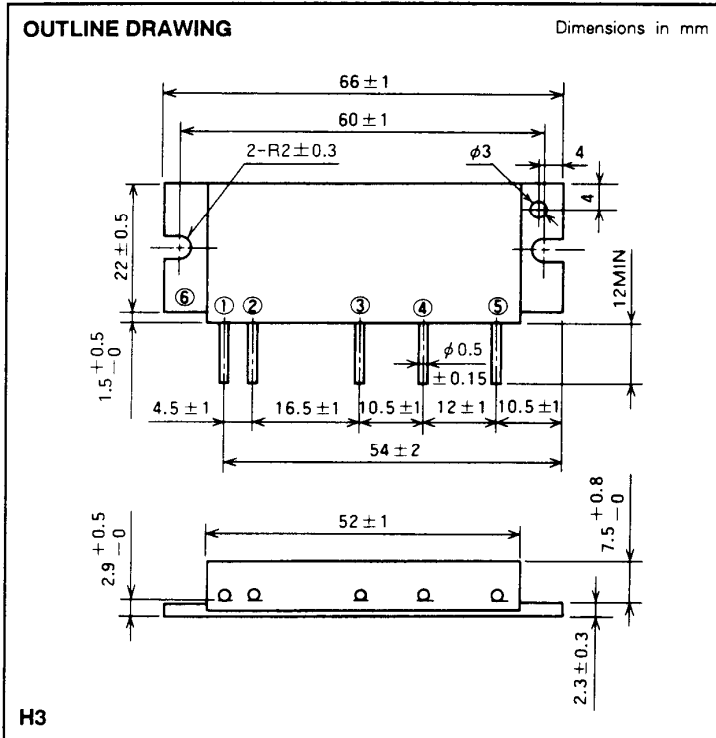

- PIN :**
- ① Pin : RF INPUT
 - ② VCC1 : 1st. DC SUPPLY
 - ③ VBB : BASE BIAS SUPPLY
 - ④ VCC2 : 2nd. DC SUPPLY
 - ⑤ Po : RF OUTPUT
 - ⑥ GND : FIN

ABSOLUTE MAXIMUM RATINGS (Tc = 25 °C unless otherwise noted)

Symbol	Parameter	Conditions	Ratings	Unit
Vcc	Supply voltage		17	V
VBB	Base bias		10	V
Icc	Total current		10	A
P _{in(max)}	Input power	Z _G = Z _L = 50 Ω	0.5	W
P _{o(max)}	Output power	Z _G = Z _L = 50 Ω	40	W
T _{C(OP)}	Operation case temperature		- 30 to 110	°C
T _{stg}	Storage temperature		- 40 to 110	°C

Note. Above parameters are guaranteed independently.

ELECTRICAL CHARACTERISTICS (Tc = 25 °C unless otherwise noted)

Symbol	Parameter	Test conditions	Limits		Unit
			Min	Max	
f	Frequency range		144	148	MHz
P _o	Output power	P _{in} = 0.3W	37		W
η _T	Total efficiency	V _{cc} = 12.5V	50		%
2f _o	2nd. harmonic	V _{BB} = 9V		- 25	dBc
3f _o	3rd. harmonic	Z _G = Z _L = 50 Ω		- 30	dBc
ρ _{in}	Input VSWR			2.2	-
-	Load VSWR tolerance	V _{cc} = 15.2V, V _{BB} = 9V P _o = 30W (P _{in} : controlled) Load VSWR ≥ 20:1 (All phase), 5sec. Z _G = 50 Ω	No degradation or destroy		-

Note. Above parameters, ratings, limits and conditions are subject to change.

TYPICAL PERFORMANCE DATA

OUTPUT POWER, TOTAL EFFICIENCY, INPUT VSWR VS. FREQUENCY

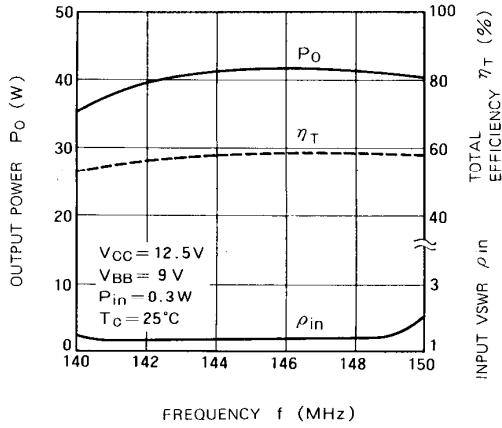

POWER GAIN VS. FREQUENCY

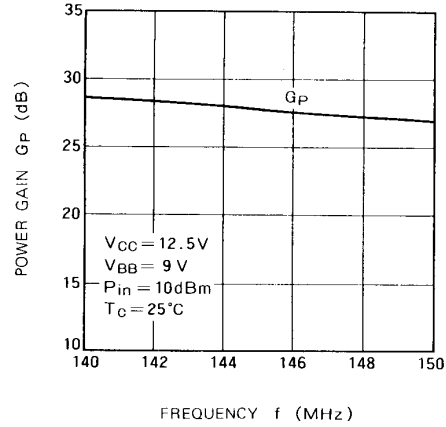

OUTPUT POWER, TOTAL COLLECTOR CURRENT VS. INPUT POWER

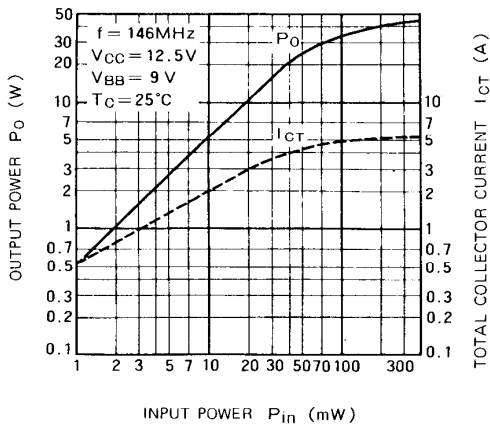

INTERMODULATION DISTORTION VS. OUTPUT POWER

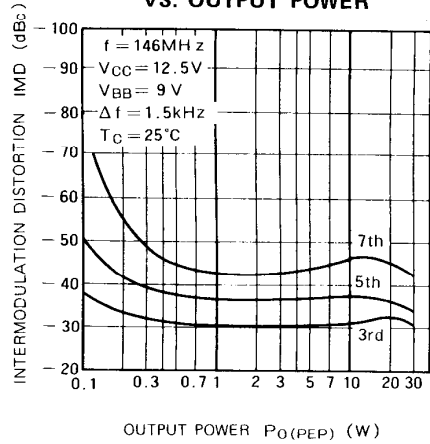

DESIGN CONSIDERATION OF HEAT RADIATION.

Please refer to following consideration when designing heat sink.

1. Junction temperature of incorporated transistors at standard operation.

(1) Thermal resistance between junction and package of incorporated transistors.

a) First stage transistor

$$R_{th(j-c)1} = 3^{\circ}\text{C/W (Typ.)}$$

b) Final stage transistor

$$R_{th(j-c)2} = 1.5^{\circ}\text{C/W (Typ.)}$$

(2) Junction temperature of incorporated transistors at standard operation.

- Conditions for standard operation.

$P_O = 30\text{W}$, $V_{CC} = 12.5\text{V}$, $P_{in} = 0.1\text{W}$, $\eta_T = 50\%$ (minimum rating), P_{O1} (Note 1) = 2W , $I_T = 4.8\text{A}$ (I_{T1} (2) = 0.4A , I_{T2} (3) = 4.4A)

Note 1: Output power of the first stage transistor

Note 2: Circuit current of the first stage transistor

Note 3: Circuit current of the final stage transistor

- Junction temperature of the first stage transistor

$$\begin{aligned} T_{j1} &= (V_{CC} \times I_{T1} - P_{O1} + P_{in}) \times R_{th(j-c)2} + T_c \text{ (4)} \\ &= (12.5 \times 0.4 - 2 + 0.1) \times 3 + T_c \\ &= 9.3 + T_c \text{ (}^{\circ}\text{C)} \end{aligned}$$

Note 4: Package temperature of device

- Junction temperature of the final stage transistor

$$\begin{aligned} T_{j2} &= (V_{CC} \times I_{T2} - P_O + P_{O1}) \times R_{th(j-c)2} + T_c \\ &= (12.5 \times 4.4 - 30 + 2) \times 1.5 + T_c \\ &= 40.5 + T_c \text{ (}^{\circ}\text{C)} \end{aligned}$$

2. Heat sink design

In thermal design of heat sink, try to keep the package temperature at the upper limit of the operating ambient temperature (normally $T_a = 60^{\circ}\text{C}$) and at the output power of 30W below 90°C .

The thermal resistance $R_{th(c-a)}$ (6) of the heat sink to realize this:

$$\begin{aligned} R_{th(c-a)} &= \frac{T_c - T_a}{(P_O/\eta_T) - P_O + P_{in}} = \frac{90 - 60}{(30/0.5) - 30 + 0.1} \\ &= 1.00 \text{ (}^{\circ}\text{C/W)} \end{aligned}$$

Note 5: Inclusive of the contact thermal resistance between device and heat sink

Mounting the heat sink of the above thermal resistance on the device,

$$T_{j1} = 110^{\circ}\text{C}, T_{j2} = 131^{\circ}\text{C at } T_a = 60^{\circ}\text{C}, T_c = 90^{\circ}\text{C.}$$

In the annual average of ambient temperature is 30°C ,

$$T_{j1} = 70^{\circ}\text{C}, T_{j2} = 101^{\circ}\text{C}$$

As the maximum junction temperature of these incorporated transistors T_{jmax} are 175°C , application under fully derated condition is ensured.