

M5269L

LOW SATURATION OUTPUT TYPE CURRENT DRIVER

DESCRIPTION

M5269L is dual Darlington current driver (semiconductor integrated circuit) which consists of PNP and NPN transistors with clamp diode and it can be driven directly from 5V-type microcomputers or logic ICs.

Low saturation output can be obtained by separating the output stage transistor's collector from the drive stage transistors.

FEATURES

- High voltage resistance $BV_{CEO} \geq 80V$
- High input voltage resistance $V_I \geq 20V$
- Large current drive $I_{C(max)} = 2.0A^*$
- Low saturation output $0.3V$ (typ) ($I_C = 0.7A$)
- Contains a clamp diode.
- Operates by the "L" level input.
- Wide operating temperature range . . . $T_a = -40^\circ C \sim +85^\circ C$
* PW = 10 ms, duty cycle $\leq 10\%$

APPLICATION

Motor drives for various relays or portable printers, digit drives for display elements such as LEDs and lamps, or power amplifiers

FUNCTION

Unlike the existing common-collector-type transistor arrays, M5269L realizes 0.3V of low saturation output voltage (typ, $I_C = 0.7A$) by separating the drive stage collector from the output stage collector. Therefore, the power dissipation which is determined by the product of the load current and the saturation output voltage can be greatly decreased.

The maximum output current is 3.0A and up to 80V can be applied as the output voltage.

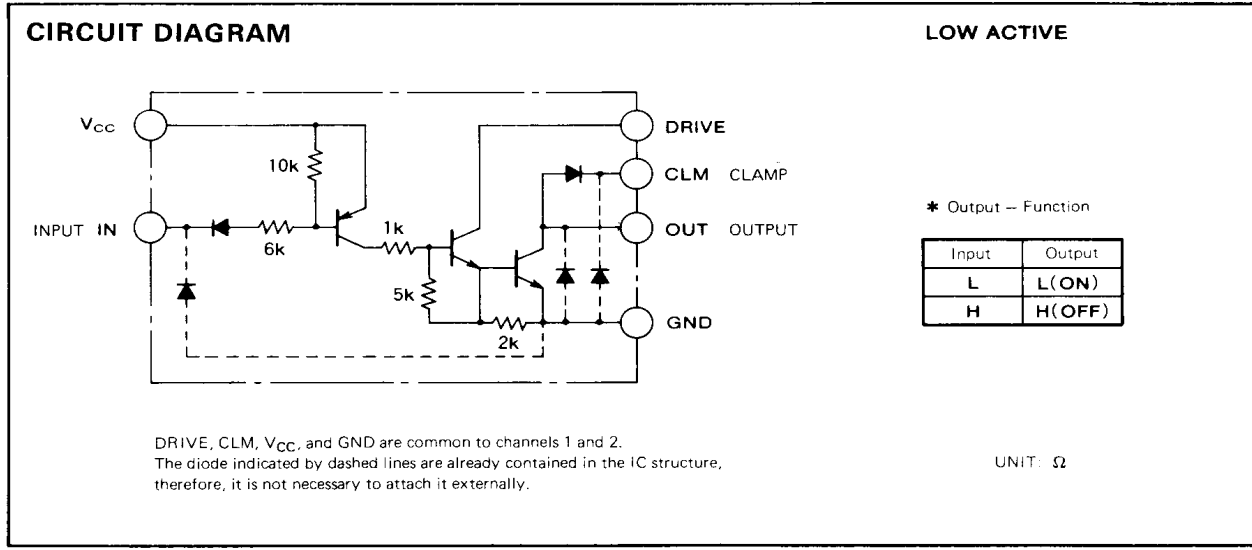
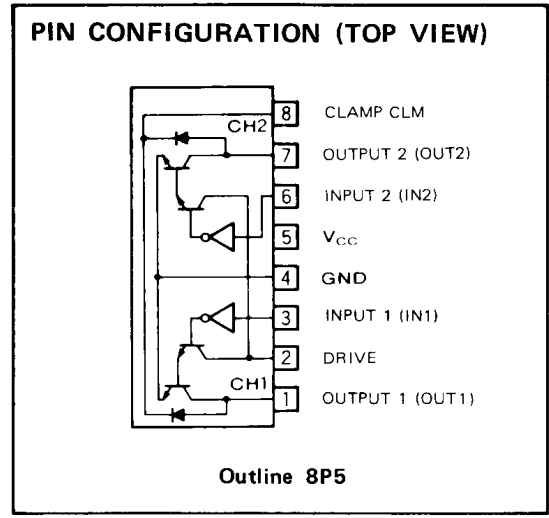

LOW SATURATION OUTPUT TYPE CURRENT DRIVER

ABSOLUTE MAXIMUM RATINGS (Ta = 25°C, unless otherwise noted)

Symbol	Parameter	Conditions	Ratings	Unit
V _{CC}	Supply voltage		20	V
V _D	Drive stage applied voltage		80	V
V _{CE}	Output voltage	When the output is "H"	80	V
V _I	Input voltage	V _{CC} = 5V	30	V
I _C	Output current	Current per circuit when the output is "L"	3.0*	A
V _R	Clamp diode reverse voltage		80	V
I _F	Clamp diode forward current		3.0	A
P _d	Power dissipation	T _a = 25°C	1, 2 (1, 7)**	W
T _{opr}	Operating temperature		-40 ~ +85	°C
T _{stg}	Storage temperature		-55 ~ +150	°C

* : PW = 10ms, duty cycle ≤ 10%

** : 400mm² of copper film is added.

RECOMMENDED OPERATING CONDITIONS (Ta = 25°C, unless otherwise noted)

Symbol	Parameter	Conditions	Limits			Unit
			Min	Typ	Max	
V _{CC}	Supply voltage		4	5	6	V
V _D	Drive stage applied voltage		4	5	70	V
V _{CE}	Output applied voltage		0		70	V
I _C	Output current	Current per circuit	0	0.7	2.0	A
V _R	Clamp diode reverse voltage		0		70	V
I _F	Clamp diode forward current		0		2.0	A
P _d	Operating temperature		0		1.0	W

ELECTRICAL CHARACTERISTICS (Ta = 25°C, value/circuit unless specified)

Symbol	Parameter	Test conditions	Limits			Unit
			Min	Typ	Max	
V _{(BR)CEO}	Output breakdown voltage	I _{CEO} = 100 μA	80			V
I _{CCH}	Output "H" supply current	V _{CC} = 6V, V _I = V _{CC}			10	μA
I _{CCL}	Output "L" supply current	V _{CC} = 6V, V _I = 0.5V			10	mA
V _{CE(sat)}	Saturation output voltage	V _{CC} = 4V V _D = 4V V _I = 0.5V I _C = 1.8A, R _D = 30 Ω		0.8	1.5	V
		I _C = 1.0A, R _D = 50 Ω		0.4	0.8	
		I _C = 0.7A, R _D = 100 Ω		0.3	0.6	
I _I	Input current	V _I = V _{CC} - 0.5V			-0.1	mA
		V _I = V _{CC} - 6V			-0.1	
I _{O(lead)}	Output lead current	V _{CE} = 80V			100	μA
I _R	Clamp diode leak current	V _R = 80V			50	μA
V _R	Clamp diode reverse voltage	I _R = 100 μA	80			V
V _F	Clamp diode forward voltage	I _F = 2.0A			3.0	V
V _{IH}	"H" input voltage	I _{O(lead)} = 50 μA	V _{CC} - 1.0			V
V _{IL}	"L" input voltage	I _C = 2.0A			V _{CC} - 3.5	V

TIMING DIAGRAM

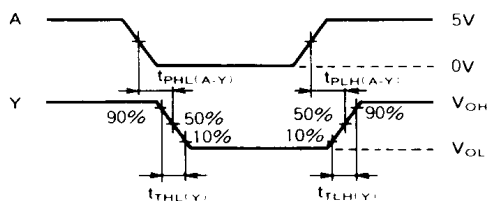

TYPICAL SPEED (Example)

t _{PHL(A-Y)}	t _{PLH(A-Y)}	t _{THL(Y)}	t _{TLH(Y)}
500ns	11 μs	130ns	20ns

LOW SATURATION OUTPUT TYPE CURRENT DRIVER

TEST CIRCUITS

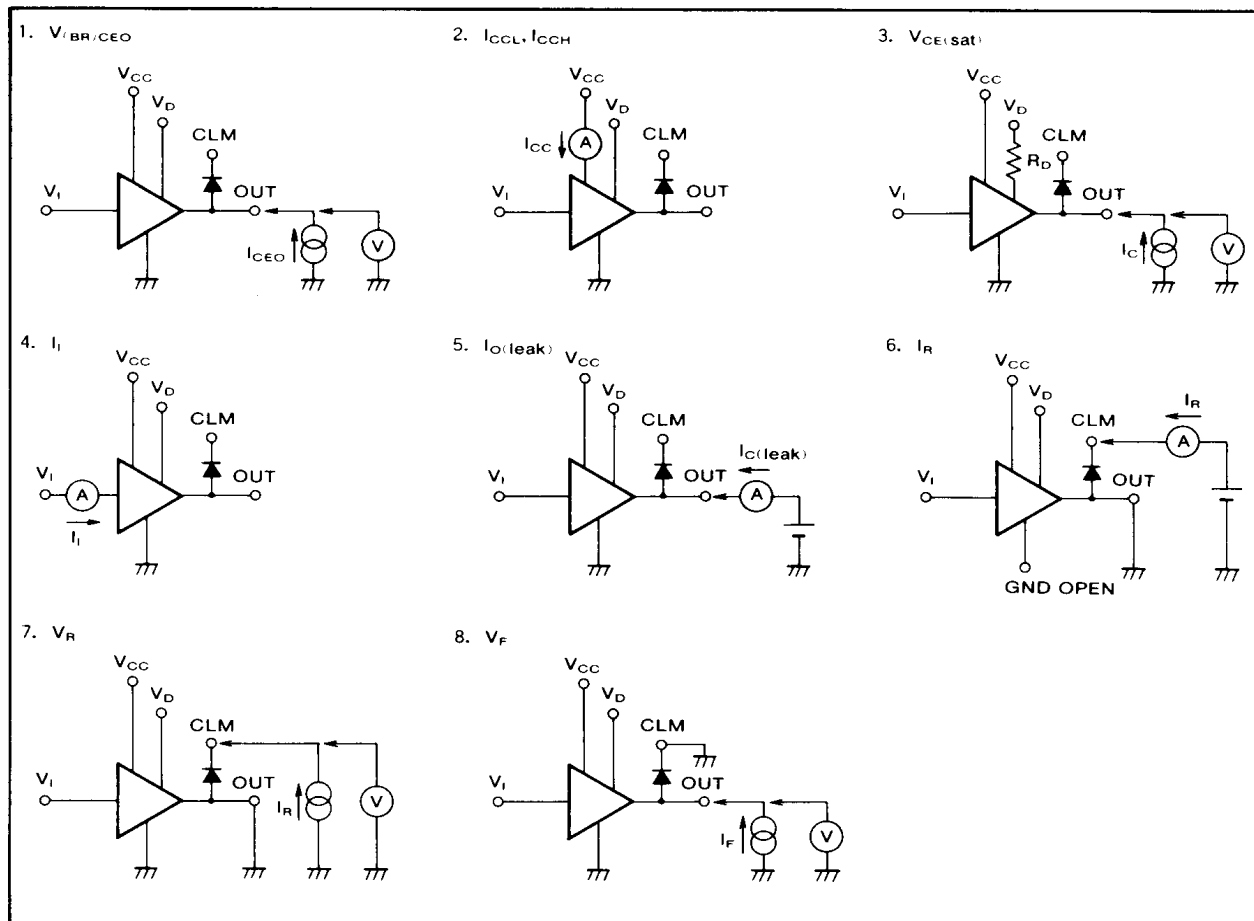

TYPICAL CHARACTERISTICS

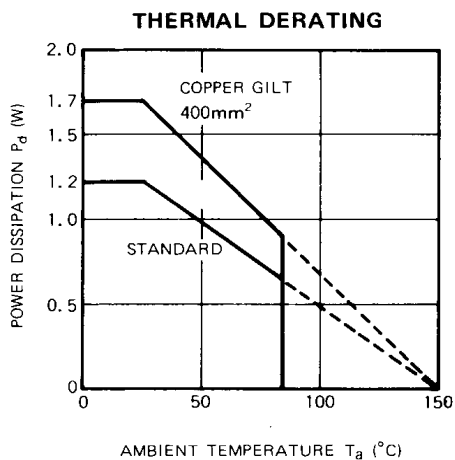

SAMPLE PCB LAYOUT

When you design a layout of a PCB, you have to consider the thermal derating. To improve the heat radiation of an IC, add a 400 mm² of copper film at the base of the GND pin. This will improve the thermal derating characteristics.

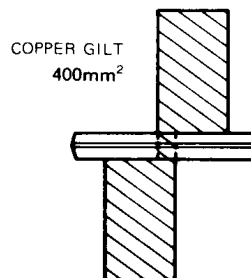

LOW SATURATION OUTPUT TYPE CURRENT DRIVER

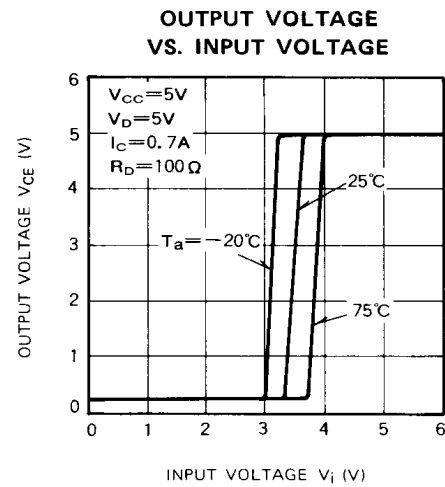
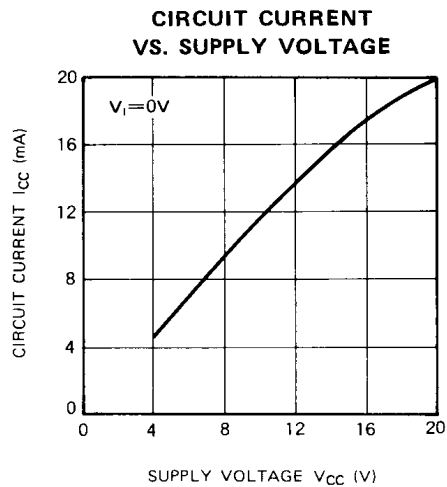
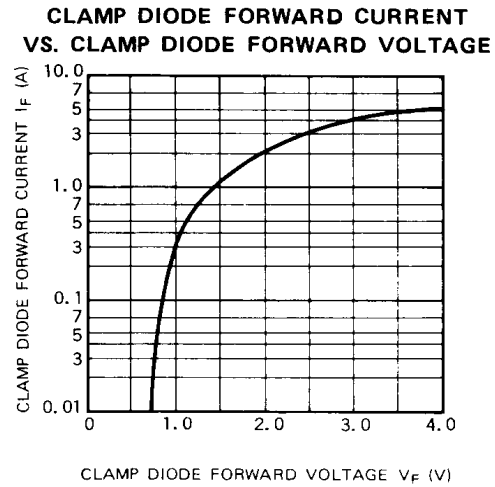
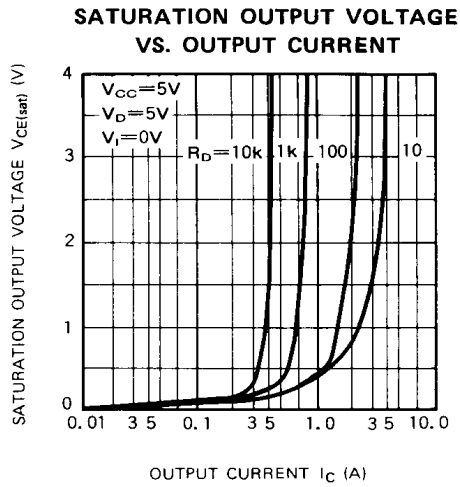
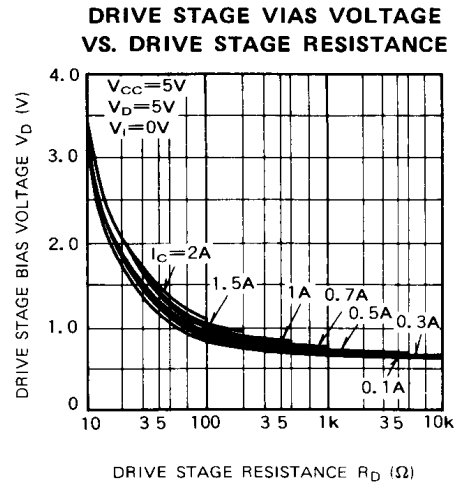
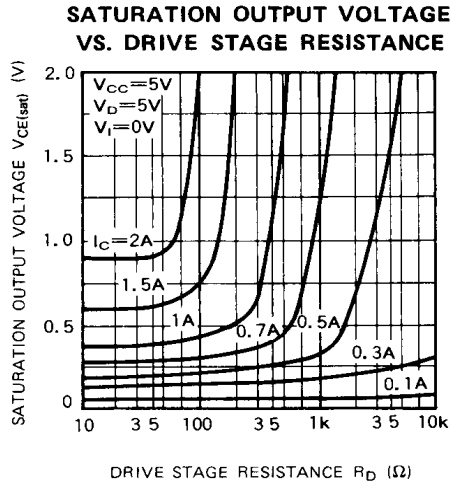

LOW SATURATION OUTPUT TYPE CURRENT DRIVER

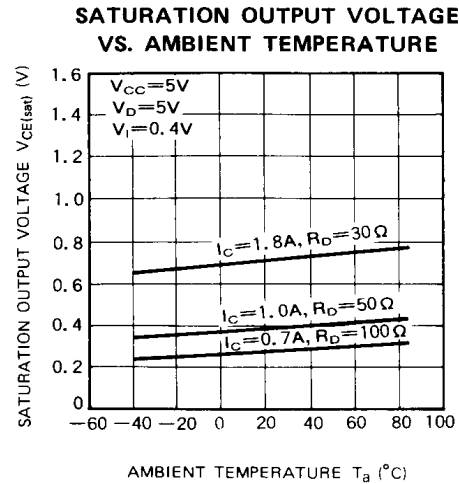
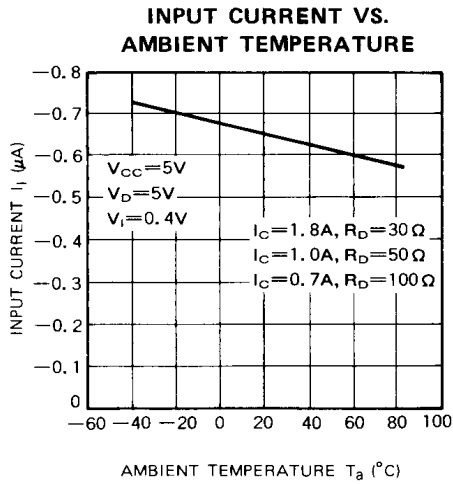

APPLICATION CIRCUIT (Stepping motor drive for a printer)

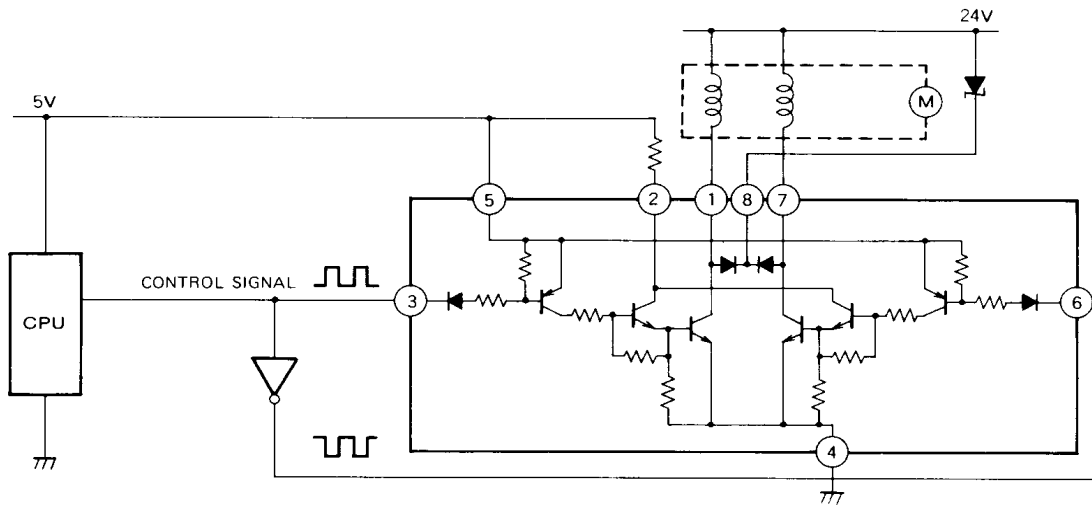

V_{CC} , DRIVE, CLAMP, AND GND ARE THE SAME FOR BOTH CIRCUITS.