

LM2601 Adapter Interface Circuit

General Description

The Adapter Interface Circuit (AIC) is used to sense the presence of an external power source for a portable computer. It notifies the computer if a source is present and indicates if the source is appropriate for charging battery packs inside the computer. The AIC also senses an adapter current and its direction. AIC isolates the adapter and signals the computer when peak current threshold is exceeded.

LM2601 drives P-channel FETs. No high current rated Schottky diode is required to implement an adapter switchover circuit. This significantly decreases additional heat dissipation during simultaneous fast battery charging while running a computer, particularly in Maximum Performance mode of operation

Features

- Detects an AC-DC adapter suitable for battery charging or an airplane or car power line adapter that should not be used for battery charging
- Allows the implementation of intelligent switchover circuits for portable systems

- LM2601 shuts down automatically when adapter is removed
- Low leakage current from battery when not powered
- Drives P-channel FETs, no Schottky diodes are required
- No reverse inrush current from battery into the adapter output capacitance
- Allows for battery capacity gas-gauge calibration under system software/firmware control
- Adapter over current threshold programmable with external resistors
- Wide input range: 5V - 24V
- Available in TSSOP-14 package

Applications

- Portable Computers
- Portable IAs (Internet Appliances, Information Appliances)
- Other Battery Powered Devices

Block Diagram

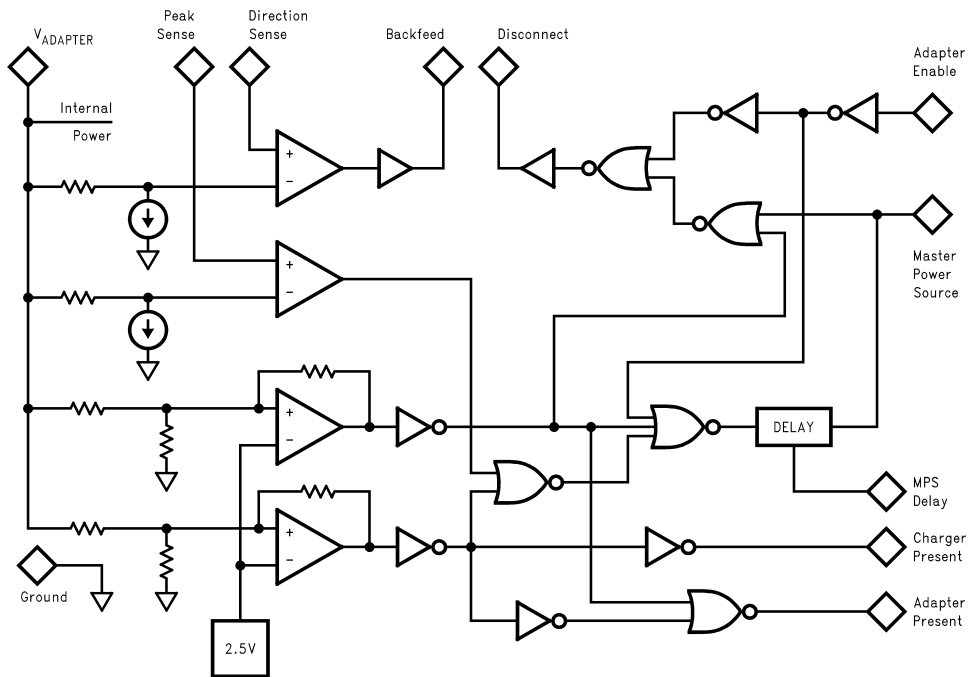

10130901

Pin Configuration

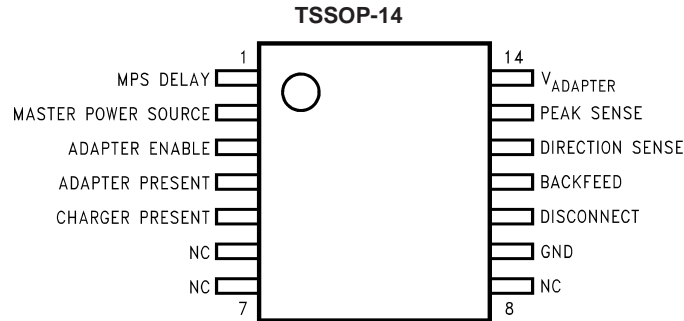

10130902

Ordering Information

Order Number	Package Number	Package Type	Supplied As*
LM2601MTC	MTC14	TSSOP-14	Rail (94 Units/Rail)
LM2601MTCX	MTC14	TSSOP-14	Tape and Reel (2500 Units/Reel)

* Partial Rails are available, there is no minimum order quantity. Tape and Reel is supplied as full reels only.

Pin Description

Pin No.	Name	Function
1	MPS DELAY	A capacitor between this pin and ground sets the delay of the MPS risetime. See MPS DELAY description in Typical Application section.
2	MASTER POWER SOURCE	Bi-directional logic pin. If driven high by an external source, indicates that a battery is powering the power bus. If driven high by the AIC, indicates the adapter is powering the bus. AIC cannot drive MPS low. If there is no valid adapter voltage present, the pin is not an output but a high impedance logic input. The input is pulled-down via an internal 40k resistor.
3	ADAPTER ENABLE	Logic input pin. Active high. Grants permission to the adapter to drive both the power bus and the MPS signal.
4	ADAPTER PRESENT	Logic output pin. High when $12 \text{ volts} < V_{\text{ADAPTER}} < 17 \text{ volts}$. The output typically has 40k pull-down resistor. The source current is not internally limited and the part can be damaged if the output is shorted to ground when driven HIGH.
5	CHARGER PRESENT	Logic output pin. High when $V_{\text{ADAPTER}} > 17 \text{ volts}$. The output typically has 40k pull-down resistor. The source current is not internally limited and the part can be damaged if the output is shorted to ground when driven HIGH.
9	GND	IC ground pin.
10	DISCONNECT	Drives the gate of the disconnect P-ch FET.
11	BACKFEED	Drives the gate of the backfeed P-ch FET.
12	DIRECTION SENSE	Connection for current sense resistor to control BACKFEED.
13	PEAK SENSE	Connection for current sense resistor to control DISCONNECT.
14	V_{ADAPTER}	Power input pin. Output of AC adapter, auto adapter or airline adapter.

Absolute Maximum Ratings (Note 1)

If Military/Aerospace specified devices are required, please contact the National Semiconductor Sales Office/Distributors for availability and specifications.

$V_{ADAPTER}$	-0.3V to 28V
$V_{PEAK\ SENSE}, V_{DIRECTION\ SENSE}, V_{BACKFEED}, V_{DISCONNECT}$	-0.3V to $V_{ADAPTER}$
$V_{ADAPTER\ ENABLE}, V_{MASTER\ POWER\ SOURCE}$	-0.3V to 5.5V
$V_{MPS\ DELAY}$	-0.3V to 2V

Storage Temperature	-40°C to 125°C
ESD Ratings	
Human Body Model (Note 2)	2kV
Machine Model (Note 3)	200V

Operating Ratings (Note 1)

Supply Voltage ($V_{ADAPTER}$)	5V to 24V
Ambient Temp. Range	-20°C to 70°C
Junction Temp. Range	-20°C to 85°C

Electrical Characteristics

Limits with standard typeface apply for $T_J = 25^\circ\text{C}$, and limits in **boldface type** apply over the full temperature range (Note 4)

Symbol	Parameter	Conditions	Min	Typ	Max	Units
V_{AE}	Adapter Enable - 3V- or 5V-CMOS or TTL Logic Input	High Low	2.0		0.8	V
$V_{AP, CP}$	Logic Output Voltage Adapter present, Charger present	High Low, $I_{SINK} = 5\mu\text{A}$	2.9	3.1 0.25	0.6	V
V_{MPSI}	Master Power Source 5V-CMOS Logic Input	High Low	4.0		0.8	V
V_{MPSO}	Logic Output Voltage Master Power Source	$V_{ADAPTER} > 5.8\text{V}$ High Low	4.5	4.75 0.05	0.5	V
$V_{ADAPTER}$	Adapter Voltage for V_{AP} Low-to-High Transition		11.7	12.0	12.3	V
	Hysteresis		1.8	2.0	2.2	
$V_{CHARGER}$	Adapter Voltage for V_{CP} Low-to-High Transition		16.5	17.0	17.4	V
	Hysteresis		0.08	0.10	0.12	
$\Delta V_{BACKFEED}$	Current Sense Differential Voltage Threshold for Driving Backfeed FET	$V_{ADAPTER}$ - Direction sense, $V_{ADAPTER} = 5\text{V}$	4 3	9	17 18	mV
$\Delta V_{DISCONNECT}$	Current Sense Differential Voltage Threshold for Driving Disconnect FET	$V_{ADAPTER}$ - Peak sense, $V_{ADAPTER} = 24\text{V}$	127 125	135	143 145	mV
$V_{BACKFEED}, V_{DISCONNECT}$	FET Control Voltage	$V_{ADAPTER} > 11\text{V}$ High $V_{ADAPTER} > 11\text{V}$ Low		$V_{ADAPTER} - 0.5\text{V}$ $V_{ADAPTER} - 10\text{V}$ or GND+0.5V, whichever is greater		V
t_{DRIVE}	Rise/Fall Time of FET Drive (Note 5)	$V_{ADAPTER} = 10\text{V}$ $C_{Load} = 3000\text{pF}$		3	6	μS
I_Q	Quiescent Current	$V_{ADAPTER} = 24\text{V}$		2	10	mA
$I_{L,B}, I_{L,D}$	Leakage Current into Backfeed or Disconnect	$V_{ADAPTER} = 0\text{V}$ $V_{BACKFEED}, V_{DISCONNECT} = 18\text{V}$		1	15	μA
$I_{L,AE}$	Input Current into Adapter Enable Input	$V_{AE} = 3.3\text{V}$, Backfeed/Disconnect = 18V		50		μA
$I_{L,MPS}$	Input Current into MPS Input	$V_{MPS} = 5.5\text{V}$		175		μA
TC_{DELAY}	Delay Time Temperature Coefficient			4000		ppm/°C

Note 1: Absolute Maximum Ratings indicate limits beyond which damage to the device may occur. Operating Ratings indicate conditions for which the device is intended to be functional, but do not guarantee specific performance limits. For guaranteed specifications and test conditions, see the Electrical Characteristics.

Note 2: The human body model is a 100pF capacitor discharged through a 1.5k Ω resistor into each pin.

Note 3: The machine model is a 200pF capacitor discharged directly into each pin. All pins are rated for 200V except pins 4 and 5 which are rated for 100V.

Note 4: Datasheet min/max specification limits are guaranteed by design, test, or statistical analysis.

Electrical Characteristics (Continued)

Note 5: Adapter Enable input is used to change the state of Disconnect, Direction Sense input is used to change the state of Backfeed.

- Fall time is measured as the time it takes Backfeed or Disconnect voltage to go from a high level (approx. $V_{ADAPTER} - 0.5V$) to $(V_{ADAPTER} - 4V)$ after the signal is initiated at Adapter Enable or Direction Sense.
- Rise time is measured as the time it takes Backfeed or Disconnect voltage to go from a low level (approx. $0.5V$) to $(V_{ADAPTER} - 2V)$ after the signal is initiated at Adapter Enable or Direction Sense.

Typical Application

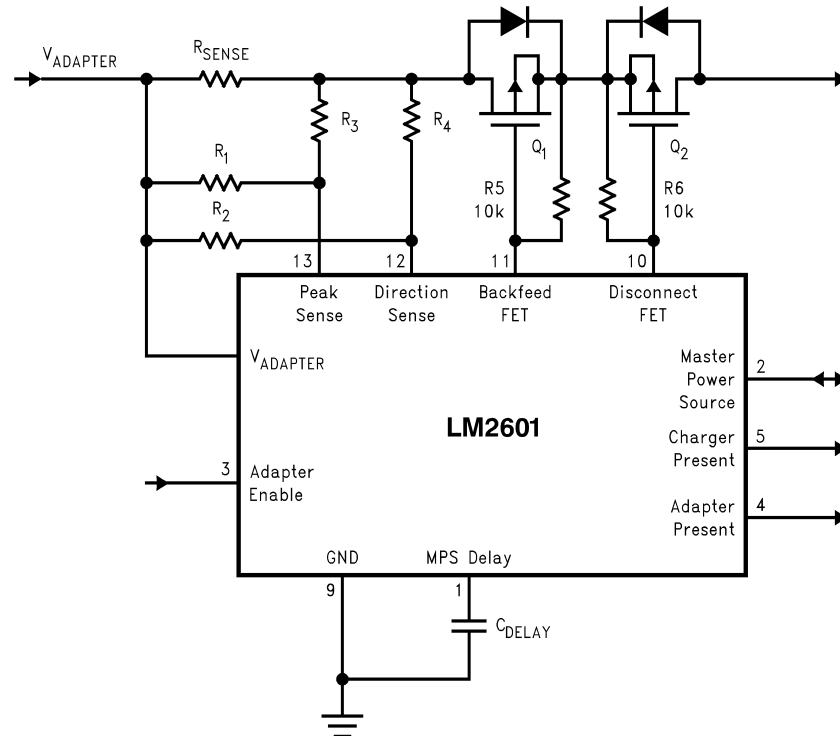

10130903

Notes

- R_{SENSE} value should be selected to guarantee that a programmed over current will cause a voltage drop across R_{SENSE} of approx. 135mV. If a higher value of R_{SENSE} has to be selected then R1/R3 resistor divider should be used to scale the voltage drop down.
- Internal and external circuits associated with Direction Sense and Backfeed FET pins allow to emulate a Schottky diode functionality with much lower forward voltage drop and, therefore, with much lower power dissipation. R2/R4 resistor divider programs the backfeed current protection threshold. The backfeed FET Q1 turns off when the backfeed current pulse level causes more than 9 mV (typical value) voltage drop between $V_{ADAPTER}$ pin and Direction Sense pin.
- Voltage difference ($V_{DIRECTION\ SENSE} - V_{ADAPTER}$) must be higher than 20mV to reliably isolate the adapter in case of leakage.
- R5 and R6 prevent the FETs from turning on unless driven by LM2601.
- C_{DELAY} value can be calculated from the following formula:

$$C_{DELAY}(nF) = T_{DELAY}(\mu s) / 90 \text{ at } 25^{\circ}C$$
- T_{DELAY} temperature coefficient equals 4000ppm/ $^{\circ}C$. See also the Typical Delay Time vs. Temperature graph.
- Pin Master Power Source (MPS) should be connected to System Management Controller's (SMC) and battery packs' GPIOs. When SMC detects a powered AC adapter via active signals at Charger Present or Adapter Present outputs, it asserts Adapter Enable signal and isolates the battery pack(s). Adapter Enable signal turns the Disconnect FET on. When the AC adapter is unplugged or powered off, SMC enables one of the system battery packs. The battery packs' embedded controller starts driving the logic MPS signal high that turns the Disconnect FET off.

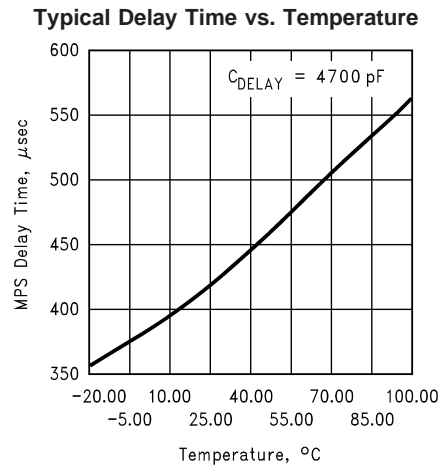

Application Information

The adapter interface circuit (AIC) IC provides the control functions necessary for use in mating a constant voltage output AC-DC adapter or airline adapter to a notebook computer system or a portable device. It allows optimal battery charging during computer operation, and allows battery discharge for battery gas gauge calibration. It receives control signals from the notebook computer, monitors input current from the adapter, provides adapter voltage status to the notebook system management microcontroller (or "embedded controller"), and appropriately drives MOSFET switches to electrically connect the adapter to the computer.

AIC will allow a system designer to solve various power management tasks typical for an adapter powered systems containing a rechargeable battery.

When a notebook computer is being powered from a battery and the adapter is plugged in, the computer should start drawing power from the adapter, not from the battery. The most time efficient charging scenario is when a computer draws the full rated current from a constant voltage adapter. The computer uses what it needs to run, and passes all remaining power on to the battery for charging. The computer should be able to automatically refuse to charge a battery when powered from an airplane power line. It may be

necessary sometimes to have a computer fully discharging the battery and then fully recharging it (for battery gas gauge calibration purposes) while being powered by an AC adapter.

AIC will also allow a computer to prevent backfeeding current into an adapter if the adapter is not powered while being plugged into the computer (some of existing adapters can draw current from the computer under this conditions for charging the AC adapter output bulk capacitance from the computer battery).

While the lowest usable adapter voltage is about 9.5V, that is $V_{ADAPTER} = 11.7V$ minus 2.2V hysteresis, AIC is operational down to $V_{ADAPTER} = 5V$. This means that AIC will not generate false readings down to $V_{ADAPTER} = 5V$. Such false readings would be MPS = HIGH, ADAPTER PRESENT = HIGH, CHARGER PRESENT = HIGH.

AIC determines usable voltage ranges by comparing $V_{ADAPTER}$ with an internal 2.5V voltage reference (see also Electrical Characteristics). AIC detects operating current limit and leakage current limit into the adapter jack by differential sensing across current sense resistor R_{SENSE} either directly or scaled down by resistor dividers R1/R3 and R2/R4.

When designing the LM2601 into a system it may be necessary to consider ESD protection requirements for the adapter jack according to your system design spec.

Physical Dimensions inches (millimeters)

unless otherwise noted

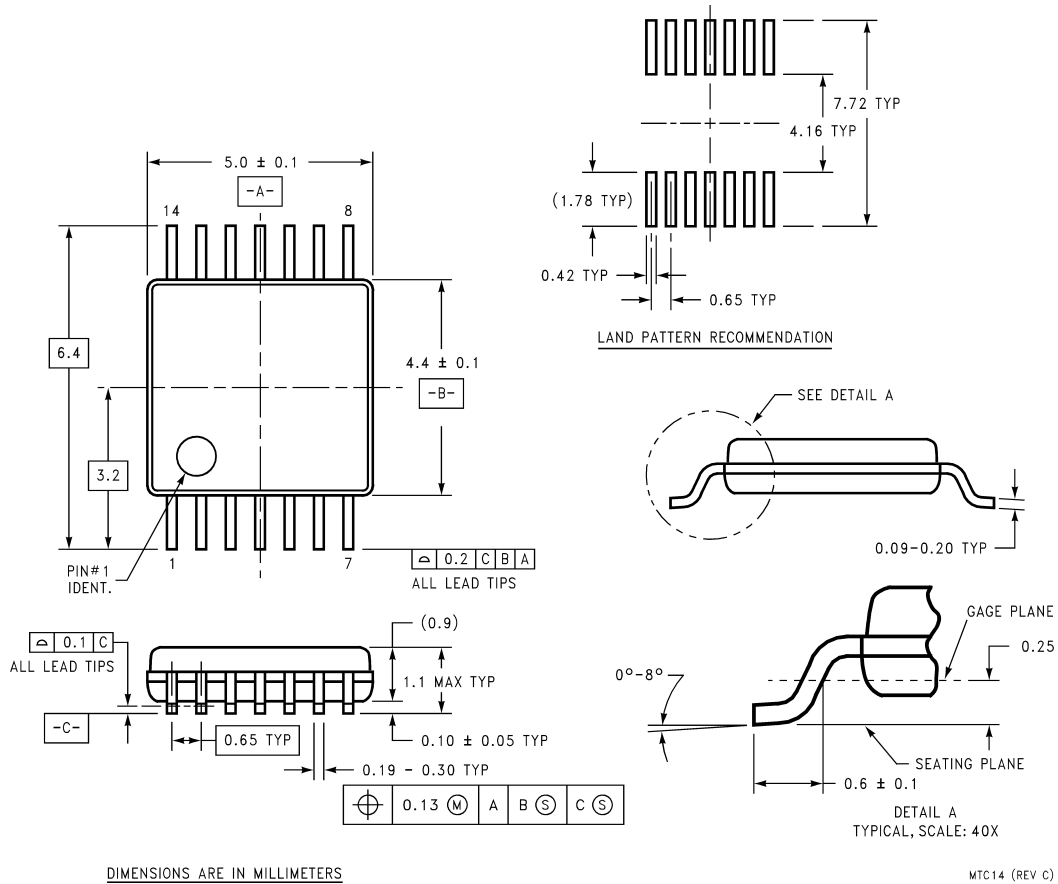

TSSOP-14 Package
14-Lead Thin Shrink Small-Outline Package
For Ordering, Refer to Ordering Information Table
NS Package Number MTC14

LIFE SUPPORT POLICY

NATIONAL'S PRODUCTS ARE NOT AUTHORIZED FOR USE AS CRITICAL COMPONENTS IN LIFE SUPPORT DEVICES OR SYSTEMS WITHOUT THE EXPRESS WRITTEN APPROVAL OF THE PRESIDENT AND GENERAL COUNSEL OF NATIONAL SEMICONDUCTOR CORPORATION. As used herein:

1. Life support devices or systems are devices or systems which, (a) are intended for surgical implant into the body, or (b) support or sustain life, and whose failure to perform when properly used in accordance with instructions for use provided in the labeling, can be reasonably expected to result in a significant injury to the user.
2. A critical component is any component of a life support device or system whose failure to perform can be reasonably expected to cause the failure of the life support device or system, or to affect its safety or effectiveness.



National Semiconductor Corporation
Americas
Tel: 1-800-272-9959
Fax: 1-800-737-7018
Email: support@nsc.com
www.national.com

National Semiconductor Europe
Fax: +49 (0) 180-530 85 86
Email: europe.support@nsc.com
Deutsch Tel: +49 (0) 69 9508 6208
English Tel: +44 (0) 870 24 0 2171
Français Tel: +33 (0) 1 41 91 8790

National Semiconductor Asia Pacific Customer Response Group
Tel: 65-2544466
Fax: 65-2504466
Email: ap.support@nsc.com

National Semiconductor Japan Ltd.
Tel: 81-3-5639-7560
Fax: 81-3-5639-7507