

# IS41C16100 IS41LV16100



## 1M x 16 (16-MBIT) DYNAMIC RAM WITH EDO PAGE MODE

December 2005

### FEATURES

- TTL compatible inputs and outputs; tristate I/O
- Refresh Interval:
  - *Auto refresh Mode*: 1,024 cycles / 16 ms
  - *RAS-Only, CAS-before-RAS (CBR), and Hidden*
  - *Self refresh Mode* - 1,024 cycles / 128ms
- JEDEC standard pinout
- Single power supply:
  - 5V ± 10% (IS41C16100)
  - 3.3V ± 10% (IS41LV16100)
- Byte Write and Byte Read operation via two  $\overline{\text{CAS}}$
- Industrial Temperature Range -40°C to 85°C
- Lead-free available

### PIN CONFIGURATIONS

50(44)-Pin TSOP (Type II)

42-Pin SOJ

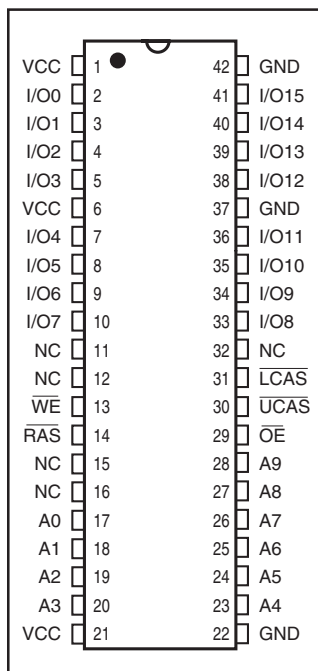
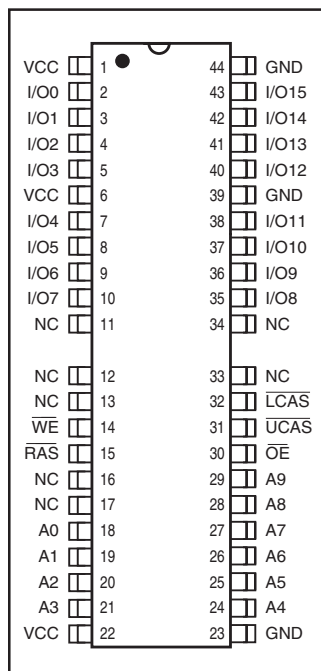

### DESCRIPTION

The ISSI IS41C16100 and IS41LV16100 are 1,048,576 x 16-bit high-performance CMOS Dynamic Random Access Memories. These devices offer an accelerated cycle access called EDO Page Mode. EDO Page Mode allows 1,024 random accesses within a single row with access cycle time as short as 20 ns per 16-bit word. The Byte Write control, of upper and lower byte, makes the IS41C16100 ideal for use in 16-bit and 32-bit wide data bus systems.

These features make the IS41C16100 and IS41LV16100 ideally suited for high-bandwidth graphics, digital signal processing, high-performance computing systems, and peripheral applications.

The IS41C16100 and IS41LV16100 are packaged in a 42-pin 400-mil SOJ and 400-mil 50- (44-) pin TSOP (Type II). The lead-free 400-mil 50- (44-) option is available too.

### KEY TIMING PARAMETERS

Parameter	-50	-60	Unit
Max. $\overline{\text{RAS}}$ Access Time ( $t_{\text{RAC}}$ )	50	60	ns
Max. $\overline{\text{CAS}}$ Access Time ( $t_{\text{CAC}}$ )	13	15	ns
Max. Column Address Access Time ( $t_{\text{AA}}$ )	25	30	ns
Min. EDO Page Mode Cycle Time ( $t_{\text{PC}}$ )	20	25	ns
Min. Read/Write Cycle Time ( $t_{\text{RC}}$ )	84	104	ns

### PIN DESCRIPTIONS

A0-A9	Address Inputs
I/O0-15	Data Inputs/Outputs
$\overline{\text{WE}}$	Write Enable
$\overline{\text{OE}}$	Output Enable
$\overline{\text{RAS}}$	Row Address Strobe
$\overline{\text{UCAS}}$	Upper Column Address Strobe
$\overline{\text{LCAS}}$	Lower Column Address Strobe
Vcc	Power
GND	Ground
NC	No Connection

Copyright © 2005 Integrated Silicon Solution, Inc. All rights reserved. ISSI reserves the right to make changes to this specification and its products at any time without notice. ISSI assumes no liability arising out of the application or use of any information, products or services described herein. Customers are advised to obtain the latest version of this device specification before relying on any published information and before placing orders for products.

Integrated Silicon Solution, Inc. — [www.issi.com](http://www.issi.com) — 1-800-379-4774

Rev. L  
12/22/05

FUNCTIONAL BLOCK DIAGRAM

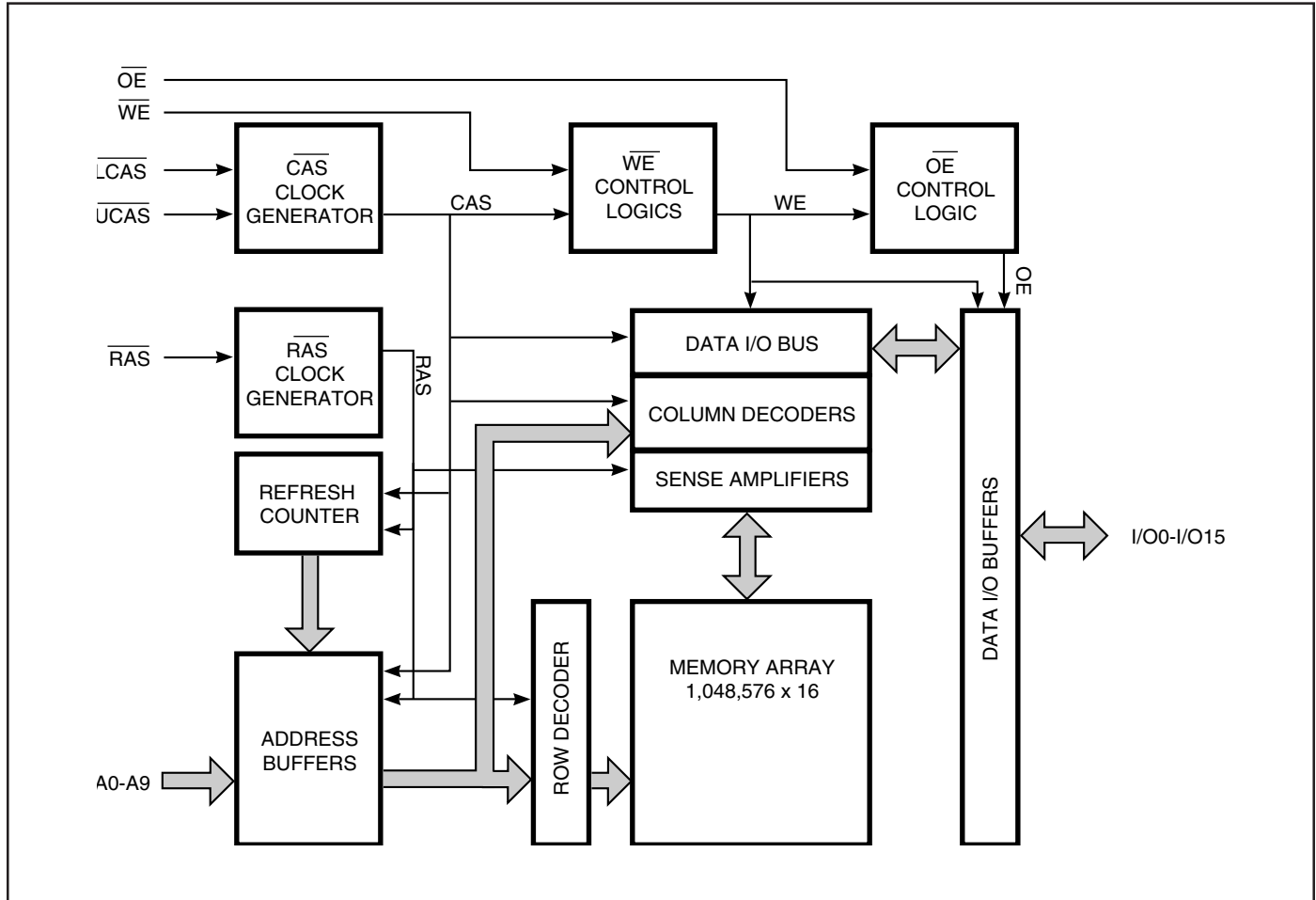

TRUTH TABLE

Function		$\overline{\text{RAS}}$	$\overline{\text{LCAS}}$	$\overline{\text{UCAS}}$	$\overline{\text{WE}}$	$\overline{\text{OE}}$	Address tr/tc	I/O
Standby		H	H	H	X	X	X	High-Z
Read: Word		L	L	L	H	L	ROW/COL	DOUT
Read: Lower Byte		L	L	H	H	L	ROW/COL	Lower Byte, DOUT Upper Byte, High-Z
Read: Upper Byte		L	H	L	H	L	ROW/COL	Lower Byte, High-Z Upper Byte, DOUT
Write: Word (Early Write)		L	L	L	L	X	ROW/COL	DIN
Write: Lower Byte (Early Write)		L	L	H	L	X	ROW/COL	Lower Byte, DIN Upper Byte, High-Z
Write: Upper Byte (Early Write)		L	H	L	L	X	ROW/COL	Lower Byte, High-Z Upper Byte, DIN
Read-Write <sup>(1,2)</sup>		L	L	L	H→L	L→H	ROW/COL	DOUT, DIN
EDO Page-Mode Read <sup>(2)</sup>	1st Cycle:	L	H→L	H→L	H	L	ROW/COL	DOUT
	2nd Cycle:	L	H→L	H→L	H	L	NA/COL	DOUT
	Any Cycle:	L	L→H	L→H	H	L	NA/NA	DOUT
EDO Page-Mode Write <sup>(1)</sup>	1st Cycle:	L	H→L	H→L	L	X	ROW/COL	DIN
	2nd Cycle:	L	H→L	H→L	L	X	NA/COL	DIN
EDO Page-Mode <sup>(1,2)</sup> Read-Write	1st Cycle:	L	H→L	H→L	H→L	L→H	ROW/COL	DOUT, DIN
	2nd Cycle:	L	H→L	H→L	H→L	L→H	NA/COL	DOUT, DIN
Hidden Refresh	Read <sup>(2)</sup>	L→H→L	L	L	H	L	ROW/COL	DOUT
	Write <sup>(1,3)</sup>	L→H→L	L	L	L	X	ROW/COL	DOUT
$\overline{\text{RAS}}$ -Only Refresh		L	H	H	X	X	ROW/NA	High-Z
CBR Refresh <sup>(4)</sup>		H→L	L	L	X	X	X	High-Z

Notes:

1. These WRITE cycles may also be BYTE WRITE cycles (either  $\overline{\text{LCAS}}$  or  $\overline{\text{UCAS}}$  active).
2. These READ cycles may also be BYTE READ cycles (either  $\overline{\text{LCAS}}$  or  $\overline{\text{UCAS}}$  active).
3. EARLY WRITE only.
4. At least one of the two  $\overline{\text{CAS}}$  signals must be active ( $\overline{\text{LCAS}}$  or  $\overline{\text{UCAS}}$ ).

## Functional Description

The IS41C16100 and IS41LV16100 is a CMOS DRAM optimized for high-speed bandwidth, low power applications. During READ or WRITE cycles, each bit is uniquely addressed through the 16 address bits. These are entered ten bits (A0-A9) at a time. The row address is latched by the Row Address Strobe ( $\overline{\text{RAS}}$ ). The column address is latched by the Column Address Strobe ( $\overline{\text{CAS}}$ ).  $\overline{\text{RAS}}$  is used to latch the first nine bits and  $\overline{\text{CAS}}$  is used to latch the latter nine bits.

The IS41C16100 and IS41LV16100 has two  $\overline{\text{CAS}}$  controls,  $\overline{\text{LCAS}}$  and  $\overline{\text{UCAS}}$ . The  $\overline{\text{LCAS}}$  and  $\overline{\text{UCAS}}$  inputs internally generate a  $\overline{\text{CAS}}$  signal functioning in an identical manner to the single  $\overline{\text{CAS}}$  input on the other 1M x 16 DRAMs. The key difference is that each  $\overline{\text{CAS}}$  controls its corresponding I/O tristate logic (in conjunction with  $\overline{\text{OE}}$  and  $\overline{\text{WE}}$  and  $\overline{\text{RAS}}$ ).  $\overline{\text{LCAS}}$  controls I/O0 through I/O7 and  $\overline{\text{UCAS}}$  controls I/O8 through I/O15.

The IS41C16100 and IS41LV16100  $\overline{\text{CAS}}$  function is determined by the first  $\overline{\text{CAS}}$  ( $\overline{\text{LCAS}}$  or  $\overline{\text{UCAS}}$ ) transitioning LOW and the last transitioning back HIGH. The two  $\overline{\text{CAS}}$  controls give the IS41C16100 and IS41LV16100 both BYTE READ and BYTE WRITE cycle capabilities.

## Memory Cycle

A memory cycle is initiated by bringing  $\overline{\text{RAS}}$  LOW and it is terminated by returning both  $\overline{\text{RAS}}$  and  $\overline{\text{CAS}}$  HIGH. To ensure proper device operation and data integrity any memory cycle, once initiated, must not be ended or aborted before the minimum  $t_{\text{RAS}}$  time has expired. A new cycle must not be initiated until the minimum precharge time  $t_{\text{RP}}$ ,  $t_{\text{CP}}$  has elapsed.

## Read Cycle

A read cycle is initiated by the falling edge of  $\overline{\text{CAS}}$  or  $\overline{\text{OE}}$ , whichever occurs last, while holding  $\overline{\text{WE}}$  HIGH. The column address must be held for a minimum time specified by  $t_{\text{AR}}$ . Data Out becomes valid only when  $t_{\text{RAC}}$ ,  $t_{\text{AA}}$ ,  $t_{\text{CAC}}$  and  $t_{\text{OEA}}$  are all satisfied. As a result, the access time is dependent on the timing relationships between these parameters.

## Write Cycle

A write cycle is initiated by the falling edge of  $\overline{\text{CAS}}$  and  $\overline{\text{WE}}$ , whichever occurs last. The input data must be valid at or before the falling edge of  $\overline{\text{CAS}}$  or  $\overline{\text{WE}}$ , whichever occurs first.

## Auto Refresh Cycle

To retain data, 1,024 refresh cycles are required in each 16 ms period. There are two ways to refresh the memory.

1. By clocking each of the 1,024 row addresses (A0 through A9) with  $\overline{\text{RAS}}$  at least once every 128 ms. Any read, write, read-modify-write or  $\overline{\text{RAS}}$ -only cycle refreshes the addressed row.
2. Using a  $\overline{\text{CAS}}$ -before- $\overline{\text{RAS}}$  refresh cycle.  $\overline{\text{CAS}}$ -before- $\overline{\text{RAS}}$  refresh is activated by the falling edge of  $\overline{\text{RAS}}$ ,

while holding  $\overline{\text{CAS}}$  LOW. In  $\overline{\text{CAS}}$ -before- $\overline{\text{RAS}}$  refresh cycle, an internal 9-bit counter provides the row addresses and the external address inputs are ignored.

$\overline{\text{CAS}}$ -before- $\overline{\text{RAS}}$  is a refresh-only mode and no data access or device selection is allowed. Thus, the output remains in the High-Z state during the cycle.

## Self Refresh Cycle

The Self Refresh allows the user a dynamic refresh, data retention mode at the extended refresh period of 128 ms. i.e., 125  $\mu\text{s}$  per row when using distributed CBR refreshes. The feature also allows the user the choice of a fully static, low power data retention mode. The optional Self Refresh feature is initiated by performing a CBR Refresh cycle and holding  $\overline{\text{RAS}}$  LOW for the specified  $t_{\text{RAS}}$ .

The Self Refresh mode is terminated by driving  $\overline{\text{RAS}}$  HIGH for a minimum time of  $t_{\text{RP}}$ . This delay allows for the completion of any internal refresh cycles that may be in process at the time of the  $\overline{\text{RAS}}$  LOW-to-HIGH transition. If the DRAM controller uses a distributed refresh sequence, a burst refresh is not required upon exiting Self Refresh.

However, if the DRAM controller utilizes a  $\overline{\text{RAS}}$ -only or burst refresh sequence, all 1,024 rows must be refreshed within the average internal refresh rate, prior to the resumption of normal operation.

## Extended Data Out Page Mode

EDO page mode operation permits all 1,024 columns within a selected row to be randomly accessed at a high data rate.

In EDO page mode read cycle, the data-out is held to the next  $\overline{\text{CAS}}$  cycle's falling edge, instead of the rising edge. For this reason, the valid data output time in EDO page mode is extended compared with the fast page mode. In the fast page mode, the valid data output time becomes shorter as the  $\overline{\text{CAS}}$  cycle time becomes shorter. Therefore, in EDO page mode, the timing margin in read cycle is larger than that of the fast page mode even if the  $\overline{\text{CAS}}$  cycle time becomes shorter.

In EDO page mode, due to the extended data function, the  $\overline{\text{CAS}}$  cycle time can be shorter than in the fast page mode if the timing margin is the same.

The EDO page mode allows both read and write operations during one  $\overline{\text{RAS}}$  cycle, but the performance is equivalent to that of the fast page mode in that case.

## Power-On

After application of the  $V_{\text{CC}}$  supply, an initial pause of 200  $\mu\text{s}$  is required followed by a minimum of eight initialization cycles (any combination of cycles containing a  $\overline{\text{RAS}}$  signal).

During power-on, it is recommended that  $\overline{\text{RAS}}$  track with  $V_{\text{CC}}$  or be held at a valid  $V_{\text{IH}}$  to avoid current surges.

**ABSOLUTE MAXIMUM RATINGS<sup>(1)</sup>**

Symbol	Parameters	Rating	Unit	
V <sub>T</sub>	Voltage on Any Pin Relative to GND	5V	-1.0 to +7.0	V
		3.3V	-0.5 to +4.6	
V <sub>CC</sub>	Supply Voltage	5V	-1.0 to +7.0	V
		3.3V	-0.5 to +4.6	
I <sub>OUT</sub>	Output Current	50	mA	
P <sub>D</sub>	Power Dissipation	1	W	
T <sub>A</sub>	Commercial Operation Temperature	0 to +70	°C	
	Industrial Operating Temperature	-40 to +85	°C	
T <sub>STG</sub>	Storage Temperature	-55 to +125	°C	

**Note:**

1. Stress greater than those listed under ABSOLUTE MAXIMUM RATINGS may cause permanent damage to the device. This is a stress rating only and functional operation of the device at these or any other conditions above those indicated in the operational sections of this specification is not implied. Exposure to absolute maximum rating conditions for extended periods may affect reliability.

**RECOMMENDED OPERATING CONDITIONS** (Voltages are referenced to GND.)

Symbol	Parameter	Min.	Typ.	Max.	Unit	
V <sub>CC</sub>	Supply Voltage	5V	4.5	5.0	5.5	V
		3.3V	3.0	3.3	3.6	
V <sub>IH</sub>	Input High Voltage	5V	2.4	—	V <sub>CC</sub> + 1.0	V
		3.3V	2.0	—	V <sub>CC</sub> + 0.3	
V <sub>IL</sub>	Input Low Voltage	5V	-1.0	—	0.8	V
		3.3V	-0.3	—	0.8	
T <sub>A</sub>	Commercial Ambient Temperature	0	—	70	°C	
	Industrial Ambient Temperature	-40	—	85	°C	

**CAPACITANCE<sup>(1,2)</sup>**

Symbol	Parameter	Max.	Unit
C <sub>IN1</sub>	Input Capacitance: A0-A9	5	pF
C <sub>IN2</sub>	Input Capacitance: $\overline{RAS}$ , $\overline{UCAS}$ , $\overline{LCAS}$ , $\overline{WE}$ , $\overline{OE}$	7	pF
C <sub>IO</sub>	Data Input/Output Capacitance: I/O0-I/O15	7	pF

**Notes:**

1. Tested initially and after any design or process changes that may affect these parameters.
2. Test conditions: T<sub>A</sub> = 25°C, f = 1 MHz.

**ELECTRICAL CHARACTERISTICS<sup>(1)</sup>**

(Recommended Operating Conditions unless otherwise noted.)

Symbol	Parameter	Test Condition	Speed	Min.	Max.	Unit
I <sub>IL</sub>	Input Leakage Current	Any input 0V ≤ V <sub>IN</sub> ≤ V <sub>CC</sub> Other inputs not under test = 0V		-5	5	μA
I <sub>IO</sub>	Output Leakage Current	Output is disabled (Hi-Z) 0V ≤ V <sub>OUT</sub> ≤ V <sub>CC</sub>		-5	5	μA
V <sub>OH</sub>	Output High Voltage Level	I <sub>OH</sub> = -5.0 mA (5V) I <sub>OH</sub> = -2.0 mA (3.3V)		2.4	—	V
V <sub>OL</sub>	Output Low Voltage Level	I <sub>OL</sub> = 4.2 mA (5V) I <sub>OL</sub> = 2.0 mA (3.3V)		—	0.4	V
I <sub>CC1</sub>	Standby Current: TTL	$\overline{RAS}, \overline{LCAS}, \overline{UCAS} \geq V_{IH}$ Commercial Industrial	5V 3.3V 5V 3.3V	— — — —	3 3 4 4	mA mA
I <sub>CC2</sub>	Standby Current: CMOS	$\overline{RAS}, \overline{LCAS}, \overline{UCAS} \geq V_{CC} - 0.2V$	5V 3.3V	— —	2 2	mA
I <sub>CC3</sub>	Operating Current: Random Read/Write <sup>(2,3,4)</sup> Average Power Supply Current	$\overline{RAS}, \overline{LCAS}, \overline{UCAS}$ , Address Cycling, t <sub>RC</sub> = t <sub>RC</sub> (min.)	-5V -6V	— —	160 145	mA
I <sub>CC4</sub>	Operating Current: EDO Page Mode <sup>(2,3,4)</sup> Average Power Supply Current	$\overline{RAS} = V_{IL}, \overline{LCAS}, \overline{UCAS}$ , Cycling t <sub>PC</sub> = t <sub>PC</sub> (min.)	-5V -6V	— —	90 80	mA
I <sub>CC5</sub>	Refresh Current: $\overline{RAS}$ -Only <sup>(2,3)</sup> Average Power Supply Current	$\overline{RAS}$ Cycling, $\overline{LCAS}, \overline{UCAS} \geq V_{IH}$ t <sub>RC</sub> = t <sub>RC</sub> (min.)	-5V -6V	— —	160 145	mA
I <sub>CC6</sub>	Refresh Current: CBR <sup>(2,3,5)</sup> Average Power Supply Current	$\overline{RAS}, \overline{LCAS}, \overline{UCAS}$ Cycling t <sub>RC</sub> = t <sub>RC</sub> (min.)	-5V -6V	— —	160 145	mA

**Notes:**

1. An initial pause of 200 μs is required after power-up followed by eight  $\overline{RAS}$  refresh cycles ( $\overline{RAS}$ -Only or CBR) before proper device operation is assured. The eight  $\overline{RAS}$  cycles wake-up should be repeated any time the t<sub>REF</sub> refresh requirement is exceeded.
2. Dependent on cycle rates.
3. Specified values are obtained with minimum cycle time and the output open.
4. Column-address is changed once each EDO page cycle.
5. Enables on-chip refresh and address counters.

**AC CHARACTERISTICS**<sup>(1,2,3,4,5,6)</sup>

(Recommended Operating Conditions unless otherwise noted.)

Symbol	Parameter	-50		-60		Units
		Min.	Max.	Min.	Max.	
t <sub>RC</sub>	Random READ or WRITE Cycle Time	84	—	104	—	ns
t <sub>RAC</sub>	Access Time from $\overline{\text{RAS}}$ <sup>(6, 7)</sup>	—	50	—	60	ns
t <sub>CAC</sub>	Access Time from $\overline{\text{CAS}}$ <sup>(6, 8, 15)</sup>	—	13	—	15	ns
t <sub>AA</sub>	Access Time from Column-Address <sup>(6)</sup>	—	25	—	30	ns
t <sub>RAS</sub>	$\overline{\text{RAS}}$ Pulse Width	50	10K	60	10K	ns
t <sub>RP</sub>	$\overline{\text{RAS}}$ Precharge Time	30	—	40	—	ns
t <sub>CAS</sub>	$\overline{\text{CAS}}$ Pulse Width <sup>(26)</sup>	8	10K	10	10K	ns
t <sub>CP</sub>	$\overline{\text{CAS}}$ Precharge Time <sup>(9, 25)</sup>	9	—	9	—	ns
t <sub>CSH</sub>	$\overline{\text{CAS}}$ Hold Time <sup>(21)</sup>	38	—	40	—	ns
t <sub>RCD</sub>	$\overline{\text{RAS}}$ to $\overline{\text{CAS}}$ Delay Time <sup>(10, 20)</sup>	12	37	14	45	ns
t <sub>ASR</sub>	Row-Address Setup Time	0	—	0	—	ns
t <sub>RAH</sub>	Row-Address Hold Time	8	—	10	—	ns
t <sub>ASC</sub>	Column-Address Setup Time <sup>(20)</sup>	0	—	0	—	ns
t <sub>CAH</sub>	Column-Address Hold Time <sup>(20)</sup>	8	—	10	—	ns
t <sub>AR</sub>	Column-Address Hold Time (referenced to $\overline{\text{RAS}}$ )	30	—	40	—	ns
t <sub>RAD</sub>	$\overline{\text{RAS}}$ to Column-Address Delay Time <sup>(11)</sup>	10	25	12	30	ns
t <sub>RAL</sub>	Column-Address to $\overline{\text{RAS}}$ Lead Time	25	—	30	—	ns
t <sub>RPC</sub>	$\overline{\text{RAS}}$ to $\overline{\text{CAS}}$ Precharge Time	5	—	5	—	ns
t <sub>RSH</sub>	$\overline{\text{RAS}}$ Hold Time <sup>(27)</sup>	8	—	10	—	ns
t <sub>RHCP</sub>	$\overline{\text{RAS}}$ Hold Time from $\overline{\text{CAS}}$ Precharge	37	—	37	—	ns
t <sub>CLZ</sub>	$\overline{\text{CAS}}$ to Output in Low-Z <sup>(15, 29)</sup>	0	—	0	—	ns
t <sub>CRP</sub>	$\overline{\text{CAS}}$ to $\overline{\text{RAS}}$ Precharge Time <sup>(21)</sup>	5	—	5	—	ns
t <sub>OD</sub>	Output Disable Time <sup>(19, 28, 29)</sup>	3	15	3	15	ns
t <sub>OE</sub>	Output Enable Time <sup>(15, 16)</sup>	—	13	—	15	ns
t <sub>OED</sub>	Output Enable Data Delay (Write)	20	—	20	—	ns
t <sub>OEHC</sub>	$\overline{\text{OE}}$ HIGH Hold Time from $\overline{\text{CAS}}$ HIGH	5	—	5	—	ns
t <sub>OEP</sub>	$\overline{\text{OE}}$ HIGH Pulse Width	10	—	10	—	ns
t <sub>OES</sub>	$\overline{\text{OE}}$ LOW to $\overline{\text{CAS}}$ HIGH Setup Time	5	—	5	—	ns
t <sub>RCS</sub>	Read Command Setup Time <sup>(17, 20)</sup>	0	—	0	—	ns
t <sub>RRH</sub>	Read Command Hold Time (referenced to $\overline{\text{RAS}}$ ) <sup>(12)</sup>	0	—	0	—	ns
t <sub>RCH</sub>	Read Command Hold Time (referenced to $\overline{\text{CAS}}$ ) <sup>(12, 17, 21)</sup>	0	—	0	—	ns
t <sub>WCH</sub>	Write Command Hold Time <sup>(17, 27)</sup>	8	—	10	—	ns
t <sub>WCR</sub>	Write Command Hold Time (referenced to $\overline{\text{RAS}}$ ) <sup>(17)</sup>	40	—	50	—	ns

**AC CHARACTERISTICS (Continued)**<sup>(1,2,3,4,5,6)</sup>

(Recommended Operating Conditions unless otherwise noted.)

Symbol	Parameter	-50		-60		Units
		Min.	Max.	Min.	Max.	
tWP	Write Command Pulse Width <sup>(17)</sup>	8	—	10	—	ns
tWPZ	$\overline{WE}$ Pulse Widths to Disable Outputs	10	—	10	—	ns
trWL	Write Command to $\overline{RAS}$ Lead Time <sup>(17)</sup>	13	—	15	—	ns
tcWL	Write Command to $\overline{CAS}$ Lead Time <sup>(17, 21)</sup>	8	—	10	—	ns
twCS	Write Command Setup Time <sup>(14, 17, 20)</sup>	0	—	0	—	ns
tdHR	Data-in Hold Time (referenced to $\overline{RAS}$ )	39	—	39	—	ns
tACH	Column-Address Setup Time to $\overline{CAS}$ Precharge during WRITE Cycle	15	—	15	—	ns
toEH	$\overline{OE}$ Hold Time from $\overline{WE}$ during READ-MODIFY-WRITE cycle <sup>(18)</sup>	8	—	10	—	ns
tdS	Data-In Setup Time <sup>(15, 22)</sup>	0	—	0	—	ns
tdH	Data-In Hold Time <sup>(15, 22)</sup>	8	—	10	—	ns
trWC	READ-MODIFY-WRITE Cycle Time	108	—	133	—	ns
trWD	$\overline{RAS}$ to $\overline{WE}$ Delay Time during READ-MODIFY-WRITE Cycle <sup>(14)</sup>	64	—	77	—	ns
tcWD	$\overline{CAS}$ to $\overline{WE}$ Delay Time <sup>(14, 20)</sup>	26	—	32	—	ns
tAWD	Column-Address to $\overline{WE}$ Delay Time <sup>(14)</sup>	39	—	47	—	ns
tPC	EDO Page Mode READ or WRITE Cycle Time <sup>(24)</sup>	20	—	25	—	ns
trASP	$\overline{RAS}$ Pulse Width in EDO Page Mode	50	100K	60	100K	ns
tcPA	Access Time from $\overline{CAS}$ Precharge <sup>(15)</sup>	—	30	—	35	ns
tPRWC	EDO Page Mode READ-WRITE Cycle Time <sup>(24)</sup>	56	—	68	—	ns
tCOH	Data Output Hold after $\overline{CAS}$ LOW	5	—	5	—	ns
toFF	Output Buffer Turn-Off Delay from $\overline{CAS}$ or $\overline{RAS}$ <sup>(13,15,19, 29)</sup>	1.6	12	1.6	15	ns
tWHZ	Output Disable Delay from $\overline{WE}$	3	10	3	10	ns
tCLCH	Last $\overline{CAS}$ going LOW to First $\overline{CAS}$ returning HIGH <sup>(23)</sup>	10	—	10	—	ns
tCSR	$\overline{CAS}$ Setup Time (CBR REFRESH) <sup>(30, 20)</sup>	5	—	5	—	ns
tCHR	$\overline{CAS}$ Hold Time (CBR REFRESH) <sup>(30, 21)</sup>	8	—	10	—	ns
tORD	$\overline{OE}$ Setup Time prior to $\overline{RAS}$ during HIDDEN REFRESH Cycle	0	—	0	—	ns
tREF	Auto Refresh Period (1,024 Cycles)	—	16	—	16	ms
tREF	Self Refresh Period (1,024 Cycles)	—	128	—	128	ms
tr	Transition Time (Rise or Fall) <sup>(2, 3)</sup>	1	50	1	50	ns



## AC TEST CONDITIONS

Output load: Two TTL Loads and 50 pF ( $V_{CC} = 5.0V \pm 10\%$ )  
One TTL Load and 50 pF ( $V_{CC} = 3.3V \pm 10\%$ )

Input timing reference levels:  $V_{IH} = 2.4V$ ,  $V_{IL} = 0.8V$  ( $V_{CC} = 5.0V \pm 10\%$ );  
 $V_{IH} = 2.0V$ ,  $V_{IL} = 0.8V$  ( $V_{CC} = 3.3V \pm 10\%$ )

Output timing reference levels:  $V_{OH} = 2.0V$ ,  $V_{OL} = 0.8V$  ( $V_{CC} = 5V \pm 10\%$ ,  $3.3V \pm 10\%$ )

### Notes:

1. An initial pause of 200  $\mu s$  is required after power-up followed by eight  $\overline{RAS}$  refresh cycle ( $\overline{RAS}$ -Only or CBR) before proper device operation is assured. The eight  $\overline{RAS}$  cycles wake-up should be repeated any time the  $t_{REF}$  refresh requirement is exceeded.
2.  $V_{IH}$  (MIN) and  $V_{IL}$  (MAX) are reference levels for measuring timing of input signals. Transition times, are measured between  $V_{IH}$  and  $V_{IL}$  (or between  $V_{IL}$  and  $V_{IH}$ ) and assume to be 1 ns for all inputs.
3. In addition to meeting the transition rate specification, all input signals must transit between  $V_{IH}$  and  $V_{IL}$  (or between  $V_{IL}$  and  $V_{IH}$ ) in a monotonic manner.
4. If  $\overline{CAS}$  and  $\overline{RAS} = V_{IH}$ , data output is High-Z.
5. If  $\overline{CAS} = V_{IL}$ , data output may contain data from the last valid READ cycle.
6. Measured with a load equivalent to one TTL gate and 50 pF.
7. Assumes that  $t_{RCD} = t_{RCD} (MAX)$ . If  $t_{RCD}$  is greater than the maximum recommended value shown in this table,  $t_{RAC}$  will increase by the amount that  $t_{RCD}$  exceeds the value shown.
8. Assumes that  $t_{RCD} \cdot t_{RCD} (MAX)$ .
9. If  $\overline{CAS}$  is LOW at the falling edge of  $\overline{RAS}$ , data out will be maintained from the previous cycle. To initiate a new cycle and clear the data output buffer,  $\overline{CAS}$  and  $\overline{RAS}$  must be pulsed for  $t_{CP}$ .
10. Operation with the  $t_{RCD} (MAX)$  limit ensures that  $t_{RAC} (MAX)$  can be met.  $t_{RCD} (MAX)$  is specified as a reference point only; if  $t_{RCD}$  is greater than the specified  $t_{RCD} (MAX)$  limit, access time is controlled exclusively by  $t_{CAC}$ .
11. Operation within the  $t_{RAD} (MAX)$  limit ensures that  $t_{RCD} (MAX)$  can be met.  $t_{RAD} (MAX)$  is specified as a reference point only; if  $t_{RAD}$  is greater than the specified  $t_{RAD} (MAX)$  limit, access time is controlled exclusively by  $t_{AA}$ .
12. Either  $t_{RCH}$  or  $t_{RRH}$  must be satisfied for a READ cycle.
13.  $t_{OFF} (MAX)$  defines the time at which the output achieves the open circuit condition; it is not a reference to  $V_{OH}$  or  $V_{OL}$ .
14.  $t_{WCS}$ ,  $t_{RWD}$ ,  $t_{AWD}$  and  $t_{CWD}$  are restrictive operating parameters in LATE WRITE and READ-MODIFY-WRITE cycle only. If  $t_{WCS} \cdot t_{WCS} (MIN)$ , the cycle is an EARLY WRITE cycle and the data output will remain open circuit throughout the entire cycle. If  $t_{RWD} \cdot t_{RWD} (MIN)$ ,  $t_{AWD} \cdot t_{AWD} (MIN)$  and  $t_{CWD} \cdot t_{CWD} (MIN)$ , the cycle is a READ-WRITE cycle and the data output will contain data read from the selected cell. If neither of the above conditions is met, the state of I/O (at access time and until  $\overline{CAS}$  and  $\overline{RAS}$  or  $\overline{OE}$  go back to  $V_{IH}$ ) is indeterminate.  $\overline{OE}$  held HIGH and  $\overline{WE}$  taken LOW after  $\overline{CAS}$  goes LOW result in a LATE WRITE ( $\overline{OE}$ -controlled) cycle.
15. Output parameter (I/O) is referenced to corresponding  $\overline{CAS}$  input, I/O0-I/O7 by  $\overline{LCAS}$  and I/O8-I/O15 by  $\overline{UCAS}$ .
16. During a READ cycle, if  $\overline{OE}$  is LOW then taken HIGH before  $\overline{CAS}$  goes HIGH, I/O goes open. If  $\overline{OE}$  is tied permanently LOW, a LATE WRITE or READ-MODIFY-WRITE is not possible.
17. Write command is defined as  $\overline{WE}$  going low.
18. LATE WRITE and READ-MODIFY-WRITE cycles must have both  $t_{OD}$  and  $t_{OEH}$  met ( $\overline{OE}$  HIGH during WRITE cycle) in order to ensure that the output buffers will be open during the WRITE cycle. The I/Os will provide the previously written data if  $\overline{CAS}$  remains LOW and  $\overline{OE}$  is taken back to LOW after  $t_{OEH}$  is met.
19. The I/Os are in open during READ cycles once  $t_{OD}$  or  $t_{OFF}$  occur.
20. The first  $\chi \overline{CAS}$  edge to transition LOW.
21. The last  $\chi \overline{CAS}$  edge to transition HIGH.
22. These parameters are referenced to  $\overline{CAS}$  leading edge in EARLY WRITE cycles and  $\overline{WE}$  leading edge in LATE WRITE or READ-MODIFY-WRITE cycles.
23. Last falling  $\chi \overline{CAS}$  edge to first rising  $\chi \overline{CAS}$  edge.
24. Last rising  $\chi \overline{CAS}$  edge to next cycle's last rising  $\chi \overline{CAS}$  edge.
25. Last rising  $\chi \overline{CAS}$  edge to first falling  $\chi \overline{CAS}$  edge.
26. Each  $\chi \overline{CAS}$  must meet minimum pulse width.
27. Last  $\chi \overline{CAS}$  to go LOW.
28. I/Os controlled, regardless  $\overline{UCAS}$  and  $\overline{LCAS}$ .
29. The 3 ns minimum is a parameter guaranteed by design.
30. Enables on-chip refresh and address counters.

READCYCLE

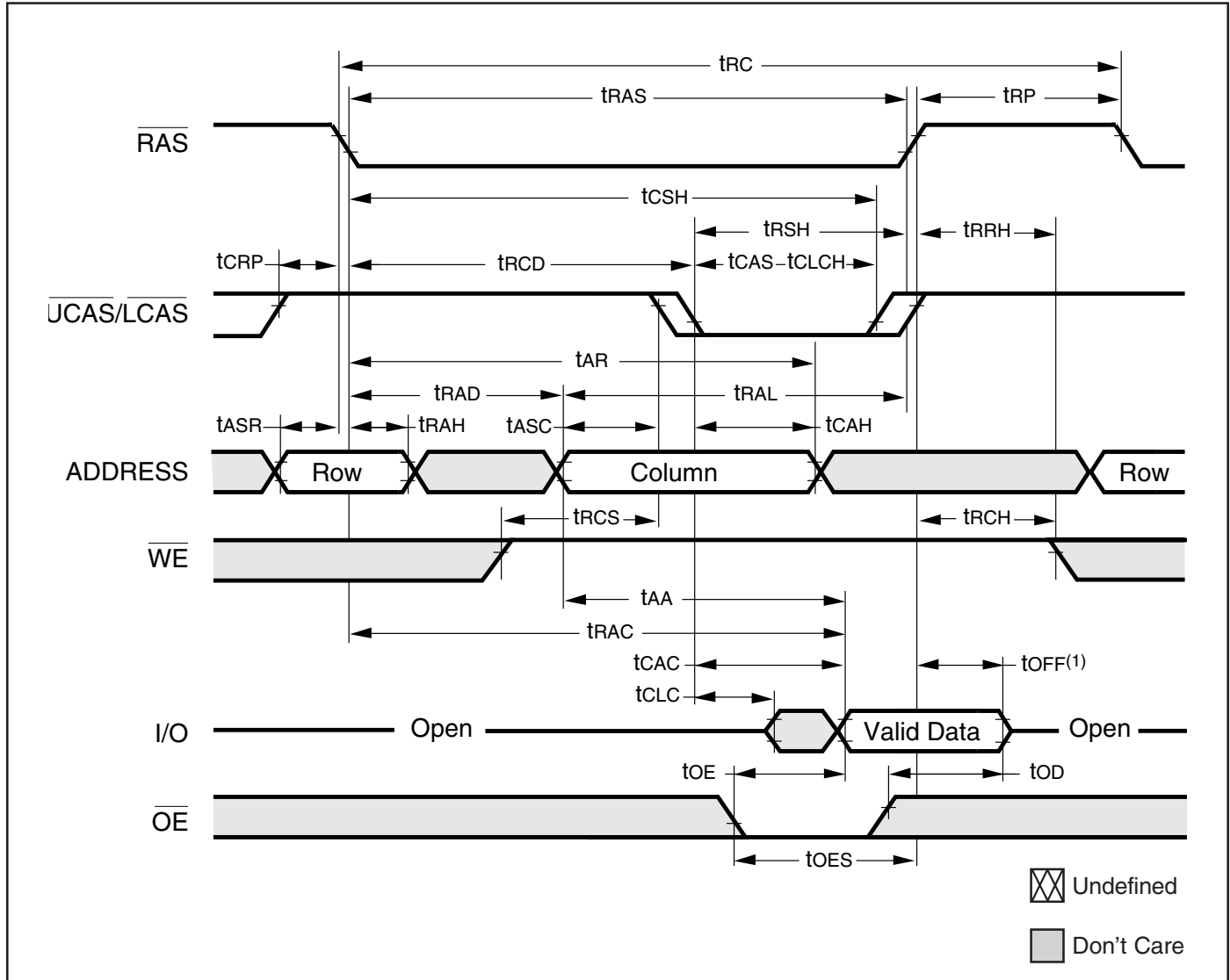

Note:

1.  $t_{\text{OFF}}$  is referenced from rising edge of  $\overline{\text{RAS}}$  or  $\overline{\text{CAS}}$ , whichever occurs last.

EARLY WRITE CYCLE ( $\overline{OE}$  = DON'T CARE)

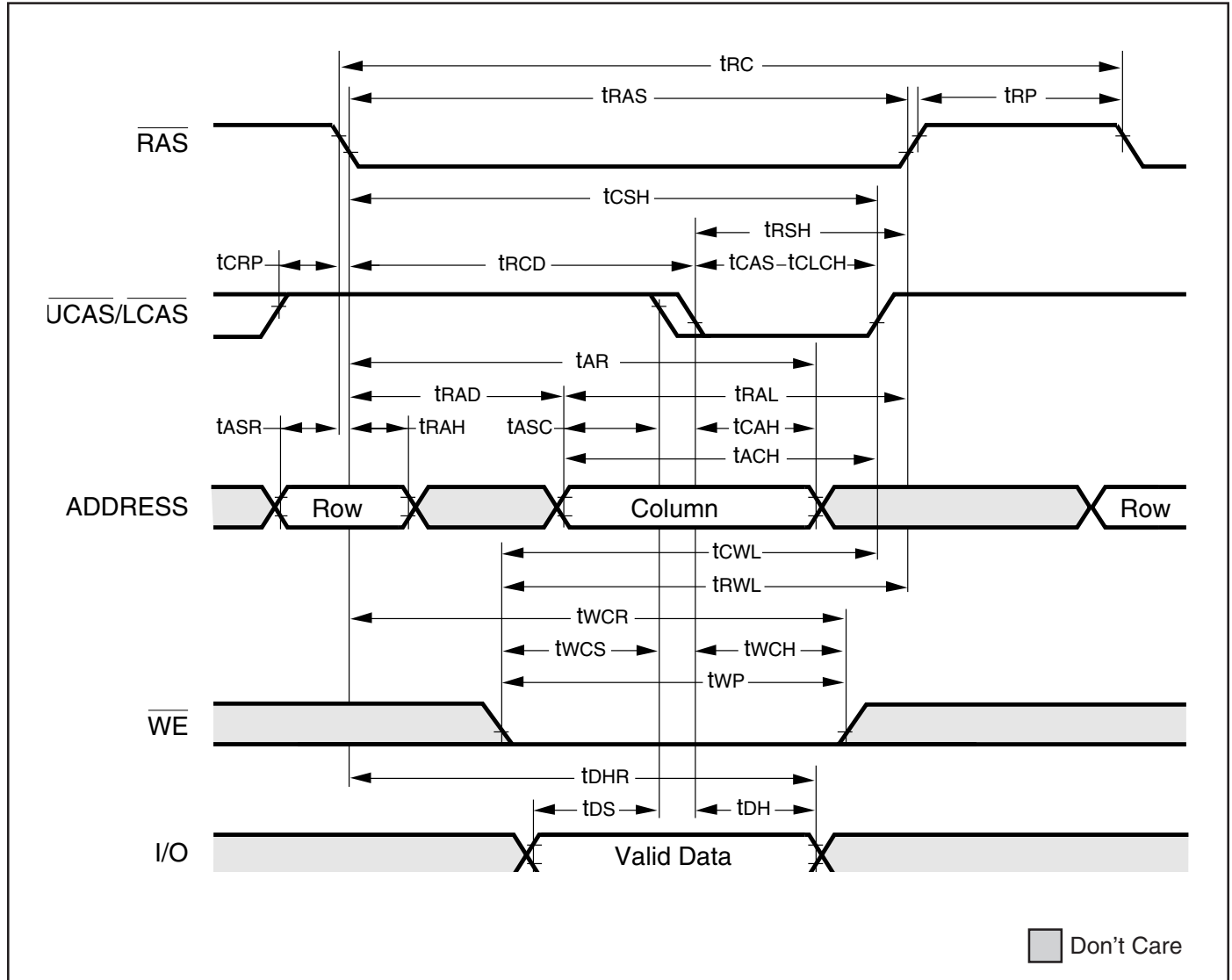

READ WRITE CYCLE (LATE WRITE and READ-MODIFY-WRITE Cycles)

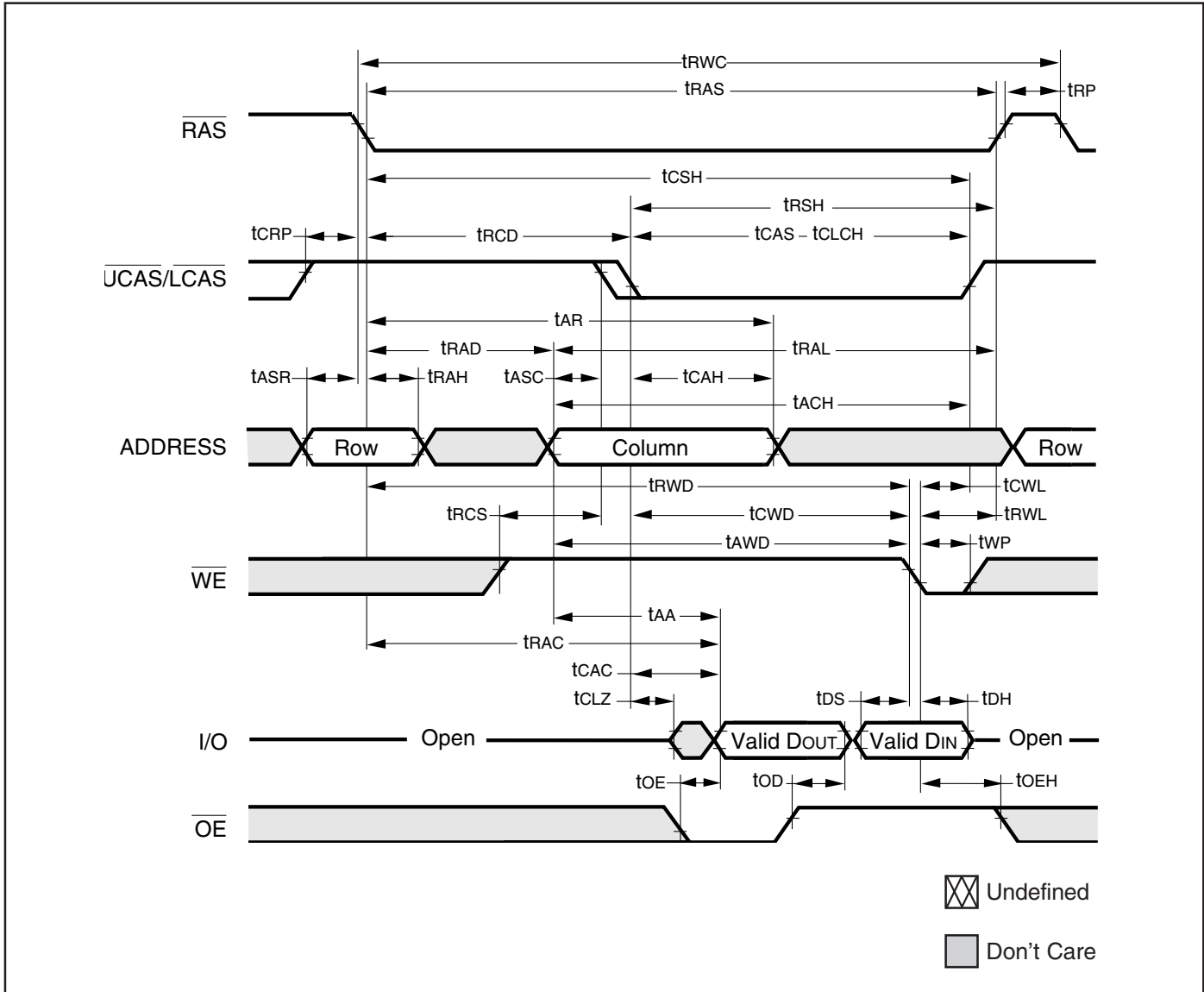

EDO-PAGE-MODE READ CYCLE

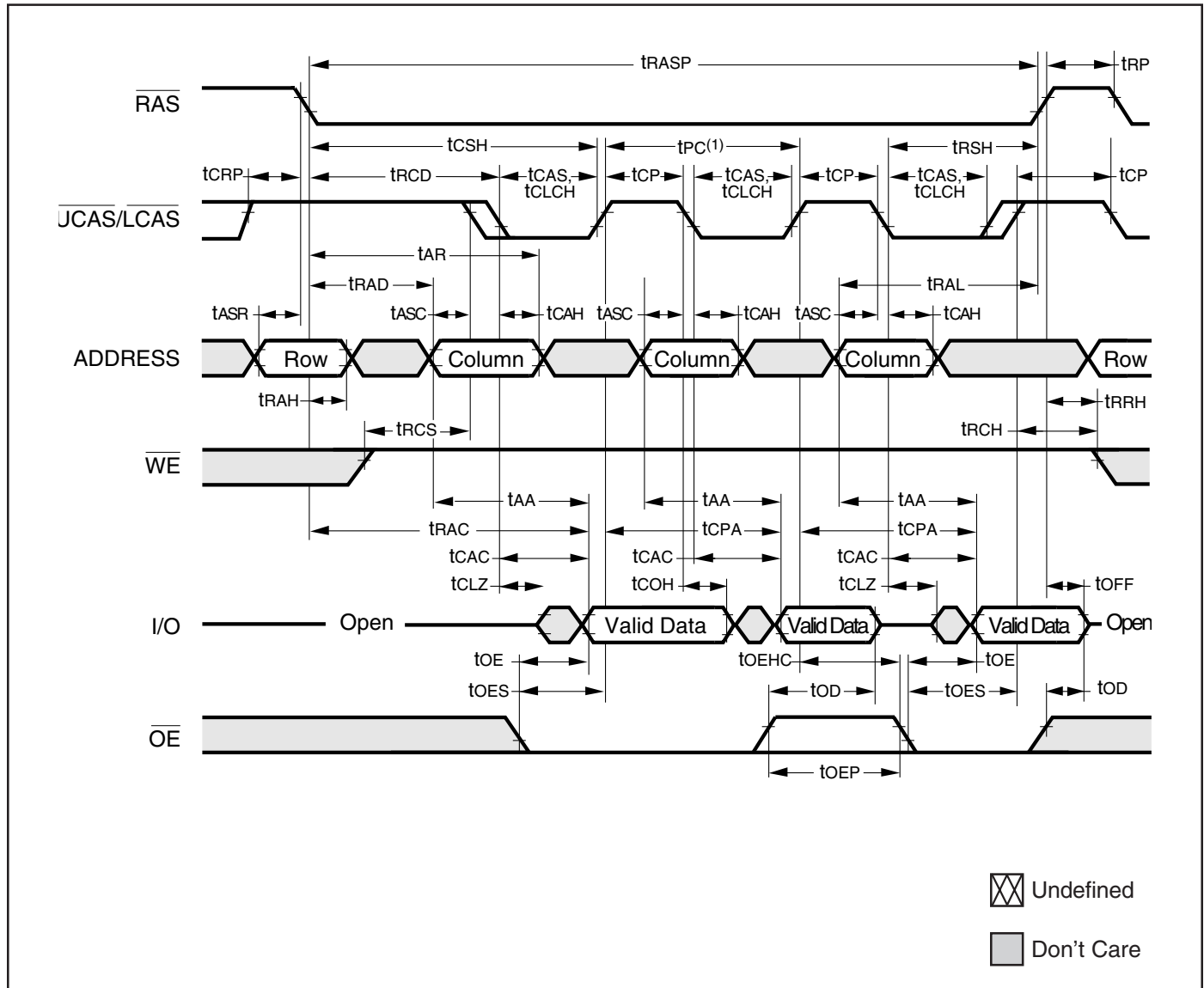

Note:

1. tpc can be measured from falling edge of  $\overline{\text{CAS}}$  to falling edge of  $\overline{\text{CAS}}$ , or from rising edge of  $\overline{\text{CAS}}$  to rising edge of  $\overline{\text{CAS}}$ . Both measurements must meet the tpc specifications.

EDO-PAGE-MODE EARLY-WRITE CYCLE

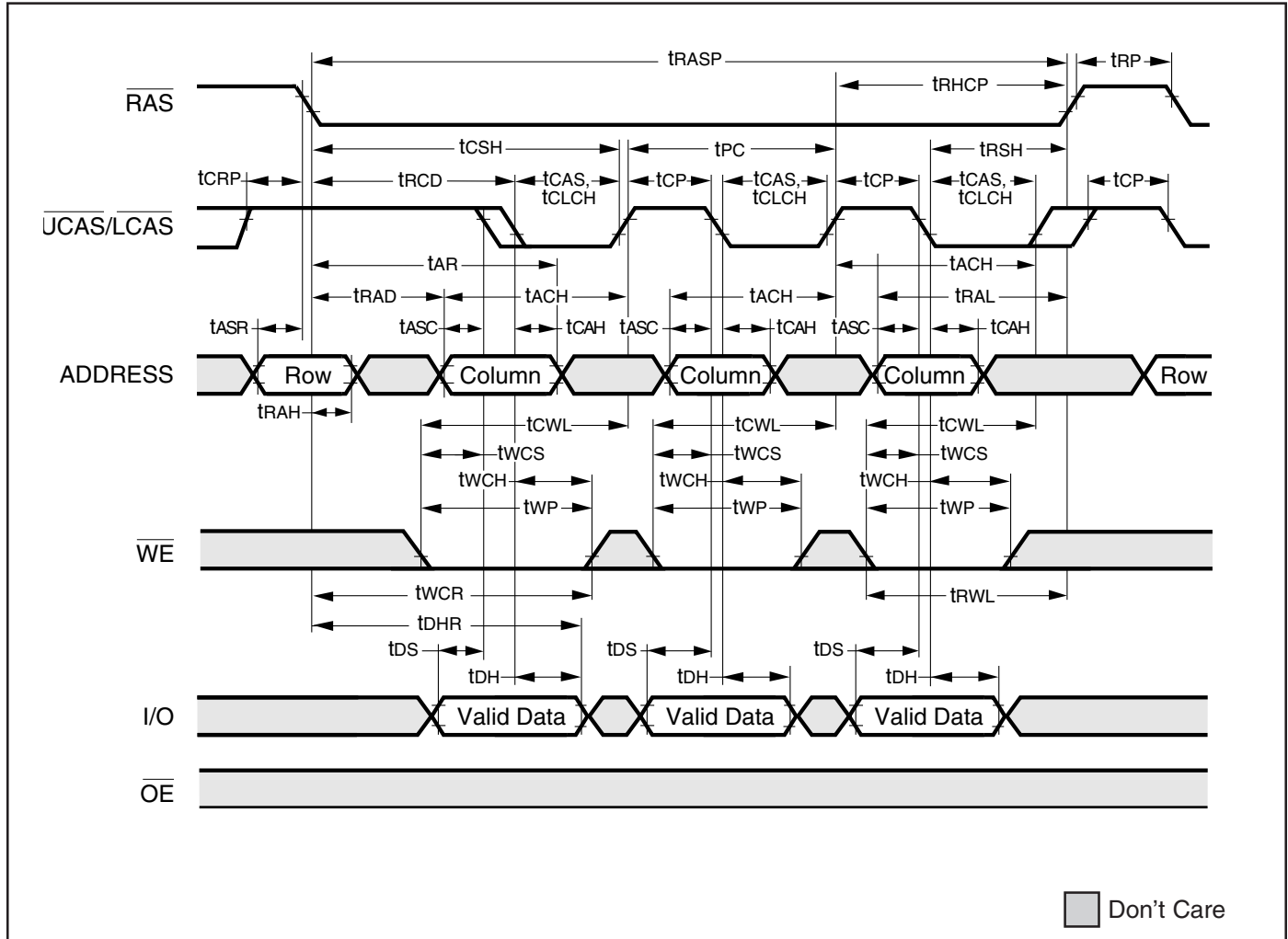

EDO-PAGE-MODE READ-WRITE CYCLE (LATE WRITE and READ-MODIFY WRITE Cycles)

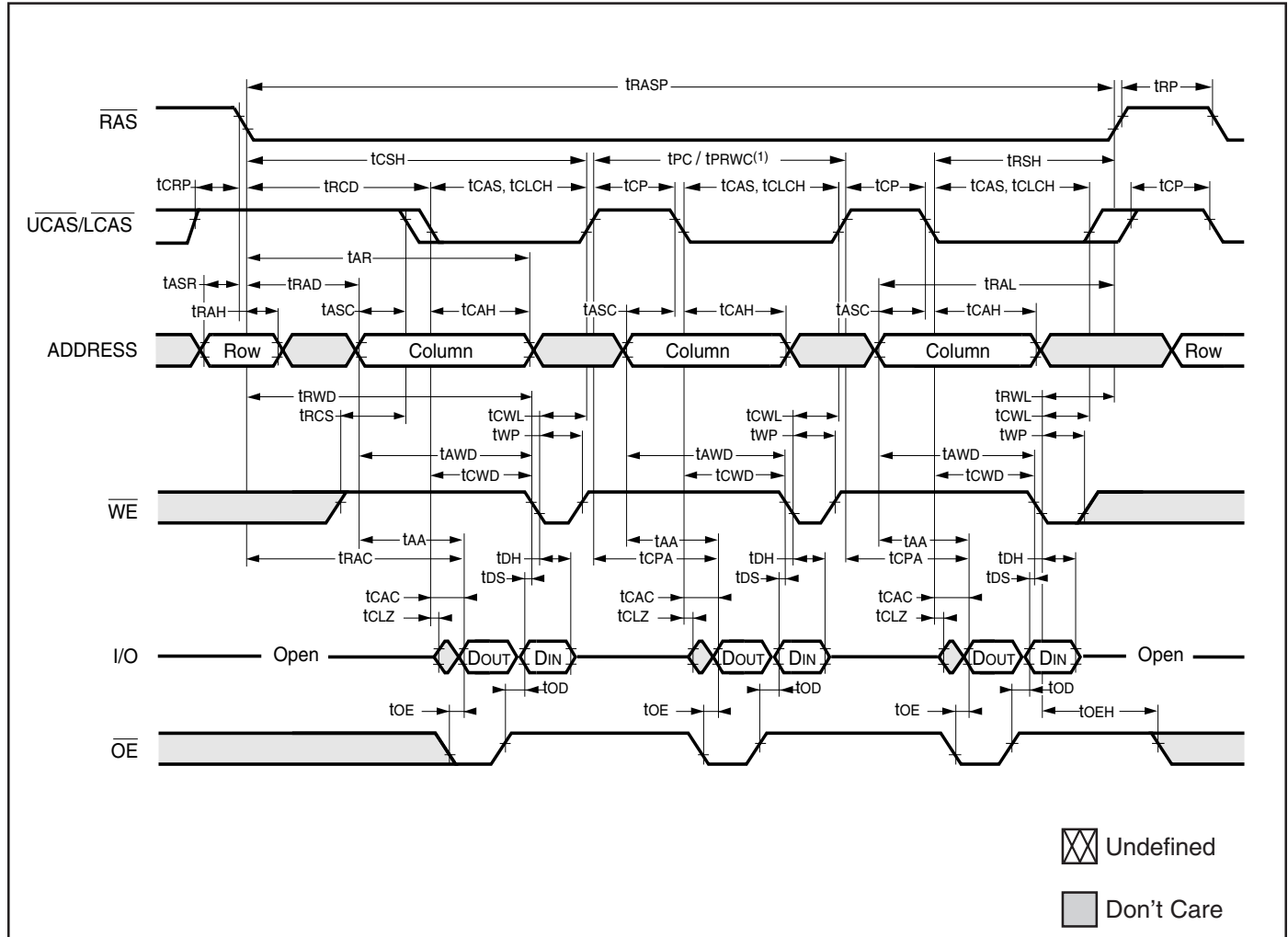

Note:

1.  $t_{PC}$  can be measured from falling edge of  $\overline{CAS}$  to falling edge of  $\overline{CAS}$ , or from rising edge of  $\overline{CAS}$  to rising edge of  $\overline{CAS}$ . Both measurements must meet the  $t_{PC}$  specifications.

EDO-PAGE-MODE READ-EARLY-WRITE CYCLE (Pseudo READ-MODIFY WRITE)

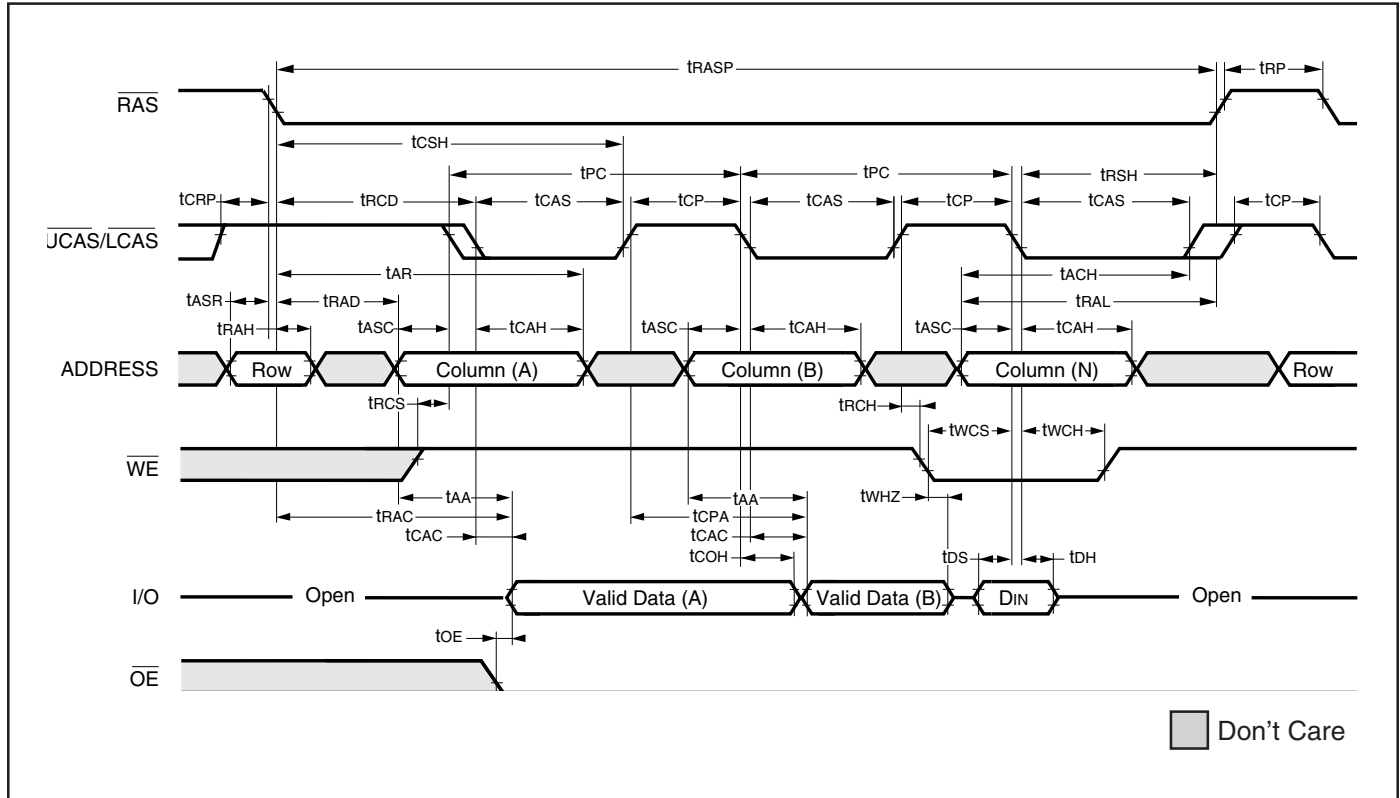



AC WAVEFORMS

READ CYCLE (With  $\overline{WE}$ -Controlled Disable)

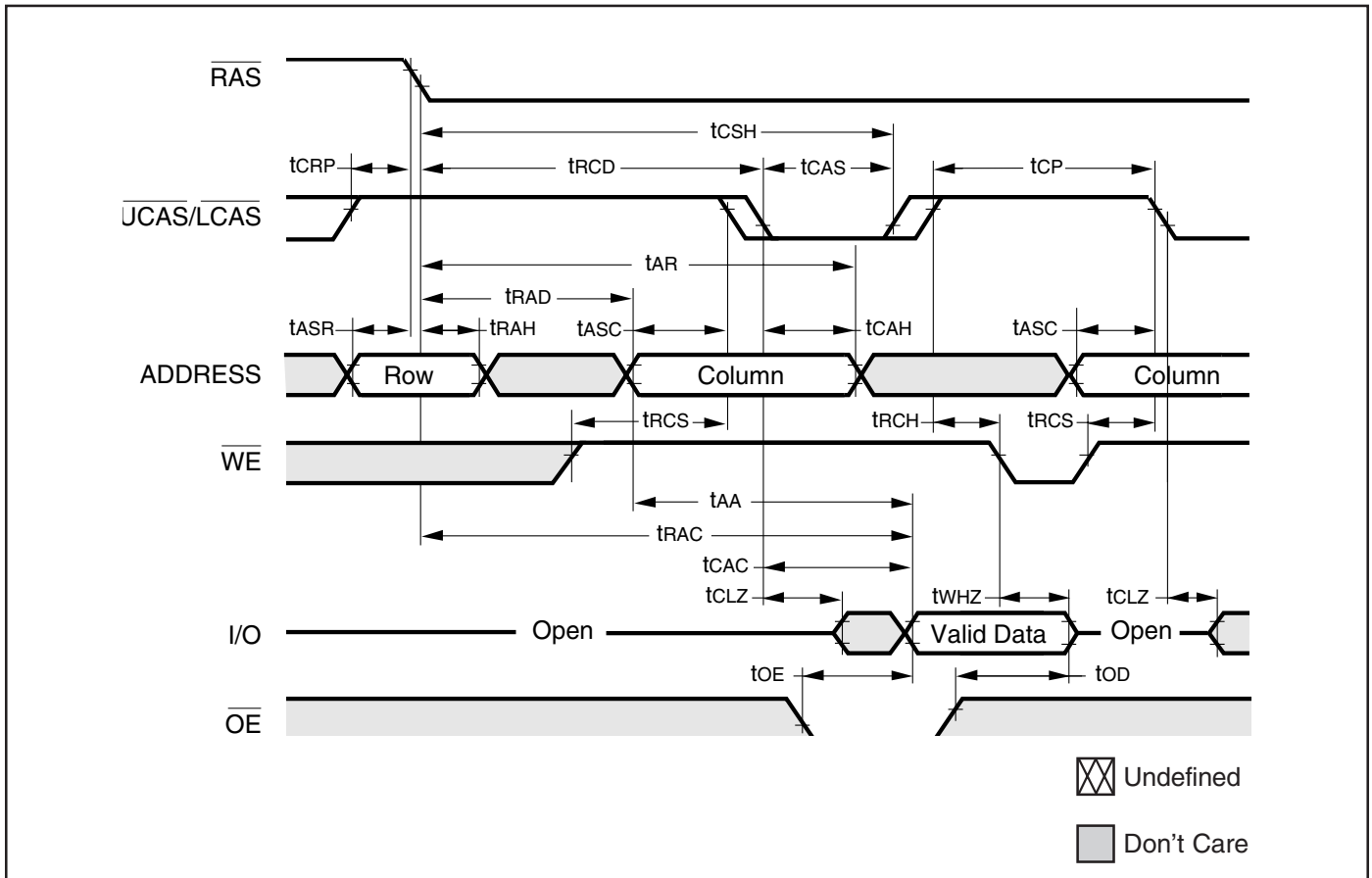

$\overline{RAS}$ -ONLY REFRESH CYCLE ( $\overline{OE}$ ,  $\overline{WE}$  = DON'T CARE)

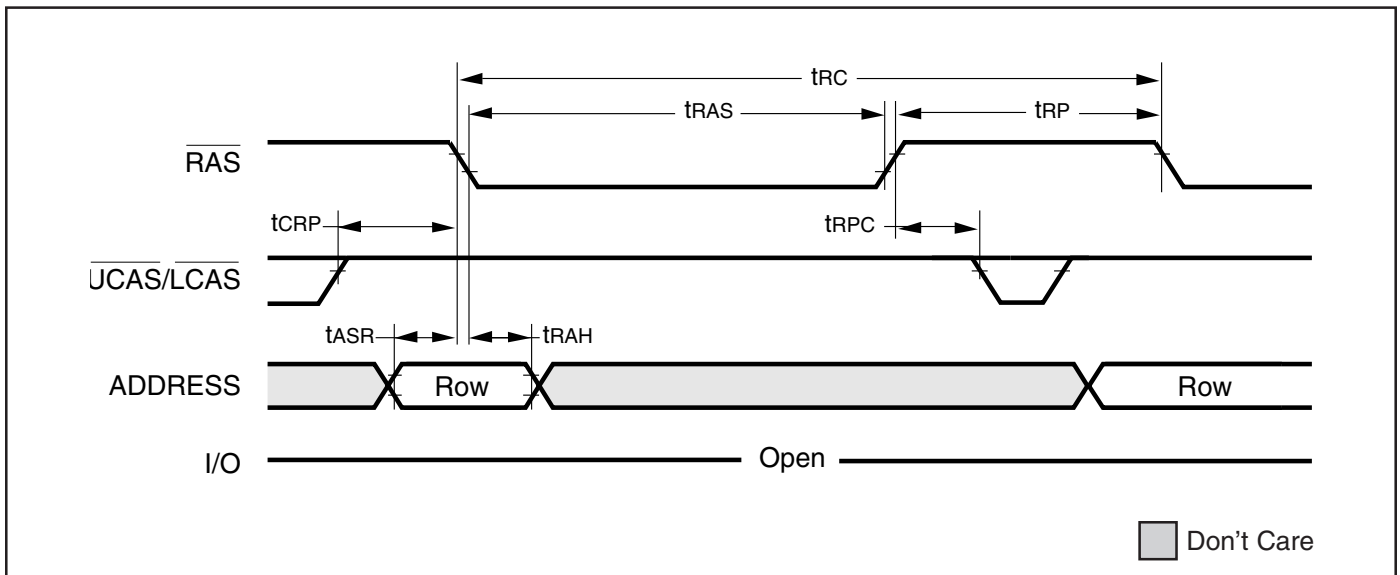

**$\overline{\text{CBR}}$  REFRESH CYCLE** (Addresses;  $\overline{\text{WE}}$ ,  $\overline{\text{OE}}$  = DON'T CARE)

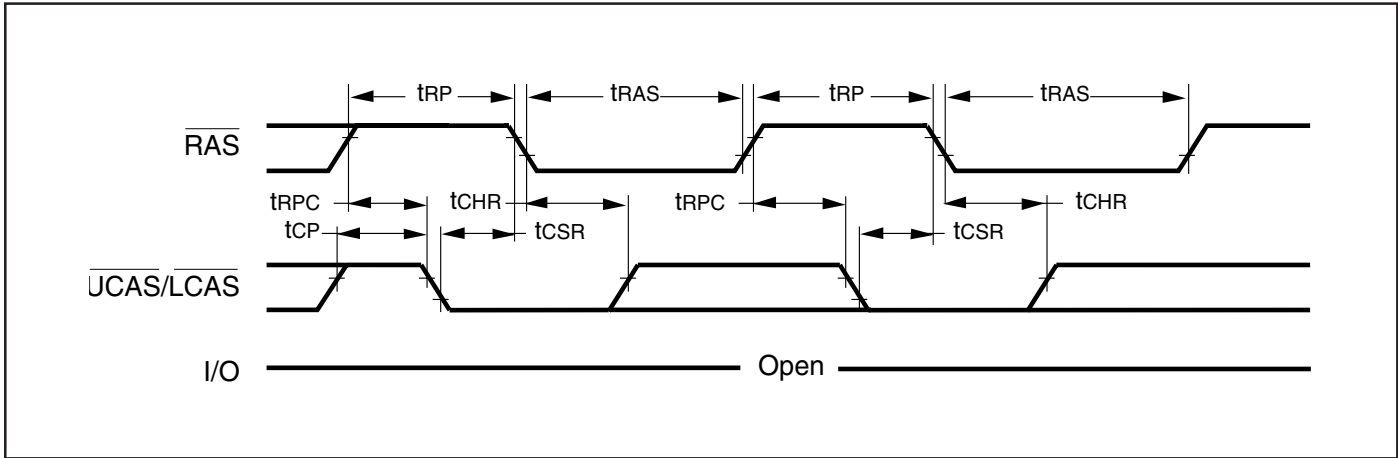

**HIDDEN REFRESH CYCLE<sup>(1)</sup>** ( $\overline{\text{WE}}$  = HIGH;  $\overline{\text{OE}}$  = LOW)

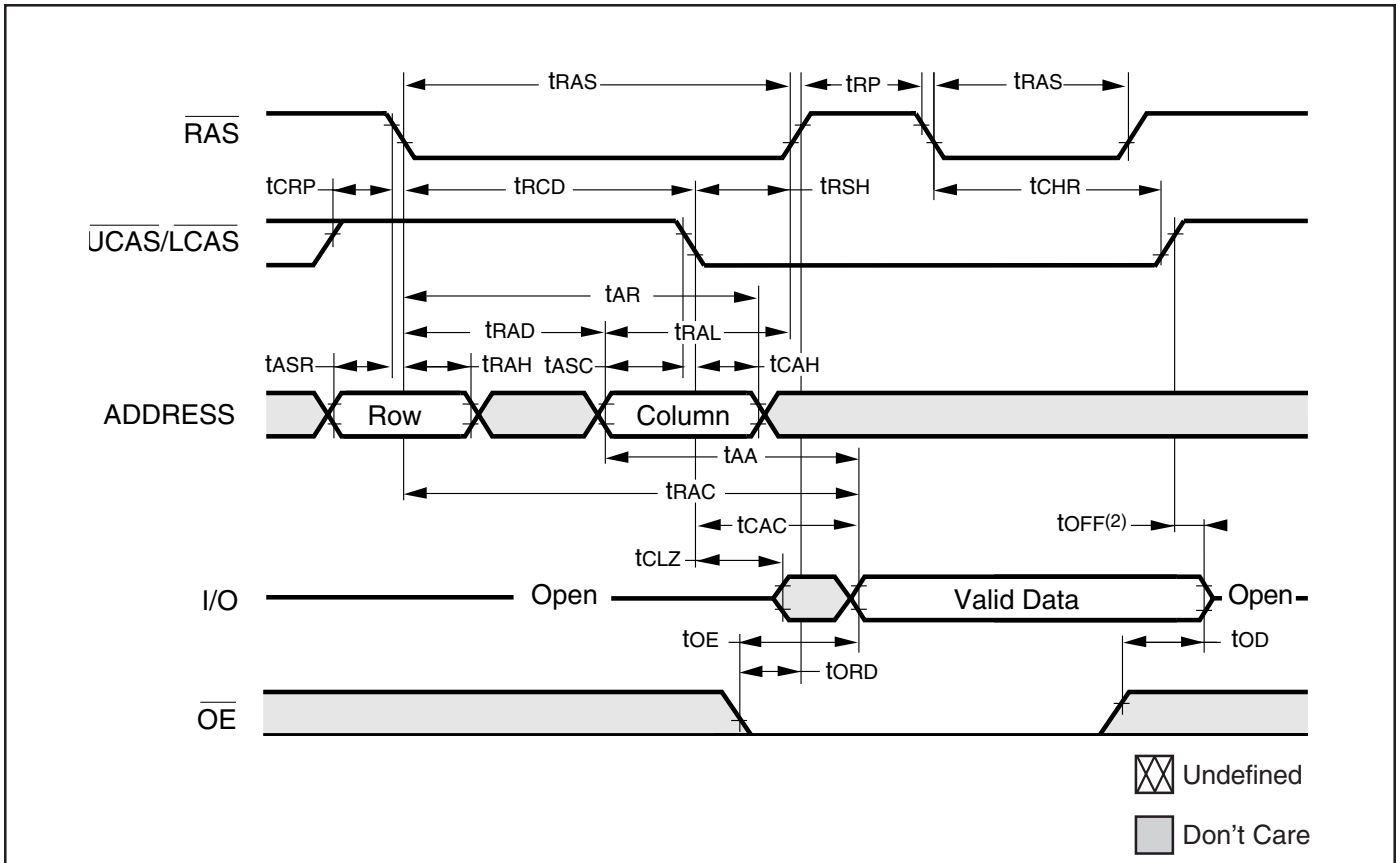

**Notes:**

1. A Hidden Refresh may also be performed after a Write Cycle. In this case,  $\overline{\text{WE}}$  = LOW and  $\overline{\text{OE}}$  = HIGH.
2.  $t_{OFF}$  is referenced from rising edge of  $\overline{\text{RAS}}$  or  $\overline{\text{CAS}}$ , whichever occurs last.

**ORDERING INFORMATION : 5V**

**Commercial Range: 0°C to 70°C**

Speed (ns)	Order Part No.	Package
50	IS41C16100-50K	400-mil SOJ
	IS41C16100-50KL	400-mil SOJ, Lead-free
	IS41C16100-50T	400-mil TSOP (Type II)
	IS41C16100-50TL	400-mil TSOP (Type II), Lead-free
60	IS41C16100-60K	400-mil SOJ
	IS41C16100-60KL	400-mil SOJ, Lead-free
	IS41C16100-60T	400-mil TSOP (Type II)
	IS41C16100-60TL	400-mil TSOP (Type II), Lead-free

**Industrial Range: -40°C to 85°C**

Speed (ns)	Order Part No.	Package
50	IS41C16100-50KI	400-mil SOJ
	IS41C16100-50KLI	400-mil SOJ, Lead-free
	IS41C16100-50TI	400-mil TSOP (Type II)
	IS41C16100-50TLI	400-mil TSOP (Type II), Lead-free
60	IS41C16100-60KI	400-mil SOJ
	IS41C16100-60KLI	400-mil SOJ, Lead-free
	IS41C16100-60TI	400-mil TSOP (Type II)
	IS41C16100-60TLI	400-mil TSOP (Type II), Lead-free

**ORDERING INFORMATION : 3.3V**

**Commercial Range: 0°C to 70°C**

Speed (ns)	Order Part No.	Package
50	IS41LV16100-50K	400-mil SOJ
	IS41LV16100-50T	400-mil TSOP (Type II)
	IS41LV16100-50TL	400-mil TSOP (Type II), Lead-free
60	IS41LV16100-60K	400-mil SOJ
	IS41LV16100-60T	400-mil TSOP (Type II)
	IS41LV16100-60TL	400-mil TSOP (Type II), Lead-free

**Industrial Range: -40°C to 85°C**

Speed (ns)	Order Part No.	Package
50	IS41LV16100-50KI	400-mil SOJ
	IS41LV16100-50TI	400-mil TSOP (Type II)
	IS41LV16100-50TLI	400-mil TSOP (Type II), Lead-free
60	IS41LV16100-60KI	400-mil SOJ
	IS41LV16100-60TI	400-mil TSOP (Type II)
	IS41LV16100-60TLI	400-mil TSOP (Type II), Lead-free

# PACKAGING INFORMATION

400-mil Plastic SOJ

Package Code: K



**Notes:**

1. Controlling dimension: millimeters.
2. BSC = Basic lead spacing between centers.
3. Dimensions D and E1 do not include mold flash protrusions and should be measured from the bottom of the package.
4. Reference document: JEDEC MS-027.

Symbol	Millimeters		Inches		Millimeters		Inches		Millimeters		Inches	
	Min	Max	Min	Max	Min	Max	Min	Max	Min	Max	Min	Max
No. Leads (N)	28				32				36			
A	3.25	3.75	0.128	0.148	3.25	3.75	0.128	0.148	3.25	3.75	0.128	0.148
A1	0.64	—	0.025	—	0.64	—	0.025	—	0.64	—	0.025	—
A2	2.08	—	0.082	—	2.08	—	0.082	—	2.08	—	0.082	—
B	0.38	0.51	0.015	0.020	0.38	0.51	0.015	0.020	0.38	0.51	0.015	0.020
b	0.66	0.81	0.026	0.032	0.66	0.81	0.026	0.032	0.66	0.81	0.026	0.032
C	0.18	0.33	0.007	0.013	0.18	0.33	0.007	0.013	0.18	0.33	0.007	0.013
D	18.29	18.54	0.720	0.730	20.82	21.08	0.820	0.830	23.37	23.62	0.920	0.930
E	11.05	11.30	0.435	0.445	11.05	11.30	0.435	0.445	11.05	11.30	0.435	0.445
E1	10.03	10.29	0.395	0.405	10.03	10.29	0.395	0.405	10.03	10.29	0.395	0.405
E2	9.40 BSC		0.370 BSC		9.40 BSC		0.370 BSC		9.40 BSC		0.370 BSC	
e	1.27 BSC		0.050 BSC		1.27 BSC		0.050 BSC		1.27 BSC		0.050 BSC	

Copyright © 2003 Integrated Silicon Solution, Inc. All rights reserved. ISSI reserves the right to make changes to this specification and its products at any time without notice. ISSI assumes no liability arising out of the application or use of any information, products or services described herein. Customers are advised to obtain the latest version of this device specification before relying on any published information and before placing orders for products.

**Integrated Silicon Solution, Inc. — [www.issi.com](http://www.issi.com) — 1-800-379-4774**

Rev. F  
10/29/03

Symbol	Millimeters		Inches		Millimeters		Inches		Millimeters		Inches	
	Min	Max	Min	Max	Min	Max	Min	Max	Min	Max	Min	Max
No. Leads (N)	<b>40</b>				<b>42</b>				<b>44</b>			
A	3.25	3.75	0.128	0.148	3.25	3.75	0.128	0.148	3.25	3.75	0.128	0.148
A1	0.64	—	0.025	—	0.64	—	0.025	—	0.64	—	0.025	—
A2	2.08	—	0.082	—	2.08	—	0.082	—	2.08	—	0.082	—
B	0.38	0.51	0.015	0.020	0.38	0.51	0.015	0.020	0.38	0.51	0.015	0.020
b	0.66	0.81	0.026	0.032	0.66	0.81	0.026	0.032	0.66	0.81	0.026	0.032
C	0.18	0.33	0.007	0.013	0.18	0.33	0.007	0.013	0.18	0.33	0.007	0.013
D	25.91	26.16	1.020	1.030	27.18	27.43	1.070	1.080	28.45	28.70	1.120	1.130
E	11.05	11.30	0.435	0.445	11.05	11.30	0.435	0.445	11.05	11.30	0.435	0.445
E1	10.03	10.29	0.395	0.405	10.03	10.29	0.395	0.405	10.03	10.29	0.395	0.405
E2	9.40 BSC		0.370 BSC		9.40 BSC		0.370 BSC		9.40 BSC		0.370 BSC	
e	1.27 BSC		0.050 BSC		1.27 BSC		0.050 BSC		1.27 BSC		0.050 BSC	

Copyright © 2003 Integrated Silicon Solution, Inc. All rights reserved. ISSI reserves the right to make changes to this specification and its products at any time without notice. ISSI assumes no liability arising out of the application or use of any information, products or services described herein. Customers are advised to obtain the latest version of this device specification before relying on any published information and before placing orders for products.

# PACKAGING INFORMATION

## Plastic TSOP Package Code: T (Type II)



### Notes:

1. Controlling dimension: millimeters, unless otherwise specified.
2. BSC = Basic lead spacing between centers.
3. Dimensions  $D$  and  $E1$  do not include mold flash protrusions and should be measured from the bottom of the package.
4. Formed leads shall be planar with respect to one another within 0.004 inches at the seating plane.

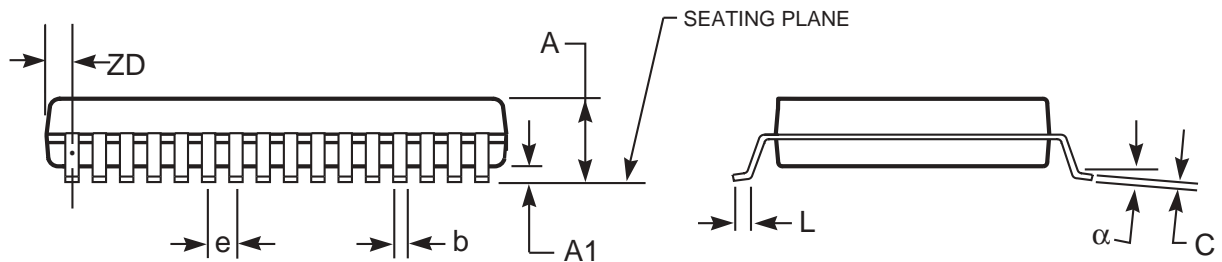

Plastic TSOP (T - Type II)

Symbol	Millimeters		Inches		Millimeters		Inches		Millimeters		Inches	
	Min	Max	Min	Max	Min	Max	Min	Max	Min	Max	Min	Max
Ref. Std.												
No. Leads (N)	32				44				50			
A	—	1.20	—	0.047	—	1.20	—	0.047	—	1.20	—	0.047
A1	0.05	0.15	0.002	0.006	0.05	0.15	0.002	0.006	0.05	0.15	0.002	0.006
b	0.30	0.52	0.012	0.020	0.30	0.45	0.012	0.018	0.30	0.45	0.012	0.018
C	0.12	0.21	0.005	0.008	0.12	0.21	0.005	0.008	0.12	0.21	0.005	0.008
D	20.82	21.08	0.820	0.830	18.31	18.52	0.721	0.729	20.82	21.08	0.820	0.830
E1	10.03	10.29	0.391	0.400	10.03	10.29	0.395	0.405	10.03	10.29	0.395	0.405
E	11.56	11.96	0.451	0.466	11.56	11.96	0.455	0.471	11.56	11.96	0.455	0.471
e	1.27 BSC		0.050 BSC		0.80 BSC		0.032 BSC		0.80 BSC		0.031 BSC	
L	0.40	0.60	0.016	0.024	0.41	0.60	0.016	0.024	0.40	0.60	0.016	0.024
ZD	0.95 REF		0.037 REF		0.81 REF		0.032 REF		0.88 REF		0.035 REF	
$\alpha$	0°	5°	0°	5°	0°	5°	0°	5°	0°	5°	0°	5°

Copyright © 2003 Integrated Silicon Solution, Inc. All rights reserved. ISSI reserves the right to make changes to this specification and its products at any time without notice. ISSI assumes no liability arising out of the application or use of any information, products or services described herein. Customers are advised to obtain the latest version of this device specification before relying on any published information and before placing orders for products.

Integrated Silicon Solution, Inc. — [www.issi.com](http://www.issi.com) — 1-800-379-4774

Rev. F  
06/18/03