

DATA SHEET

For a complete data sheet, please also download:

- The IC04 LOCMOS HE4000B Logic Family Specifications HEF, HEC
- The IC04 LOCMOS HE4000B Logic Package Outlines/Information HEF, HEC

HEF40192B

MSI

4-bit up/down decade counter

Product specification
File under Integrated Circuits, IC04

January 1995

4-bit up/down decade counter

HEF40192B
MSI

DESCRIPTION

The HEF40192B is a 4-bit synchronous up/down decade counter. The counter has a count-up clock input (CP_U), a count-down clock input (CP_D), an asynchronous parallel load input (\overline{PL}), four parallel data inputs (P_0 to P_3), an asynchronous master reset input (MR), four counter outputs (O_0 to O_3), an active LOW terminal count-up (carry) output (\overline{TC}_U) and an active LOW terminal count-down (borrow) output (\overline{TC}_D).

The counter outputs change state on the LOW to HIGH transition of either clock input. However, for correct

counting, both clock inputs cannot be LOW simultaneously. The outputs \overline{TC}_U and \overline{TC}_D are normally HIGH. When the circuit has reached the maximum count state of '9', the next HIGH to LOW transition of CP_U will cause \overline{TC}_U to go LOW. \overline{TC}_U will stay LOW until CP_U goes HIGH again. Likewise, output \overline{TC}_D will go LOW when the circuit is in the zero state and CP_D goes LOW. When \overline{PL} is LOW, the information on P_0 to P_3 is asynchronously loaded into the counter. A HIGH on MR resets the counter independent of all other input conditions. The counter stages are of a static toggle type flip-flop.

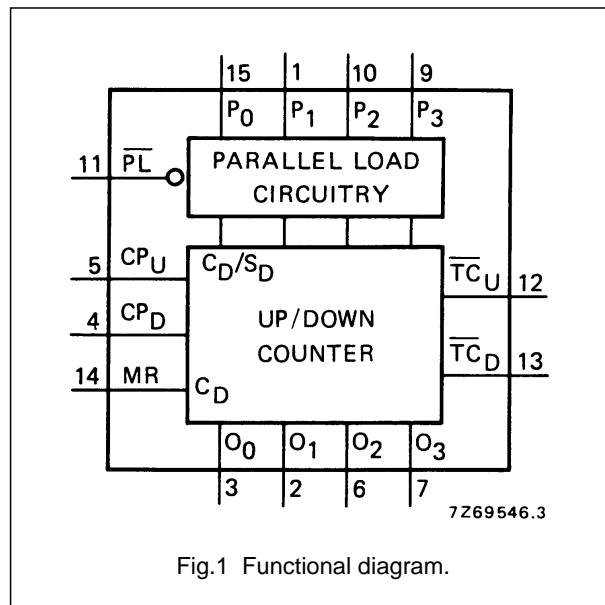

Fig.1 Functional diagram.

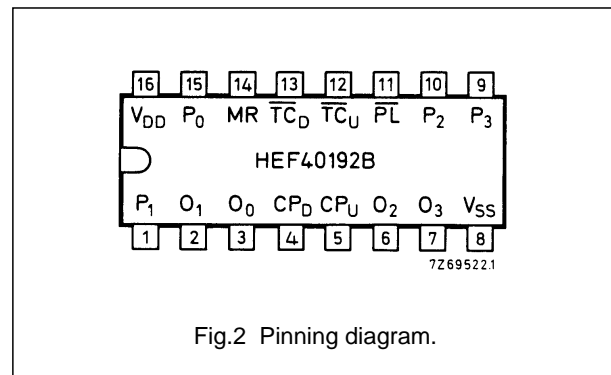

Fig.2 Pinning diagram.

PINNING

\overline{PL}	parallel load input (active LOW)
P_0 to P_3	parallel data inputs
CP_U	count-up clock pulse input (LOW to HIGH, edge-triggered)
CP_D	count-down clock pulse input (LOW to HIGH, edge-triggered)
MR	master reset input (asynchronous)
\overline{TC}_U	buffered terminal count-up (carry) output (active LOW)
\overline{TC}_D	buffered terminal count-down (borrow) output (active LOW)
O_0 to O_3	buffered counter outputs

HEF40192BP(N):	16-lead DIL; plastic (SOT38-1)
HEF40192BD(F):	16-lead DIL; ceramic (cerdip) (SOT74)
HEF40192BT(D):	16-lead SO; plastic (SOT109-1)
():	Package Designator North America

FAMILY DATA, I_{DD} LIMITS category MSI

See Family Specifications

4-bit up/down decade counter

HEF40192B
MSI

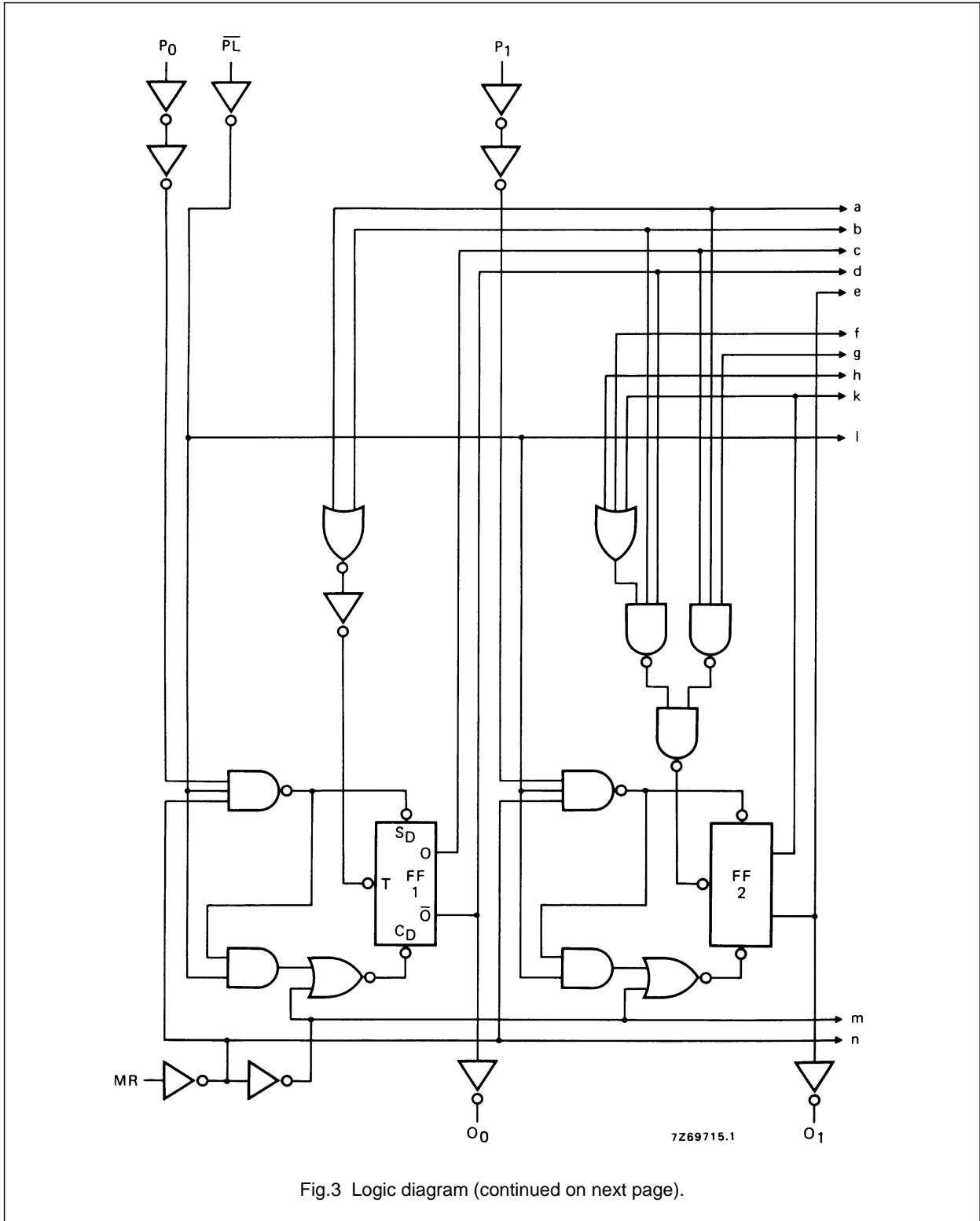

Fig.3 Logic diagram (continued on next page).

4-bit up/down decade counter

HEF40192B
MSI

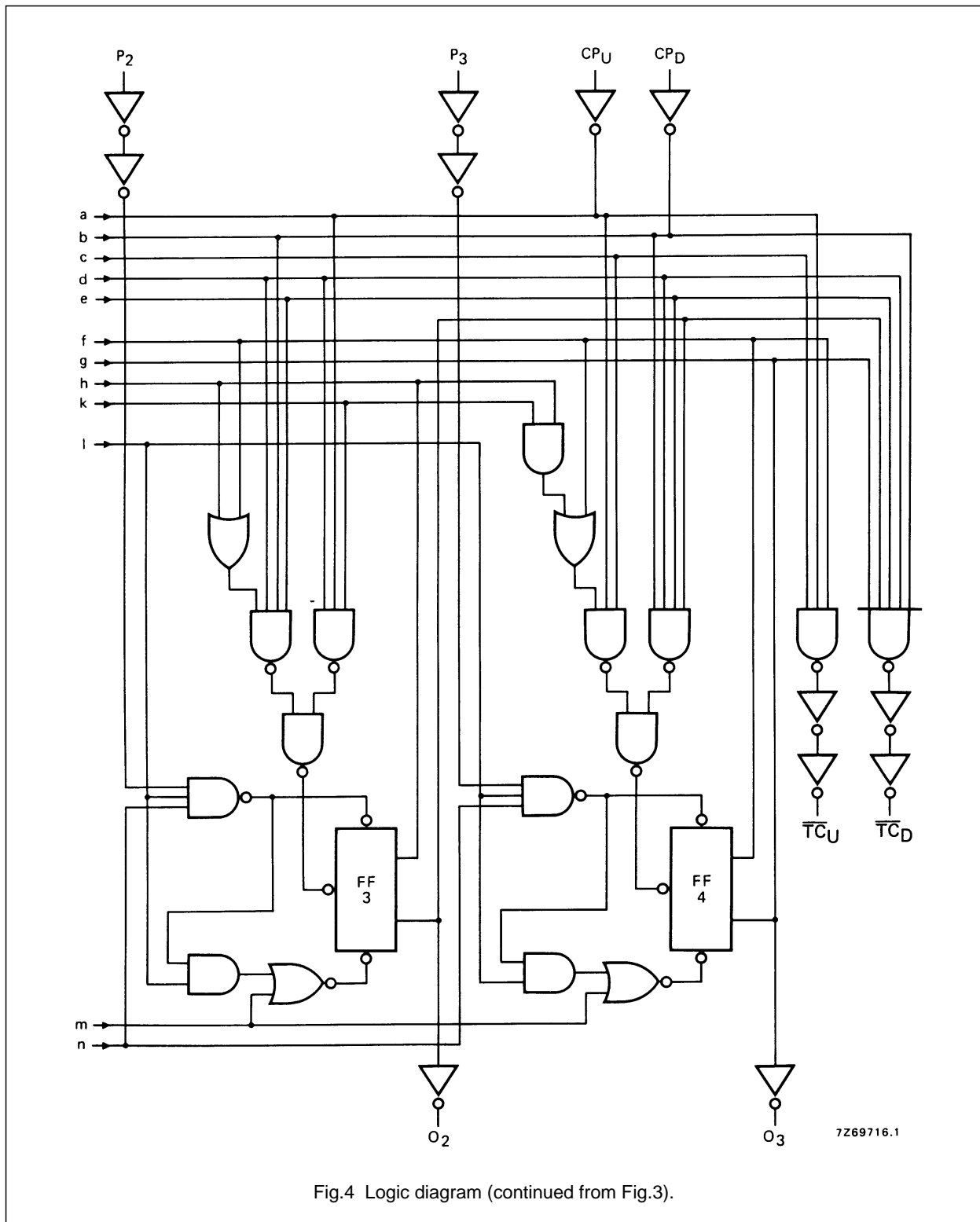



Fig.4 Logic diagram (continued from Fig.3).

4-bit up/down decade counter

HEF40192B
MSI

FUNCTION TABLE

MR	\overline{PL}	CP_U	CP_D	MODE
H	X	X	X	reset (asyn.)
L	L	X	X	parallel load
L	H		H	count-up
L	H	H		count-down

Notes

- H = HIGH state (the more positive voltage)
L = LOW state (the less positive voltage)
X = state is immaterial
 = positive-going transition

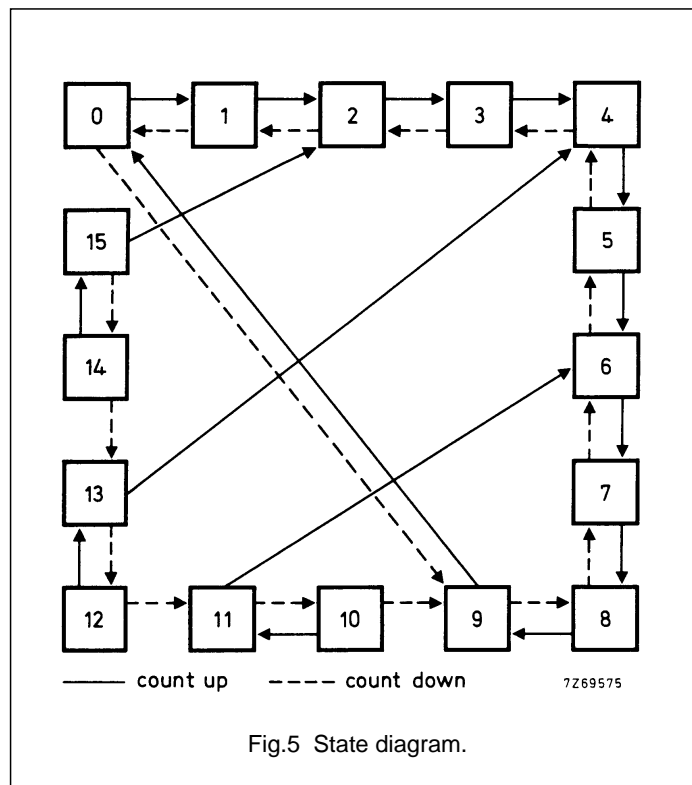

Logic equations for terminal count:

$$\overline{TC}_D = \overline{O_0 \cdot O_1 \cdot O_2 \cdot O_3 \cdot CP_D}$$

$$\overline{TC}_U = O_0 \cdot O_3 \cdot \overline{CP_U}$$

AC CHARACTERISTICS

$V_{SS} = 0\text{ V}$; $T_{amb} = 25\text{ }^\circ\text{C}$; input transition times $\leq 20\text{ ns}$

	V_{DD} V	TYPICAL FORMULA FOR P (μW)	
Dynamic power dissipation per package (P)	5 10 15	$550 f_i + \sum(f_o C_L) \times V_{DD}^2$ $2400 f_i + \sum(f_o C_L) \times V_{DD}^2$ $6500 f_i + \sum(f_o C_L) \times V_{DD}^2$	where f_i = input freq. (MHz) f_o = output freq. (MHz) C_L = load capacitance (pF) $\sum (f_o C_L)$ = sum of outputs V_{DD} = supply voltage (V)

4-bit up/down decade counter

HEF40192B
MSI**AC CHARACTERISTICS** $V_{SS} = 0\text{ V}$; $T_{amb} = 25\text{ °C}$; $C_L = 50\text{ pF}$; input transition times $\leq 20\text{ ns}$

	V_{DD} V	SYMBOL	MIN.	TYP.	MAX.	TYPICAL EXTRAPOLATION FORMULA	
Propagation delays $CP_U \rightarrow O_n$ HIGH to LOW	5	t_{PHL}	210	415	ns	$183\text{ ns} + (0,55\text{ ns/pF}) C_L$	
	10		85	165	ns	$74\text{ ns} + (0,23\text{ ns/pF}) C_L$	
	15		60	120	ns	$52\text{ ns} + (0,16\text{ ns/pF}) C_L$	
	LOW to HIGH	5	t_{PLH}	170	340	ns	$143\text{ ns} + (0,55\text{ ns/pF}) C_L$
		10		70	140	ns	$59\text{ ns} + (0,23\text{ ns/pF}) C_L$
		15		50	100	ns	$42\text{ ns} + (0,16\text{ ns/pF}) C_L$
$CP_D \rightarrow O_n$ HIGH to LOW	5	t_{PHL}	210	420	ns	$183\text{ ns} + (0,55\text{ ns/pF}) C_L$	
	10		85	170	ns	$74\text{ ns} + (0,23\text{ ns/pF}) C_L$	
	15		65	125	ns	$57\text{ ns} + (0,16\text{ ns/pF}) C_L$	
	LOW to HIGH	5	t_{PLH}	170	340	ns	$143\text{ ns} + (0,55\text{ ns/pF}) C_L$
		10		70	140	ns	$59\text{ ns} + (0,23\text{ ns/pF}) C_L$
		15		50	100	ns	$42\text{ ns} + (0,16\text{ ns/pF}) C_L$
$CP_U \rightarrow \overline{TC}_U$ HIGH to LOW	5	t_{PHL}	125	250	ns	$98\text{ ns} + (0,55\text{ ns/pF}) C_L$	
	10		50	100	ns	$39\text{ ns} + (0,23\text{ ns/pF}) C_L$	
	15		35	70	ns	$27\text{ ns} + (0,16\text{ ns/pF}) C_L$	
	LOW to HIGH	5	t_{PLH}	95	185	ns	$68\text{ ns} + (0,55\text{ ns/pF}) C_L$
		10		40	80	ns	$29\text{ ns} + (0,23\text{ ns/pF}) C_L$
		15		30	60	ns	$22\text{ ns} + (0,16\text{ ns/pF}) C_L$
$CP_D \rightarrow \overline{TC}_D$ HIGH to LOW	5	t_{PHL}	140	280	ns	$113\text{ ns} + (0,55\text{ ns/pF}) C_L$	
	10		55	110	ns	$44\text{ ns} + (0,23\text{ ns/pF}) C_L$	
	15		40	80	ns	$32\text{ ns} + (0,16\text{ ns/pF}) C_L$	
	LOW to HIGH	5	t_{PLH}	100	195	ns	$73\text{ ns} + (0,55\text{ ns/pF}) C_L$
		10		40	85	ns	$29\text{ ns} + (0,23\text{ ns/pF}) C_L$
		15		30	65	ns	$22\text{ ns} + (0,16\text{ ns/pF}) C_L$
$MR \rightarrow O_n$ HIGH to LOW	5	t_{PHL}	195	390	ns	$168\text{ ns} + (0,55\text{ ns/pF}) C_L$	
	10		80	160	ns	$69\text{ ns} + (0,23\text{ ns/pF}) C_L$	
	15		60	120	ns	$52\text{ ns} + (0,16\text{ ns/pF}) C_L$	
$MR \rightarrow \overline{TC}_U$ LOW to HIGH	5	t_{PLH}	145	285	ns	$118\text{ ns} + (0,55\text{ ns/pF}) C_L$	
	10		60	115	ns	$49\text{ ns} + (0,23\text{ ns/pF}) C_L$	
	15		45	90	ns	$37\text{ ns} + (0,16\text{ ns/pF}) C_L$	
$MR \rightarrow \overline{TC}_D$ HIGH to LOW	5	t_{PHL}	365	730	ns	$338\text{ ns} + (0,55\text{ ns/pF}) C_L$	
	10		130	265	ns	$119\text{ ns} + (0,23\text{ ns/pF}) C_L$	
	15		100	205	ns	$92\text{ ns} + (0,16\text{ ns/pF}) C_L$	
$\overline{PL} \rightarrow O_n$ HIGH to LOW	5	t_{PHL}	185	360	ns	$158\text{ ns} + (0,55\text{ ns/pF}) C_L$	
	10		75	150	ns	$64\text{ ns} + (0,23\text{ ns/pF}) C_L$	
	15		55	110	ns	$47\text{ ns} + (0,16\text{ ns/pF}) C_L$	

4-bit up/down decade counter

HEF40192B
MSI

	V _{DD} V	SYMBOL	MIN.	TYP.	MAX.	TYPICAL EXTRAPOLATION FORMULA	
LOW to HIGH	5	t _{PLH}		145	290	ns	118 ns + (0,55 ns/pF) C _L
	10			60	120	ns	49 ns + (0,23 ns/pF) C _L
	15			45	90	ns	37 ns + (0,16 ns/pF) C _L

AC CHARACTERISTICSV_{SS} = 0 V; T_{amb} = 25 °C; C_L = 50 pF; input transition times ≤ 20 ns

	V _{DD} V	SYMBOL	MIN.	TYP.	MAX.	TYPICAL EXTRAPOLATION FORMULA	
Output transition times HIGH to LOW	5	t _{THL}		60	120	ns	10 ns + (1,0 ns/pF) C _L
	10			30	60	ns	9 ns + (0,42 ns/pF) C _L
	15			20	40	ns	6 ns + (0,28 ns/pF) C _L
LOW to HIGH	5	t _{TLH}		60	120	ns	10 ns + (1,0 ns/pF) C _L
	10			30	60	ns	9 ns + (0,42 ns/pF) C _L
	15			20	40	ns	6 ns + (0,28 ns/pF) C _L
Set-up time P _n → \overline{PL}	5	t _{su}	160	80		ns	see also waveforms Fig.6
	10		60	30		ns	
	15		50	25		ns	
Hold time P _n → \overline{PL}	5	t _{hold}	10	-70		ns	
	10		5	-25		ns	
	15		5	-20		ns	
Minimum CP _U or CP _D pulse width; LOW	5	t _{WCPL}	150	75		ns	
	10		50	25		ns	
	15		35	20		ns	
Minimum MR pulse width; HIGH	5	t _{WMRH}	180	90		ns	
	10		70	35		ns	
	15		60	30		ns	
Minimum \overline{PL} pulse width; LOW	5	t _{WPLL}	120	60		ns	
	10		45	20		ns	
	15		30	15		ns	
Recovery time for MR	5	t _{RMR}	125	65		ns	
	10		70	35		ns	
	15		50	25		ns	
Recovery time for \overline{PL}	5	t _{RPL}	90	45		ns	
	10		35	15		ns	
	15		25	10		ns	
Maximum clock pulse frequency	5	f _{max}	2,5	5		MHz	
	10		7	14		MHz	
	15		9	18		MHz	

4-bit up/down decade counter

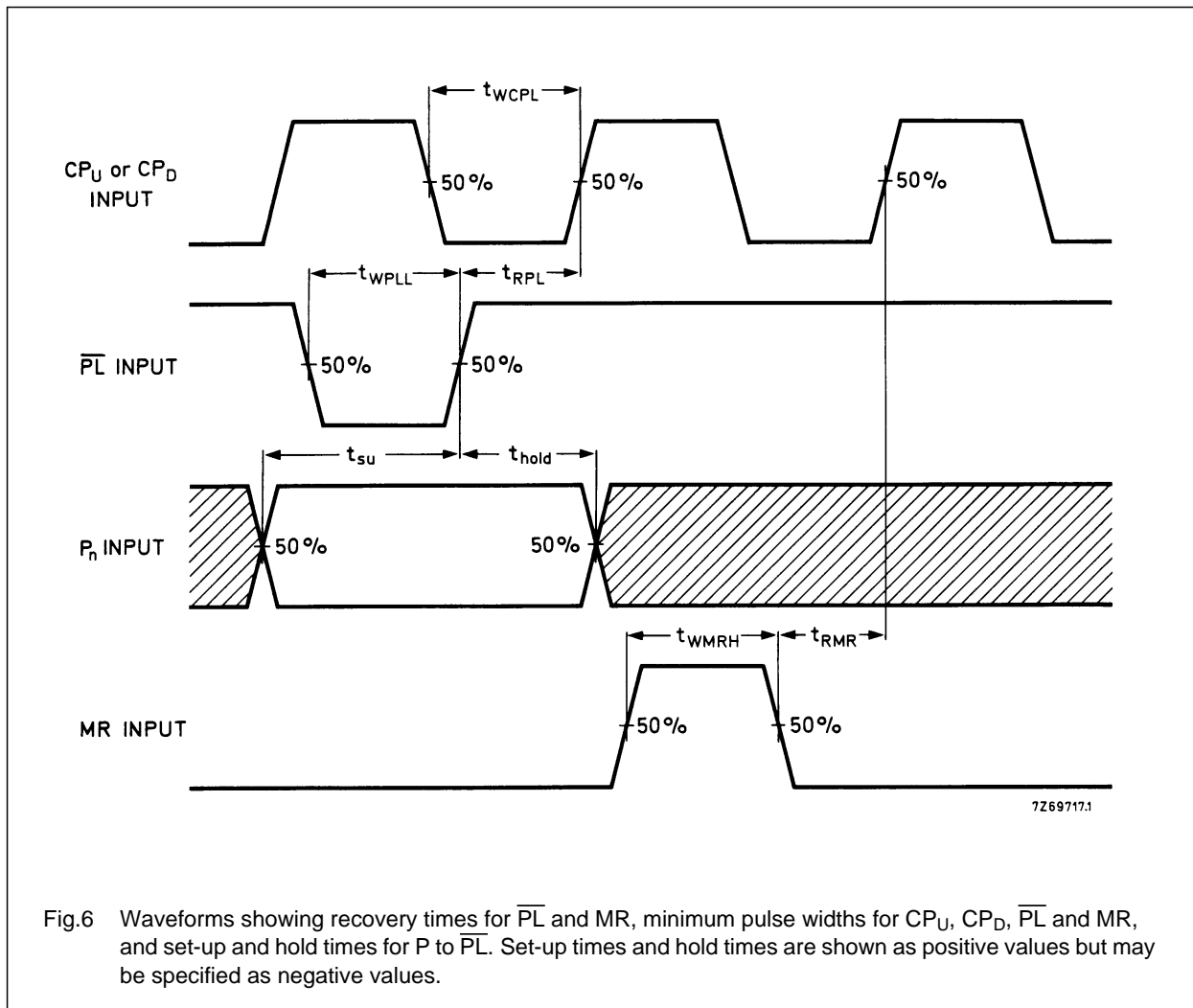
HEF40192B
MSI

4-bit up/down decade counter

HEF40192B
MSI

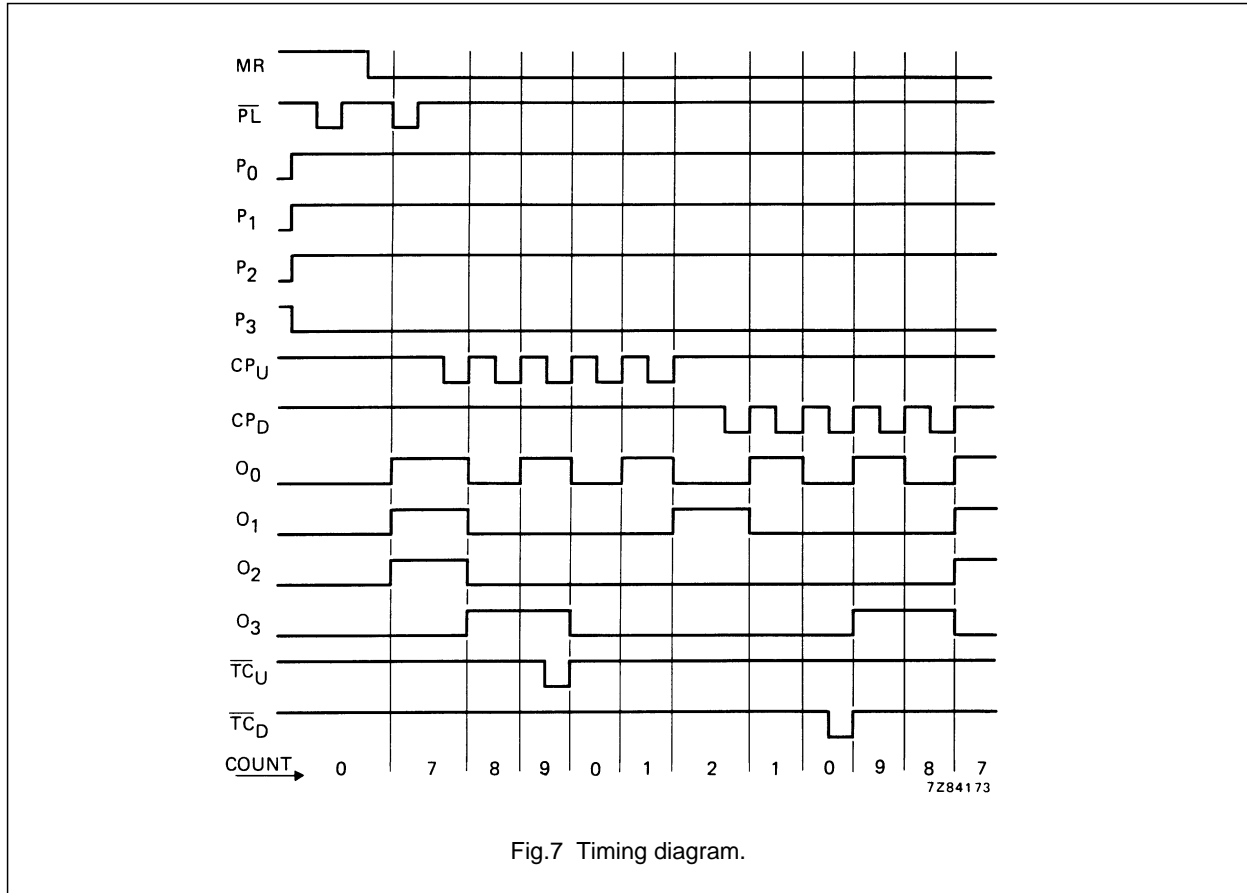

Fig.7 Timing diagram.

APPLICATION INFORMATION

Some examples of applications for the HEF40192B are:

- Up/down difference counting
- Multistage ripple counting
- Multistage synchronous counting.

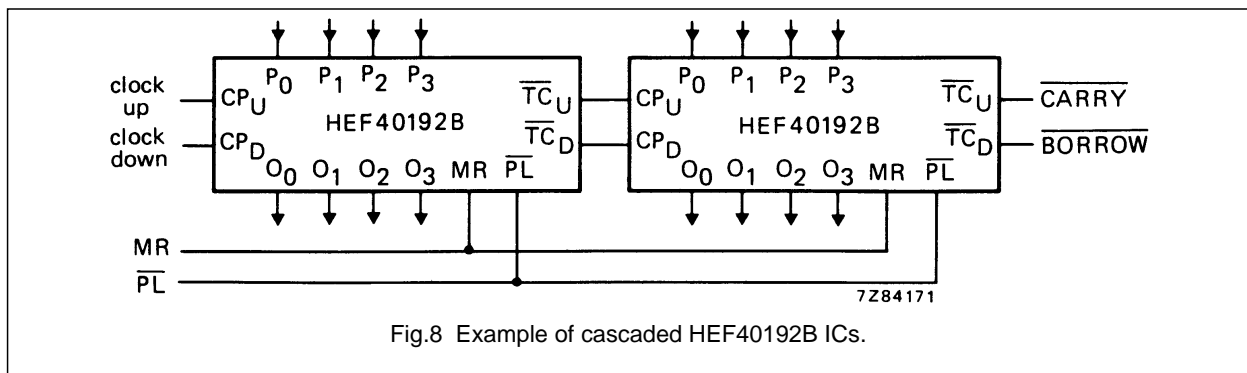

Fig.8 Example of cascaded HEF40192B ICs.