

Consumer Microcircuits Limited

PRODUCT INFORMATION

FX609 Continuously Variable Slope Delta Modulation (CVSD) Codec

Publication D/609/6 July 1998

Features/Applications

- Full Duplex CVSD Codec
- On-Chip Input and Output Filters
- Selectable 3 or 4-Bit Compand Algorithm
- Programmable Sampling Clocks
- Forced Idle Facility
- Powersave Facility
- Low Power 5V CMOS
- Digital Speech Communications
- Time Domain Scramblers
- Digital Cordless Telephone
- Voice Storage
- Digital Delay Lines
- Speech Analysis
- Multiplexers
- General Purpose

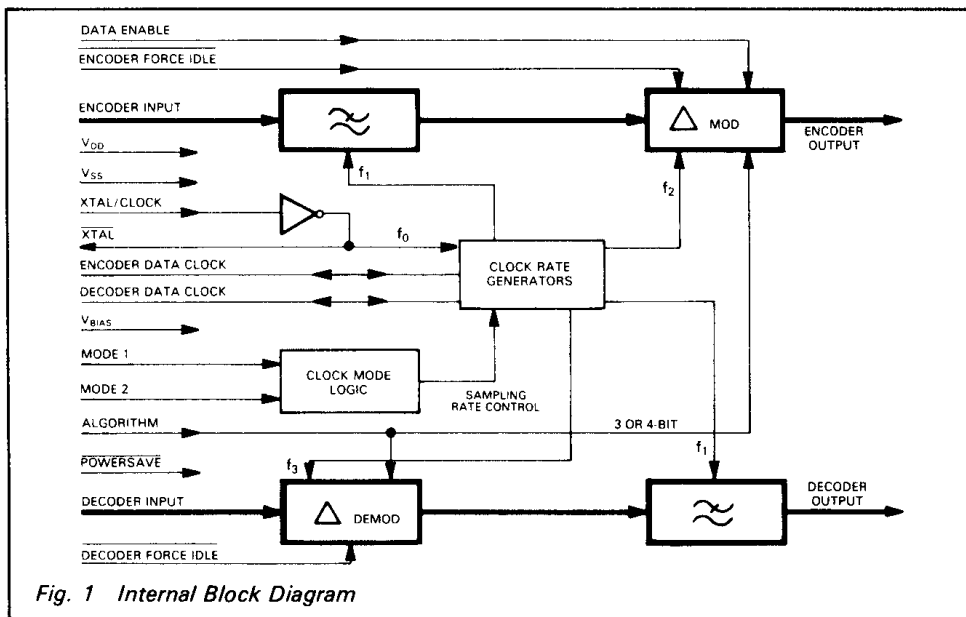

Fig. 1 Internal Block Diagram

FX609

Brief Description

The FX609 is an LSI circuit designed as a Continuously Variable Slope Delta Modulation (CVSD) Codec and is intended for use in voice storage, time domain speech scramblers and digital speech communications equipment. Encode input and decoder output analogue filters are incorporated on-chip and use switched capacitor technology. Sampling clock rates can be programmed to 16, 32 or 64k bits/second from an internal clock generator or may be externally applied in the range 8 to 64k bits/second. Sampling clock frequencies are output for the synchronisation of external circuits. The internal clocks are derived from an on-chip

reference oscillator using an externally connected crystal. The encoder has an enable function for use in multiplexer applications. When not enabled, the encoder output is high impedance (three-state). Forced idle facilities in the encoder cause a perfect 1010... output pattern and in the decoder an output voltage of $V_{DD}/2$. The companding circuits may be operated with a 3 or 4-bit algorithm which is externally selected. The device may be put into standby mode by selection of the powersave facility. The FX609 is a low power, 5 volt CMOS device and is available in 22-pin DIL, 24-pin plastic quad packages.

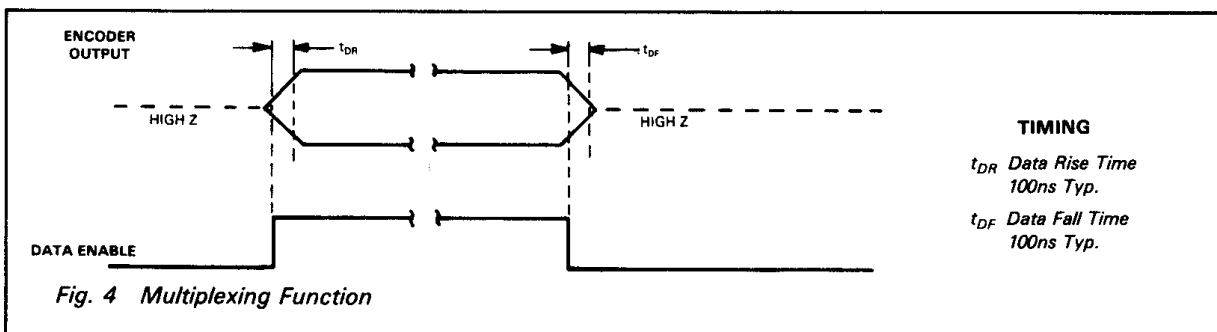
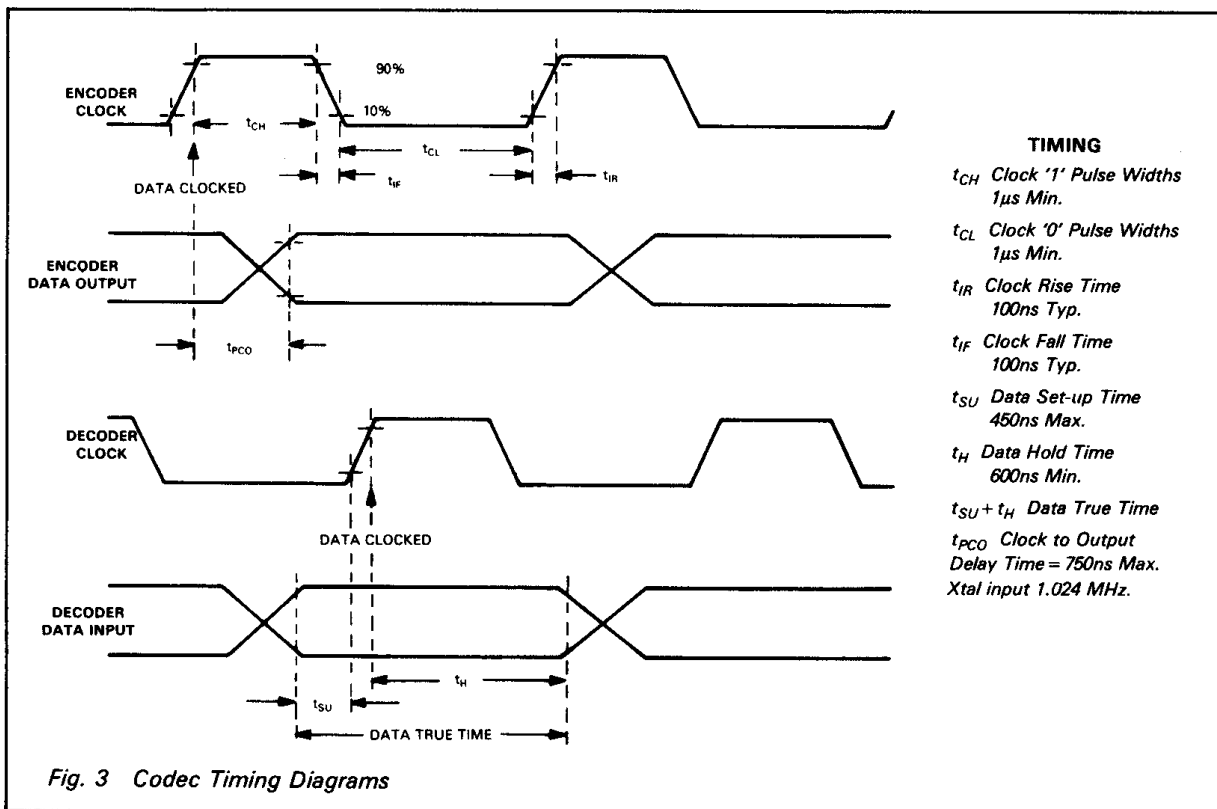
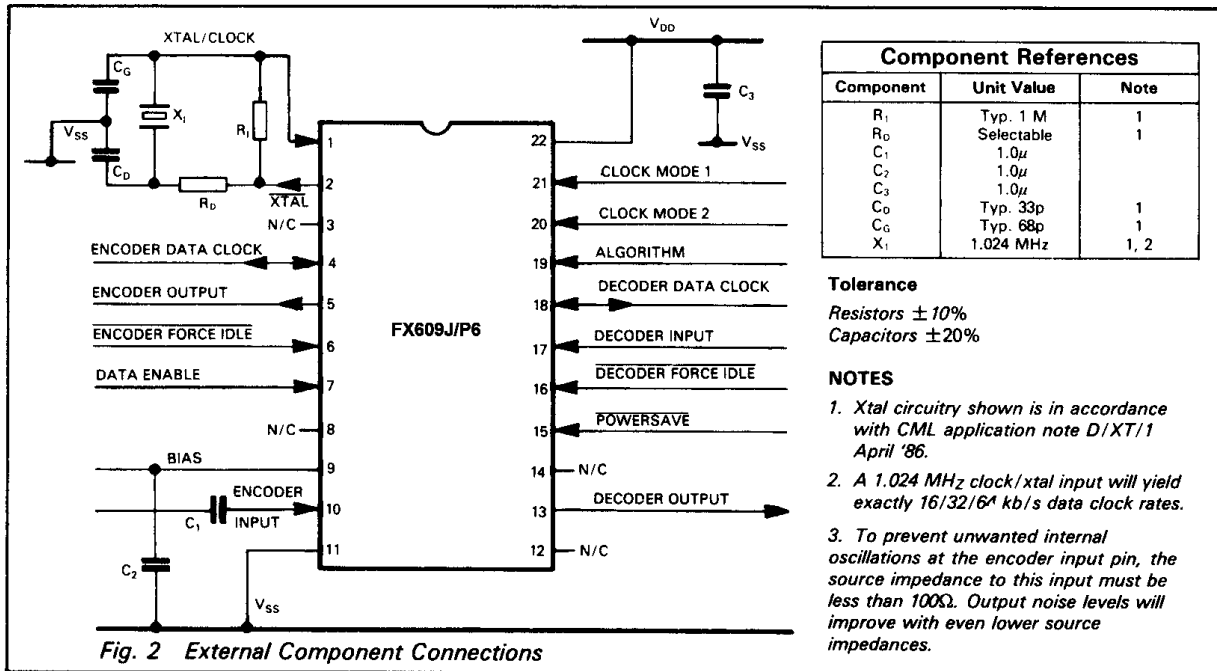

Specifications

Absolute Maximum Ratings

Exceeding the maximum rating can result in device damage. Operation of the device outside the operating limits is not implied.

Supply voltage		-0.3V to 7.0V
Input voltage at any pin (ref $V_{SS} = 0V$)		-0.3 to ($V_{DD} + 0.3V$)
Output sink/source current (supply pins)		$\pm 30mA$
(other pins)		$\pm 20mA$
Total device dissipation @ 25°C		800mW Max.
Derating		10mW/°C
Operating temperature range:	FX609J	-30°C to +85°C (Ceramic)
	FX609LG/L2/P6	-40°C to +85°C (Plastic)
Storage temperature range:	FX609J	-55°C to +125°C (Ceramic)
	FX609LG/L2/P6	-40°C to +85°C (Plastic)

Operating Limits

All characteristics measured using the following parameters unless otherwise specified:

$V_{DD} = 5V$, $T_{amb} = 25°C$, Xtal/Clock (f) = 1.024 MHz, Sample Rate 32kb/s.

[Standard Test Signal 820Hz, ref. 0dB = 489mV (rms)]

Characteristics	See Note	Min.	Typ.	Max.	Unit
Static Values					
Supply Voltage	1	4.5	5.0	5.5	V
Supply Current (Enabled)		—	3.5	—	mA
Supply Current (Powersave)		—	500	—	μA
Inputs Logic '1'		3.5	—	—	V
Inputs Logic '0'		—	—	1.5	V
Outputs Logic '1'		4.0	—	—	V
Outputs Logic '0'		—	—	1.0	V
Digital Input Impedance (logic I/O pins)		—	10	—	M Ω
Digital Input Impedance (logic input pins, pullup resistor)	2	300	—	—	k Ω
Digital Output Impedance		—	4	—	k Ω
Analogue Input Impedance		—	100	—	k Ω
Analogue Output Impedance		—	800	—	Ω
Three State Output leakage Current (output disabled)		—	± 4	—	μA
Insertion Loss		—	0	—	dB
Dynamic Values					
Encoder:					
Analogue Signal Input levels	5	-30	—	+8	dB
Principal Integrator Frequency		—	275	—	Hz
Encoder Passband		—	3400	—	Hz
Comand Time Constant		—	4	—	ms
Decoder:					
Analogue Signal Output levels	5	-30	—	+8	dB
Decoder Passband		300	—	3400	Hz
Encoder Decoder (Full codec):					
Passband		300	—	3400	Hz
Stopband		6	—	10	kHz
Stopband Attenuation		—	60	—	dB
Passband Gain		—	0	—	dB
Passband Ripple		-3	—	+3	dB
Output Noise (Input short circuit)		—	-60	—	dB
Perfect Idle Channel Noise (Encode Forced)		—	-63	—	dB
Group Delay Distortion	3	—	—	—	dB
1000 – 2600Hz		—	—	450	μs
600 – 2800Hz		—	—	750	μs
500 – 3000Hz		—	—	1.5	ms
Xtal/Clock Frequency		500	1024	1500	kHz

- Notes:**
1. Dynamic characteristics specified at 5V only.
 2. All logic Inputs except, Encoder and Decoder Data Clocks.
 3. Group delay distortion for full codec relative to the delay at 820Hz, -20dB at the encoder input.
 4. Relative timings are shown on Figures 3 and 4.
 5. Recommended values—see graph Fig. 7.

Codec Performance

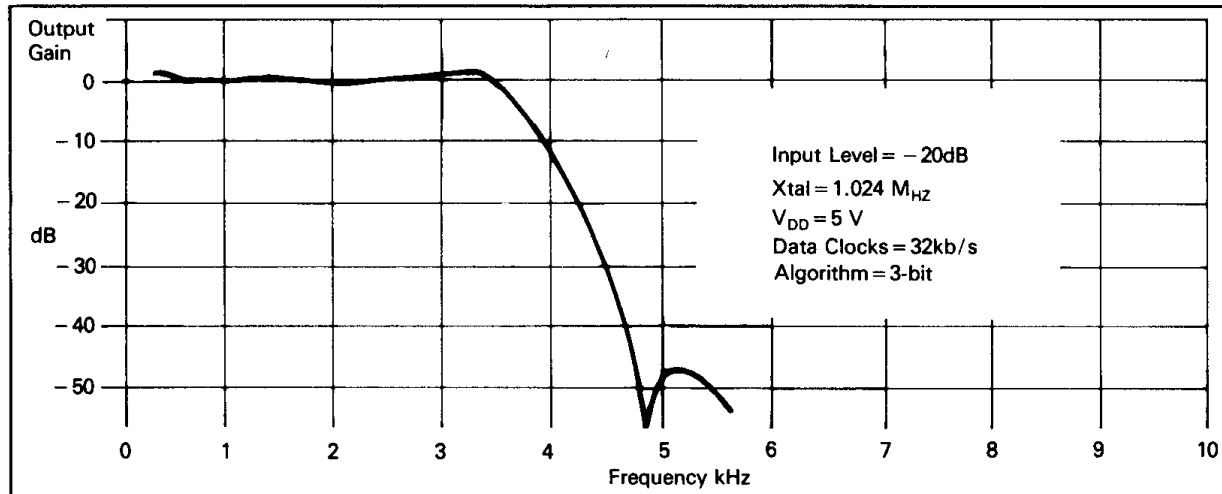

Fig. 5 Typical Codec Frequency Response

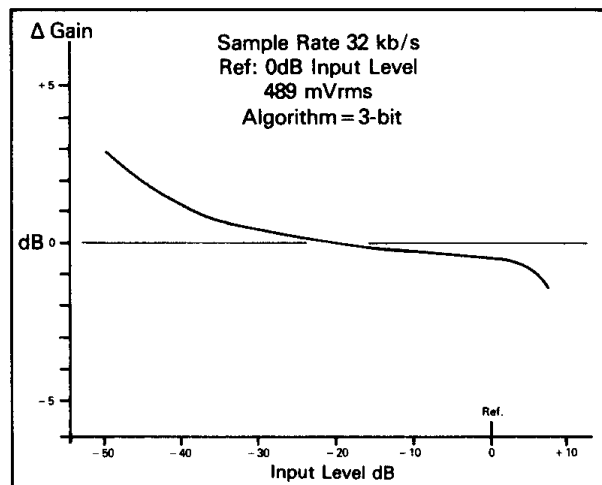

Fig. 6 Typical Variation of Gain with Input Level

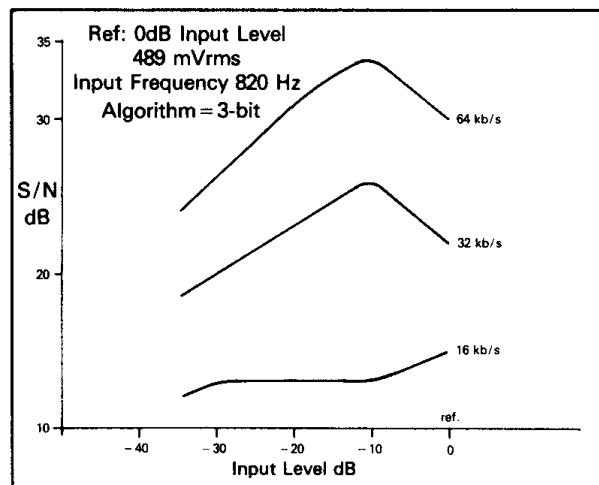

Fig. 7 Typical S/N Ratio with Input Level

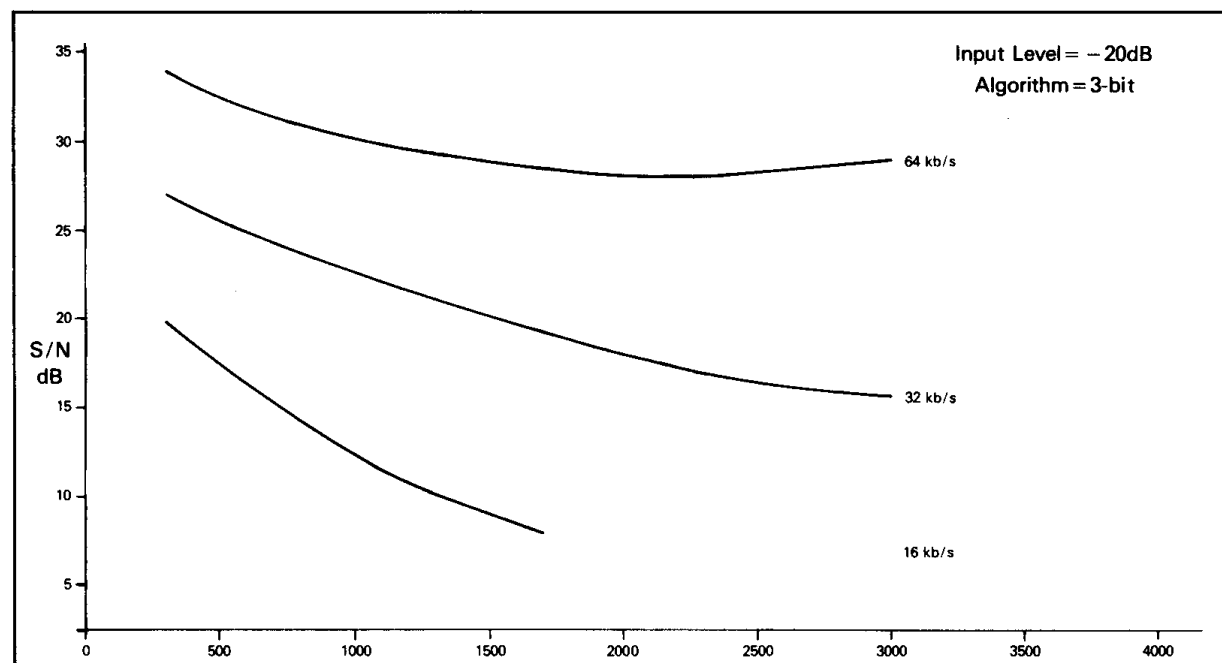

Fig. 8 Typical S/N Ratio with Input Frequency

Package Outlines

The FX609 is available in the package styles outlined below.

Pin 1 identification marking is shown on the relevant diagram and pins on all package styles number anti-clockwise when viewed from the top.

Handling Precautions

The FX609 is a CMOS LSI circuit which includes input protection. However precautions should be taken to prevent static discharges which may cause damage.

FX609J 22-pin cerdip DIL (J3)

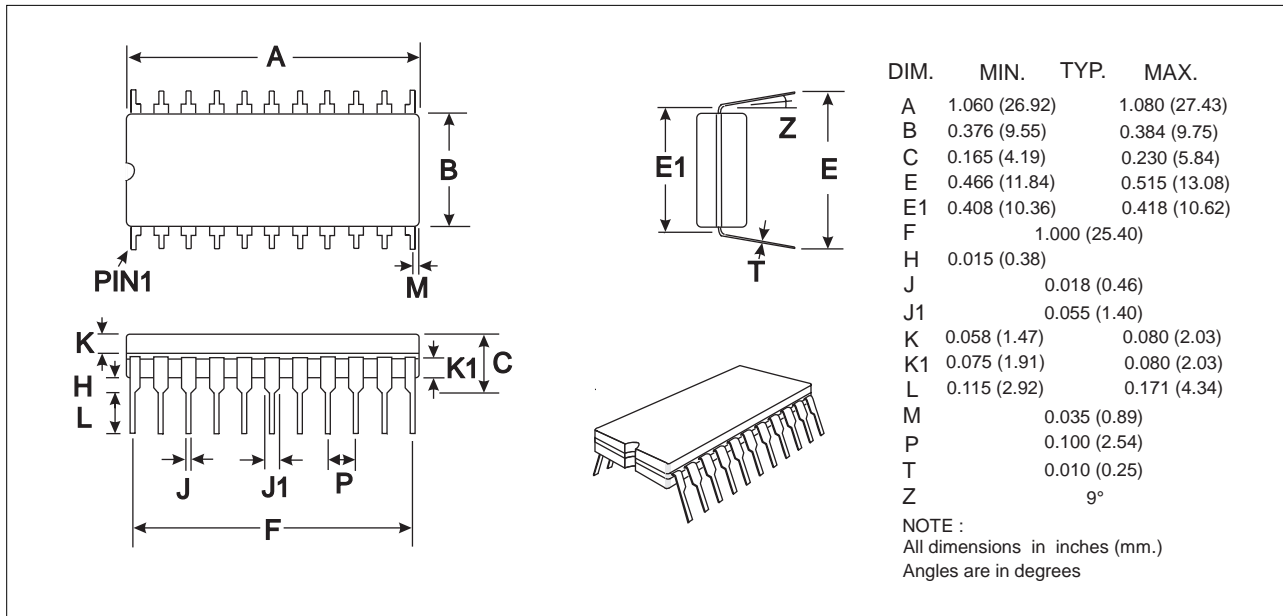

FX609LG 24-pin quad plastic encapsulated bent and cropped (L1)

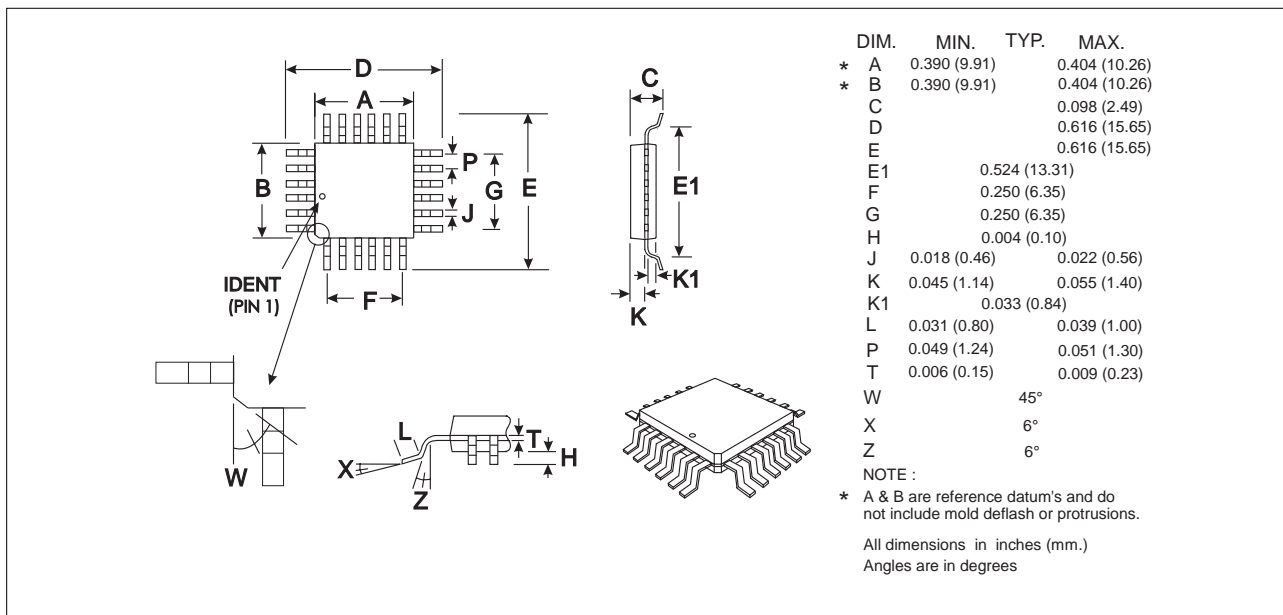

FX609L2 24-lead plastic leaded chip carrier (LS)

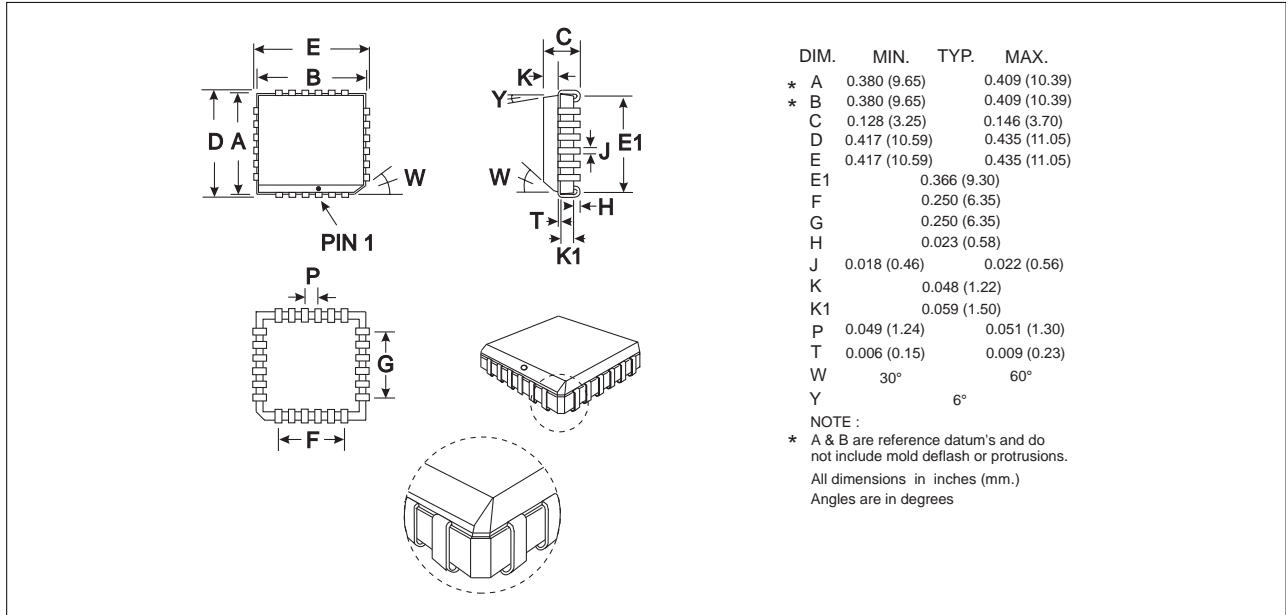

FX609P6 22-pin plastic DIL

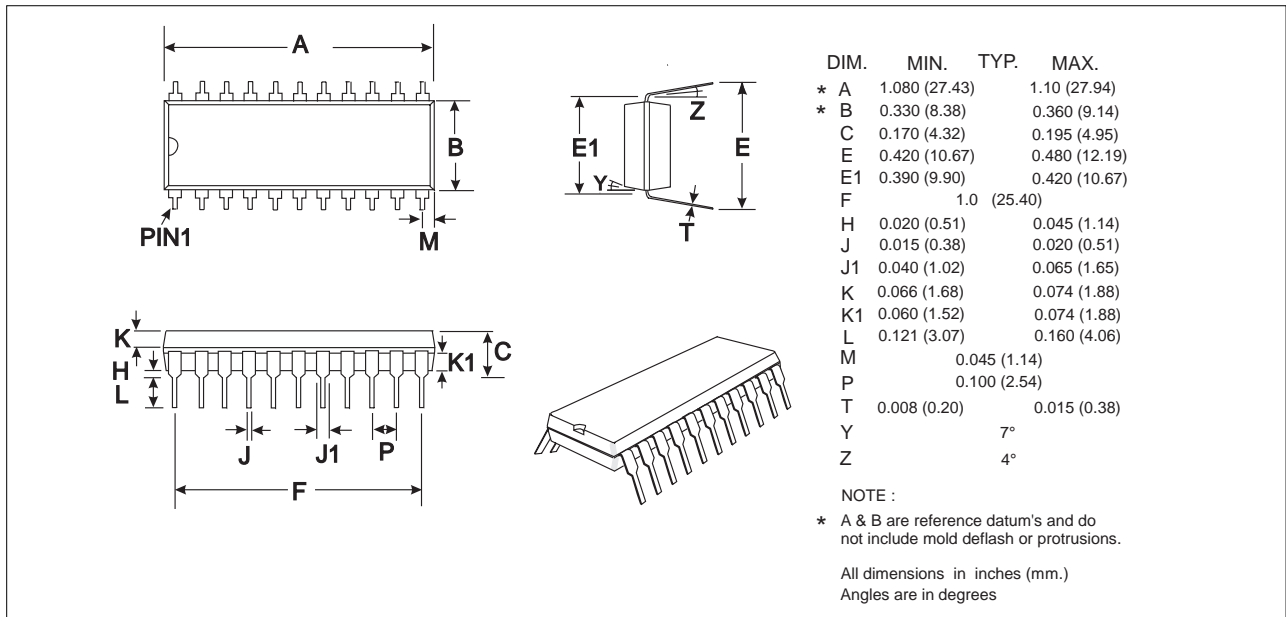

Ordering Information

FX609J 22-pin cerdip DIL (J3)

FX609LG 24-pin quad plastic encapsulated bent and cropped (L1)

FX609L2 24-lead plastic leaded chip carrier (LS)

FX609P6 22-pin plastic DIL

CML does not assume any responsibility for the use of any circuitry described. No circuit patent licences are implied and CML reserves the right at any time without notice to change the said circuitry.

CML Product Data

In the process of creating a more global image, the three standard product semiconductor companies of CML Microsystems Plc (*Consumer Microcircuits Limited (UK)*, *MX-COM, Inc (USA)* and *CML Microcircuits (Singapore) Pte Ltd*) have undergone name changes and, whilst maintaining their separate new names (*CML Microcircuits (UK) Ltd*, *CML Microcircuits (USA) Inc* and *CML Microcircuits (Singapore) Pte Ltd*), now operate under the single title **CML Microcircuits**.

These companies are all 100% owned operating companies of the CML Microsystems Plc Group and these changes are purely changes of name and do not change any underlying legal entities and hence will have no effect on any agreements or contacts currently in force.

CML Microcircuits Product Prefix Codes

Until the latter part of 1996, the differentiator between products manufactured and sold from MXCOM, Inc. and Consumer Microcircuits Limited were denoted by the prefixes MX and FX respectively. These products use the same silicon etc. and today still carry the same prefixes. In the latter part of 1996, both companies adopted the common prefix: CMX.

This notification is relevant product information to which it is attached.

Company contact information is as below:



**CML Microcircuits
(UK) Ltd**
COMMUNICATION SEMICONDUCTORS

Oval Park, Langford, Maldon,
Essex, CM9 6WG, England
Tel: +44 (0)1621 875500
Fax: +44 (0)1621 875600
uk.sales@cmlmicro.com
www.cmlmicro.com



**CML Microcircuits
(USA) Inc.**
COMMUNICATION SEMICONDUCTORS

4800 Bethania Station Road,
Winston-Salem, NC 27105, USA
Tel: +1 336 744 5050,
0800 638 5577
Fax: +1 336 744 5054
us.sales@cmlmicro.com
www.cmlmicro.com



**CML Microcircuits
(Singapore) Pte Ltd**
COMMUNICATION SEMICONDUCTORS

No 2 Kallang Pudding Road, 09-05/
06 Mactech Industrial Building,
Singapore 349307
Tel: +65 7450426
Fax: +65 7452917
sg.sales@cmlmicro.com
www.cmlmicro.com