

# FA5304AP(S)/FA5305AP(S) Bipolar IC For Switching Power Supply Control

## ■ Description

The FA5304AP(S) and FA5305AP(S) are bipolar ICs for switching power supply control and can directly drive a power MOSFET. These ICs contain many functions in a small 8-pin package. With these ICs, a high-performance power supply can be created compactly because not many external components are needed.

## ■ Features

- Drive circuit for connecting a power MOS-FET ( $I_o = \pm 1.5A$ )
- Wide operating frequency range (5 to 600kHz)
- Pulse-by-pulse overcurrent limiting function
  - Positive voltage detection: FA5304AP(S)
  - Negative voltage detection: FA5305AP(S)
- Overload cutoff function (Latch or non-protection mode selectable)
- Output ON/OFF control function by external signals
- Overvoltage cutoff function in latch mode
- Undervoltage malfunction prevention function (ON at 16V and OFF at 8.7V)
- Error amplifier for control by tertiary winding detection
- Low standby current ( $90\mu A$  typ.)
- 8-pin package (DIP/SOP)

## ■ Applications

- Switching power supply for general equipment

## ■ Dimensions, mm

### ● SOP-8

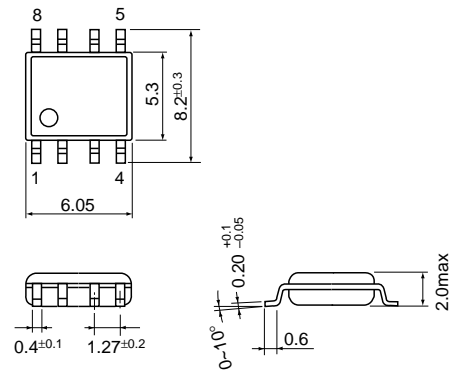

### ● DIP-8

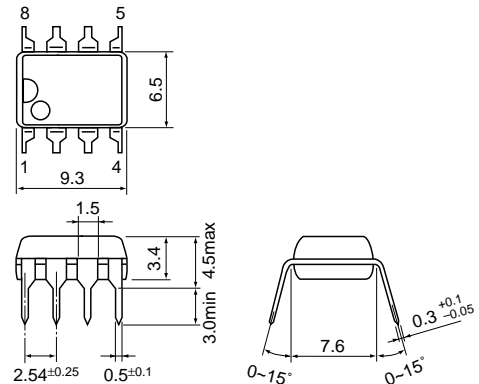

# FA5304AP(S)/FA5305AP(S)

## ■ Block diagram

### ● FA5304AP(S)

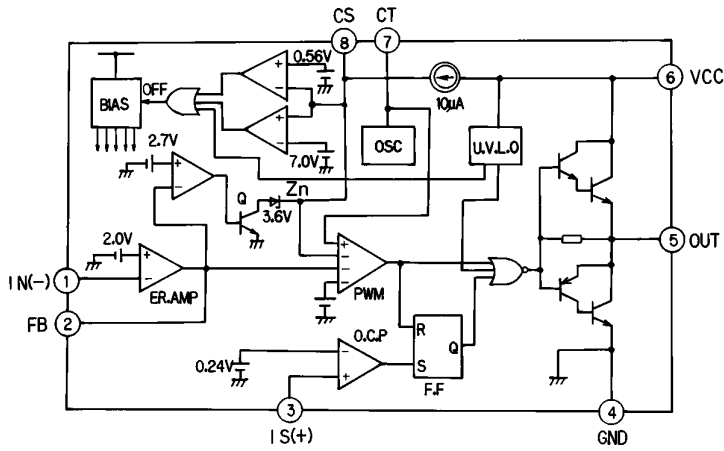

Pin No.	Pin symbol	Description
1	IN (-)	Inverting input to error amplifier
2	FB	Error amplifier output
3	IS (+)	Overcurrent (+) detection
4	GND	Ground
5	OUT	Output
6	VCC	Power supply
7	CT	Oscillator timing capacitor
8	CS	Soft-start and ON/OFF control

### ● FA5305AP(S)

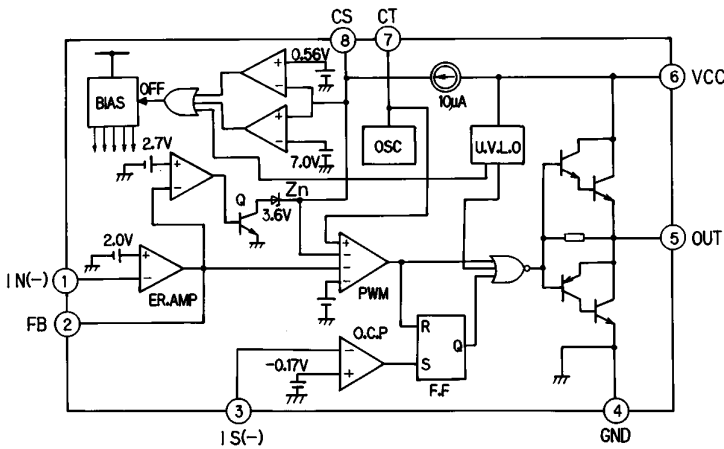

Pin No.	Pin symbol	Description
1	IN (-)	Inverting input to error amplifier
2	FB	Error amplifier output
3	IS (-)	Overcurrent (-) detection
4	GND	Ground
5	OUT	Output
6	VCC	Power supply
7	CT	Oscillator timing capacitor
8	CS	Soft-start and ON/OFF control

### ■ Absolute maximum ratings

Common to FA5304AP(S) and FA5305AP(S)

Item	Symbol	Rating	Unit
Supply voltage	V <sub>CC</sub>	30	V
Output current	I <sub>O</sub>	±1.5	A
Error amplifier input voltage	V <sub>IN</sub>	4	V
Feedback terminal input voltage	V <sub>FB</sub>	4	V
Overcurrent detection terminal input voltage	V <sub>IS</sub>	-0.3 to +4	V
CS terminal input current	I <sub>CS</sub>	2	mA
Total power dissipation (T <sub>a</sub> = 25°C)	P <sub>d</sub>	800 (DIP-8) *1	mW
		550 (SOP-8) *2	
Operating temperature	T <sub>opr</sub>	-30 to +85	°C
Storage temperature	T <sub>stg</sub>	-40 to +150	°C

### ■ Recommended operating conditions

Common to FA5304AP(S) and FA5305AP(S)

Item	Symbol	Min.	Max.	Unit
Supply voltage	V <sub>CC</sub>	10	30	V
Error amplifier feedback resistor	R <sub>NF</sub>	100		kΩ
Soft-start capacitor	C <sub>S</sub>	0.1	1	μF
Oscillation frequency	f <sub>osc</sub>	5	600	kHz

Notes:

\*1 Derating factor T<sub>a</sub> > 25°C : 8.0mW/°C ( on PC board )

\*2 Derating factor T<sub>a</sub> > 25°C : 5.5mW/°C ( on PC board )

### ■ Electrical characteristics (T<sub>a</sub>=25°C, V<sub>CC</sub>=18V, f<sub>osc</sub>=135kHz)

**Oscillator section** Common to FA5304AP(S) and FA5305AP(S)

Item	Symbol	Test condition	Min.	Typ.	Max.	Unit
Oscillation frequency	f <sub>osc</sub>	C <sub>T</sub> = 360pF	112	135	148	kHz
Frequency variation 1 (due to supply voltage change)	f <sub>ΔV</sub>	V <sub>CC</sub> = 10 to 30V		±1		%
Frequency variation 2 (due to temperature change)	f <sub>ΔT</sub>	T <sub>a</sub> = -30 to +85°C		±4		%

**Error amplifier section** Common to FA5304AP(S) and FA5305AP(S))

Item	Symbol	Test condition	Min.	Typ.	Max.	Unit
Reference voltage	V <sub>B</sub>		1.90	2.00	2.10	V
Input bias current	I <sub>B</sub>	V <sub>I</sub> = 2V	-500	-50		nA
Open-loop voltage gain	A <sub>V</sub>		80			dB
Unity-gain bandwidth	f <sub>T</sub>			1.0		MHz
Maximum output voltage (Pin 2)	V <sub>OM+</sub>	R <sub>NF</sub> = 100kΩ	2.70			V
	V <sub>OM-</sub>	R <sub>NF</sub> = 100kΩ			200	mV
Output source current (Pin 2)	I <sub>MO+</sub>	V <sub>OM</sub> = 1V		-100	-50	μA

**Pulse width modulation circuit section** Common to FA5304AP(S) and FA5305AP(S)

Item	Symbol	Test condition	Min.	Typ.	Max.	Unit
Input threshold voltage (Pin 2)	V <sub>TH FBO</sub>	Duty cycle = 0%	0.80	1.00	1.20	V
	V <sub>TH FBM</sub>	Duty cycle = D <sub>MAX</sub>	1.70	1.90	2.10	V
Maximum duty cycle	D <sub>MAX</sub>		42	45	50	%

**Soft-start circuit section** Common to FA5304AP(S) and FA5305AP(S)

Item	Symbol	Test condition	Min.	Typ.	Max.	Unit
Charge current (Pin 8)	I <sub>CHG</sub>	Pin 8 = 0V	-15	-10	-5	μA
Input threshold voltage (Pin 8)	V <sub>TH CSO</sub>	Duty cycle = 0%	0.80	1.00	1.20	V
	V <sub>TH CSM</sub>	Duty cycle = D <sub>MAX</sub>	1.70	1.90	2.10	V

## FA5304AP(S)/FA5305AP(S)

### Overcurrent limiting circuit section

Item	Symbol	Test condition	FA5304AP(S)			FA5305AP(S)			Unit
			Min.	Typ.	Max.	Min.	Typ.	Max.	
Input threshold voltage (Pin 3)	$V_{TH IS}$		0.20	0.24	0.28	-0.20	-0.17	-0.14	V
Overcurrent detection terminal source current	$I_{IS}$	Pin 3 = 0V	-300	-200	-100	-240	-160	-80	$\mu A$
Delay time	$T_{PD IS}$			150			200		ns

### Latch-mode cutoff circuit section Common to FA5304AP(S) and FA5305AP(S)

Item	Symbol	Test condition	Min.	Typ.	Max.	Unit
CS terminal sink current	$I_{SINK CS}$	Pin 8 = 6V, Pin 2 = 1V	40	70	150	$\mu A$
Cutoff threshold voltage (Pin 8)	$V_{TH CS}$		6.5	7.0	7.5	V

### Overload cutoff circuit section Common to FA5304AP(S) and FA5305AP(S)

Item	Symbol	Test condition	Min.	Typ.	Max.	Unit
Cutoff threshold voltage (Pin 2)	$V_{TH FB}$		2.5	2.7	2.9	V

### Undervoltage lock-out circuit section Common to FA5304AP(S) and FA5305AP(S)

Item	Symbol	Test condition	Min.	Typ.	Max.	Unit
OFF-to-ON threshold voltage	$V_{TH ON}$		15.5	16.0	16.5	V
ON-to-OFF threshold voltage	$V_{TH OFF}$		8.20	8.70	9.20	V
Voltage hysteresis	$V_{HYS}$			7.30		V

### Output section Common to FA5304AP(S) and FA5305AP(S)

Item	Symbol	Test condition	Min.	Typ.	Max.	Unit
L-level output voltage	$V_{OL}$	$I_o = 100mA$		1.30	1.80	V
H-level output voltage	$V_{OH}$	$I_o = -100mA, V_{CC} = 18V$	16.0	16.5		V
Rise time	$t_r$	No load		50		ns
Fall time	$t_f$	No load		50		ns

### Output ON/OFF control circuit section Common to FA5304AP(S) and FA5305AP(S)

Item	Symbol	Test condition	Min.	Typ.	Max.	Unit
CS terminal source current	$I_{SOURCE CS}$	Pin 8 = 0V	-15	-10	-5	$\mu A$
OFF-to-ON threshold voltage (Pin 8)	$V_{TH ON}$	CS pin voltage		0.56	0.76	V
ON-to-OFF threshold voltage (Pin 8)	$V_{TH OFF}$	CS pin voltage	0.30	0.42		V

### Overall device Common to FA5304AP(S) and FA5305AP(S)

Item	Symbol	Test condition	Min.	Typ.	Max.	Unit
Standby current	$I_{CC ST}$	$V_{CC} = 14V$		90	150	$\mu A$
Operating-state supply current	$I_{CC OP}$			9	15	mA
OFF-state supply current	$I_{CC OFF}$			1.1	1.8	mA
Cutoff-state supply current	$I_{CCL}$			1.1	1.8	mA

**■ Description of each circuit**

**1. Oscillator** (See block diagram on page 8.)  
 The oscillator generates a triangular waveform by charging and discharging a capacitor. CT pin voltage oscillates between an upper limit of approx. 3.0V and a lower limit of approx. 1.0V. The oscillation frequency is determined by an external capacitance CT connected to CT pin, and approximately given by the following equation:

$$f \text{ (kHz)} = \frac{4.8 \cdot 10^4}{C_T \text{ (pF)}} \dots\dots\dots(1)$$

The recommended oscillation range is between 5k and 600kHz.  
 The oscillator output is connected to a PWM comparator.

**2. Feedback circuit**

Figure 1 gives an example of connection in which built-in error amplifier is used to couple the feedback signal to IN(-) pin. Let n2 be the number of turns of secondary winding L2 and n3 be the number of turns of tertiary winding L3. Vcc and Vout are given by

$$V_{cc} = 2(V) \cdot (R_1 + R_2) / R_2 \dots\dots\dots(2)$$

$$V_{out} \approx (n_2/n_3) \cdot (V_{cc} + V_{D3}) - V_{D2} \dots\dots\dots(3)$$

(where VD2 and VD3 are the forward voltage drops across diodes D2 and D3 respectively).

Here, the following equation must be satisfied to prevent from the malfunction of OUT pin at shutdown.

$$(R_1 \cdot R_2) / (R_1 + R_2) > 11 \text{ k}\Omega \dots\dots\dots(4)$$

Figure 2 gives an example of connection in which an optocoupler is used to couple the feedback signal to the FB pin. If this circuit causes power supply instability, the frequency gain can be decreased by connecting R4 and C4 as shown in figure 2. R4 should be between several tens of ohms to several kilohms and C4 should be between several thousand picofarads to one microfarads.

**3. PWM comparator**

The PWM comparator has four inputs as shown in Figure 3. Oscillator output ① is compared with CS pin voltage ②, FB pin ③, and DT voltage ④. The lowest of three inputs ②, ③, and ④ is compared with output ①. If it is lower than the oscillator output, the PWM comparator output is high, and if it is higher than the oscillator output, the PWM comparator output is low (see Fig. 4).

The IC output voltage is high during when the comparator output is low, and the IC output voltage is low during when the comparator output is high.

When the IC is powered up, CS pin voltage ② controls soft start operation. The output pulse then begins to widen gradually. During normal operation, the output pulse width is determined within the maximum duty cycle (FA5304A, FA5305A: 45%) set by DT voltage ④ under the condition set by feedback signal ③, to stabilize the output voltage.

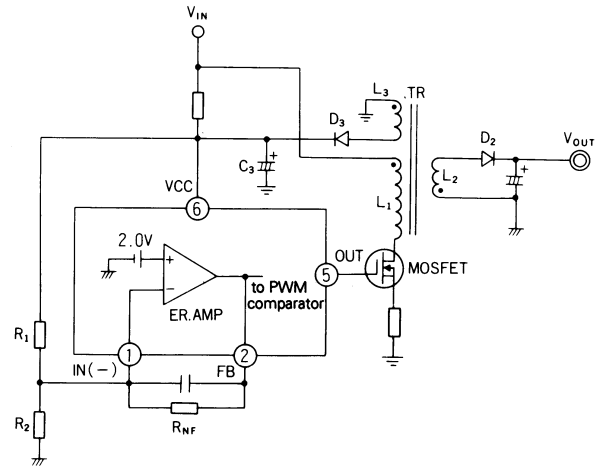

Fig. 1 Configuration with error amplifier

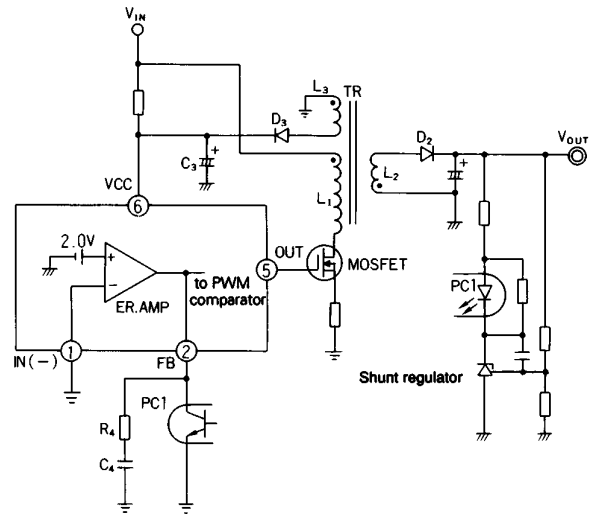

Fig. 2 Configuration with optocoupler (FB pin input)

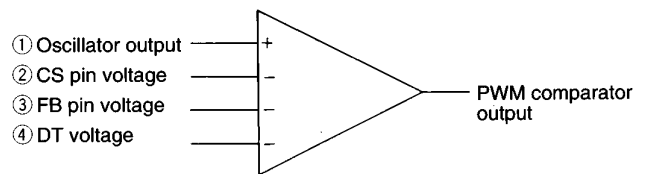

Fig. 3 PWM comparator

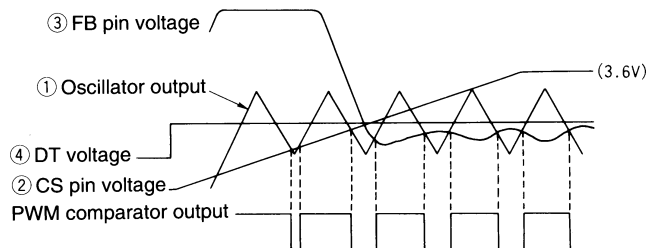

Fig. 4 PWM comparator timing chart

4. CS pin circuit

As shown in Figure 5, capacitor Cs is connected to the CS pin. When power is turned on, the constant current source (10µA) begins to charge capacitor Cs. Accordingly, the CS pin voltage rises as shown in Figure 6. The CS pin is connected to an input of the PWM comparator. The device is in soft-start mode while the CS pin voltage is between 1.0V and 1.9V common to FA5304A and FA5305A. During normal operation, the CS pin is clamped at 3.6V by internal zener diode Zn. If the output voltage drops due to an overload, etc., the clamp voltage shifts from 3.6V to 8.0V. As a result, the CS pin voltage rises to 8.0V. The CS pin is also connected to latch comparator C2. If the pin voltage rises above 7.0V, the output of comparator C2 goes high to turn off the bias circuit, thereby shutting the output down. Comparator C2 can be used not only for shutdown in response to an overload, but also for shutdown in response to an overvoltage. Comparator C1 is also connected to the CS pin, and the bias circuit is turned off and the output is shut down if the CS pin voltage drops below 0.42V. In this way, comparator C1 can also be used for output on/off control. As explained above, the CS pin can be used for soft-start operation, overload and overvoltage output shutdown and output on/off control.

Further details on the four functions of the CS pin are given below.

4.1 Soft start function

Figure 7 shows the soft start circuit. Figure 8 is the soft-start operation timing chart. The CS pin is connected to capacitor Cs. When power is turned on, a 10µA constant-current source begins to charge the capacitor. As shown in the timing chart, the CS pin voltage rises slowly in response to the charging current. The CS pin is connected internally to the PWM comparator. The comparator output pulse slowly widens as shown in the timing chart.

The soft start period can be approximately evaluated by the period ts from the time the IC is activated to the time the output pulse width widens to 30%. Period ts is given by the following equation:

$$ts \text{ (ms)} = 160Cs \text{ (}\mu\text{F)} \dots\dots\dots(2)$$

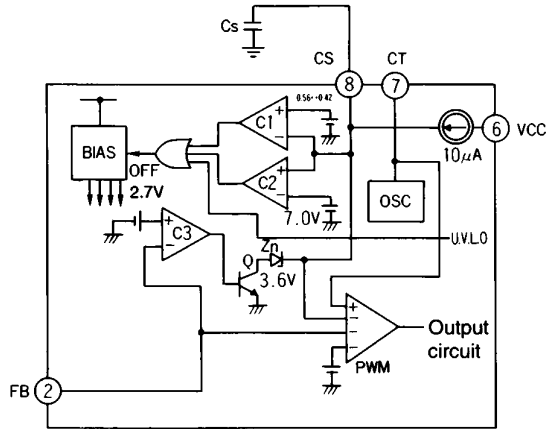

Fig. 5 CS pin circuit

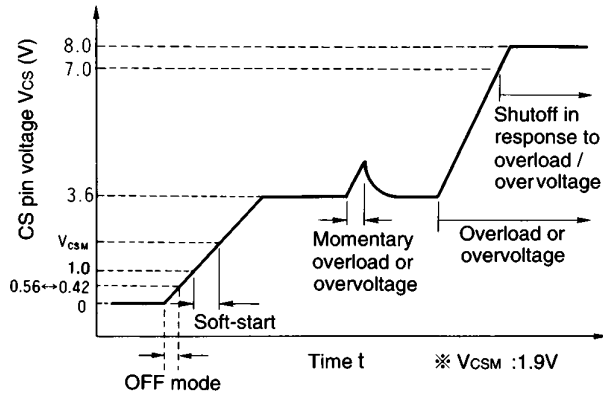

Fig. 6 CS pin waveform

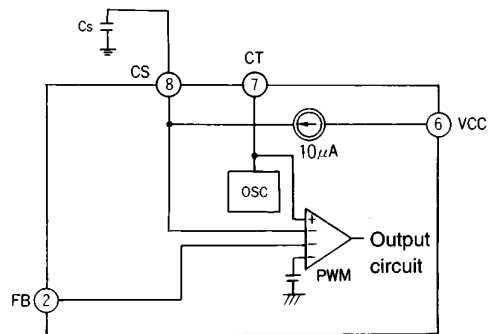

Fig. 7 Soft-start circuit

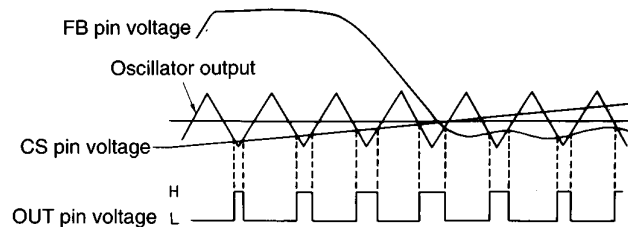

Fig. 8 Soft-start timing chart

**4.2 Overload shutdown**

Figure 9 shows the overload shutdown circuit, and Figure 10 is a timing chart which illustrates overload shutdown operation. If the output voltage drops due to an overload or short-circuit, the output voltage of the FB pin rises. If FB pin voltage exceeds the reference voltage (2.7V) of comparator C3, the output of comparator C3 switches low to turn transistor Q off. In normal operation, transistor Q is on and the CS pin is clamped at 3.6V by zener diode Zn. With Q off, the clamp is released and the 10µA constant-current source begins to charge capacitor Cs again and the CS pin voltage rises. When the CS pin voltage exceeds the reference voltage (7.0V) of comparator C2, the output of comparator C2 switches high to turn the bias circuit off. The IC then enters the latched mode and shuts the output down. Shutdown current consumption is 400µA (Vcc=9V). This current must be supplied through the startup resistor. The IC then discharges the MOSFET gates. Shutdown operation initiated by an overload can be reset by lowering supply voltage Vcc below 8.7V or forcing the CS pin voltage below 7.0V. The period toL from the time that the output is short-circuited to the time that the bias circuit turns off is given by the following equation:

$$t_{OL}(ms) = 340C_s(\mu F) \dots \dots \dots (3)$$

**4.3 Overvoltage shutdown**

Figure 11 shows the overvoltage shutdown circuit, and Figure 12 is a timing chart which illustrates overvoltage shutdown operation.

The optocoupler PC1 is connected between the CS and Vcc pins. If the output voltage rises too high, the PC1 turns on to raise the voltage at the CS pin via resistor R6. When the CS pin voltage exceeds the reference voltage (7.0V) of comparator C2, comparator C2 switches high to turn the bias circuit off. The IC then enters the latched mode and shuts the output down. The shutdown current consumption of the IC is 400µA (Vcc=9V). This current must be applied via startup resistor R5.

The IC then discharges the MOSFET gates.

The shutdown operation initiated by an overvoltage condition can be reset by lowering supply voltage Vcc below 8.7V or forcing the CS pin voltage below 7.0V.

During normal operation, the CS pin is clamped by a 3.6V zener diode with a sink current of 150µA max. Therefore, a current of 150µA or more must be supplied by the optocoupler in order to raise the CS pin voltage above 7.0V.

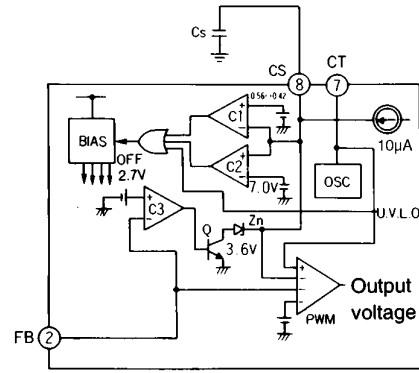

Fig. 9 Overload shutdown circuit

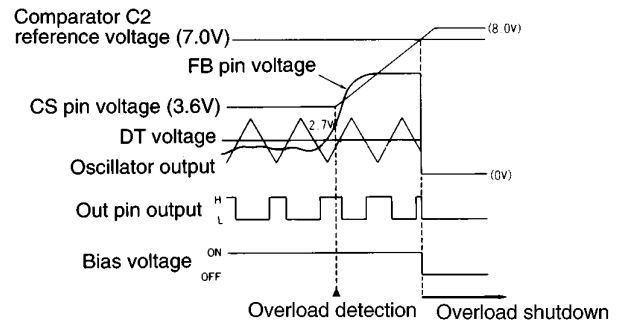

Fig. 10 Overload shutdown timing chart

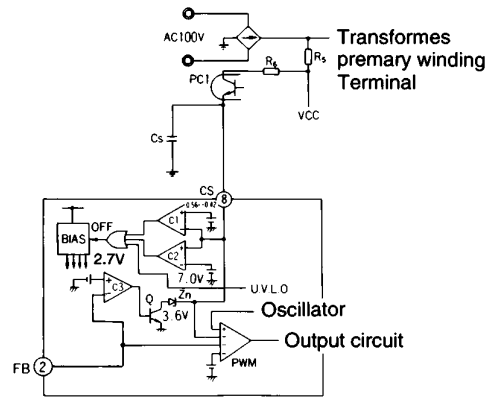

Fig. 11 Overvoltage shutdown circuit

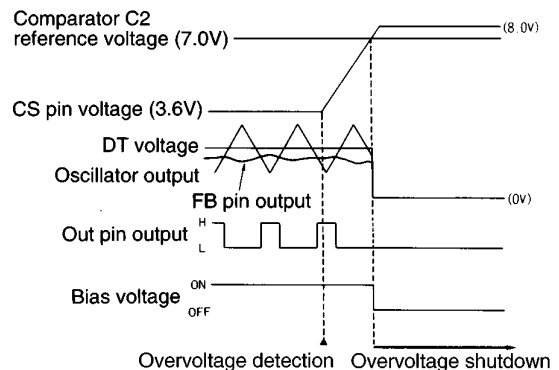

Fig. 12 Overvoltage shutdown timing chart

**4.4 Output ON/OFF control**

The IC can be turned on and off by an external signal applied to the CS pin.

Figure 13 shows the external output on/off control circuit, and Figure 14 is the timing chart.

The IC is turned off if the CS pin voltage falls below 0.42V. The output of comparator C1 switches high to turn the bias circuit off. This shuts the output down. The IC then discharges the MOSFET gates.

The IC turns on if the CS pin is opened for automatic soft start. The power supply then restarts operation.

**5. Overcurrent limiting circuit**

The overcurrent limiting circuit detects the peak value of every drain current pulse of the main switching MOSFET to limit the overcurrent.

The detection threshold is +0.24V for FA5304A with respect to ground as shown in Figure 15.

The drain current of the MOSFET is converted to voltage by resistor  $R_7$  and fed to the IS pin of the IC. If the voltage exceeds the reference voltage (0.24V) of comparator C4, the output of comparator C4 goes high to set flip-flop output Q high. The output is immediately turned off to shut off the current. Flip-flop output Q is reset on the next cycle by the output of the PWM comparator to turn the output on again. This operation is repeated to limit the overcurrent.

If the overcurrent limiting circuit malfunctions due to noise, place an RC filter between the IS pin and the MOSFET.

Figure 16 is a timing chart which illustrates current-limiting operations.

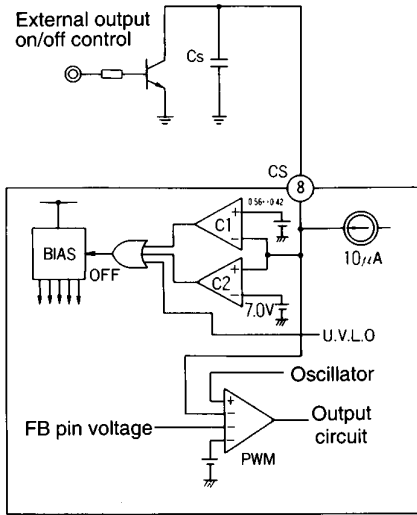

Fig. 13 External output on/off control circuit

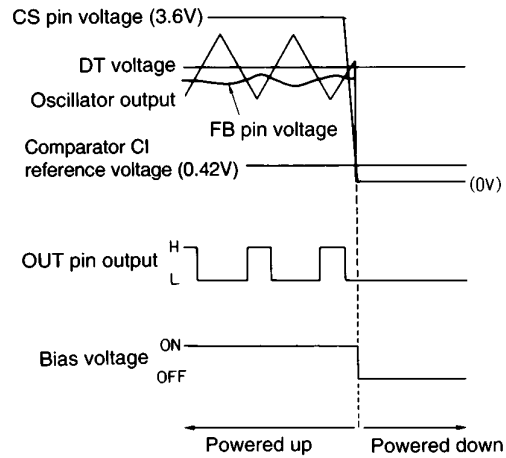

Fig. 14 Timing chart for external output on/off control

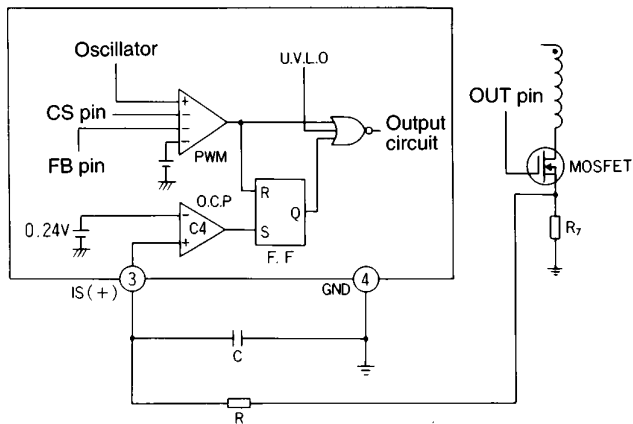

Fig. 15 Overcurrent limiting circuit for FA5304A

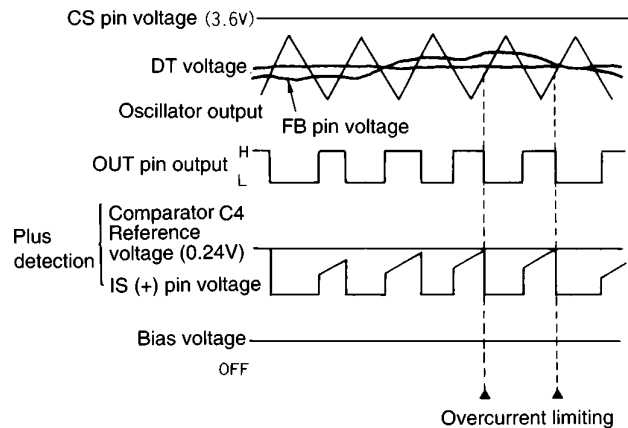

Fig. 16 Overcurrent timing chart for FA5304A



The detection threshold is -0.17v for FA5305A with respect to ground as shown in Figure 17.

The operation is similar to that of FA5304A except the threshold is minus voltage compared to that which is plus voltage for FA5304A.

Figure 18 is a timing chart which illustrates current limiting operations.

**6. Undervoltage lockout circuit**

The IC incorporates a circuit which prevents the IC from malfunctioning when the supply voltage drops. When the supply voltage is raised from 0V, the IC starts operation with  $V_{cc}=16.0V$ .

If the supply voltage drops, the IC shuts its output down when  $V_{cc}=8.7V$ . When the undervoltage lockout circuit operates, the CS pin goes low to reset the IC.

**7. Output circuit**

As shown in Figure 19, the IC's totem-pole output can directly drive the MOSFET. The OUT pin can source and sink currents of up to 1.5A.

If IC operation stops when the undervoltage lockout circuit operates, the gate voltage of the MOSFET goes low and the MOSFET is shut down.

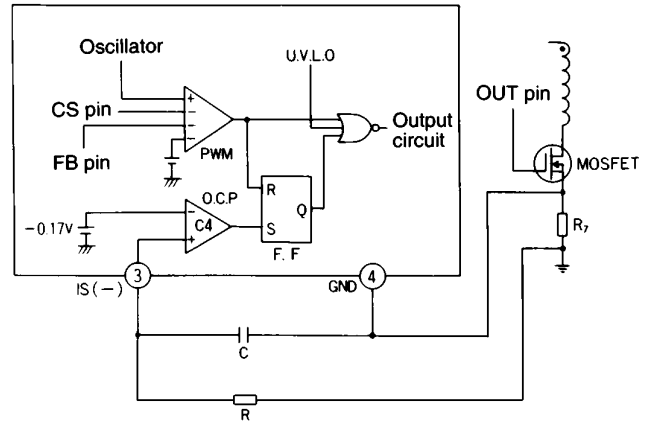

Fig. 17 Overcurrent limiting circuit for FA5305A

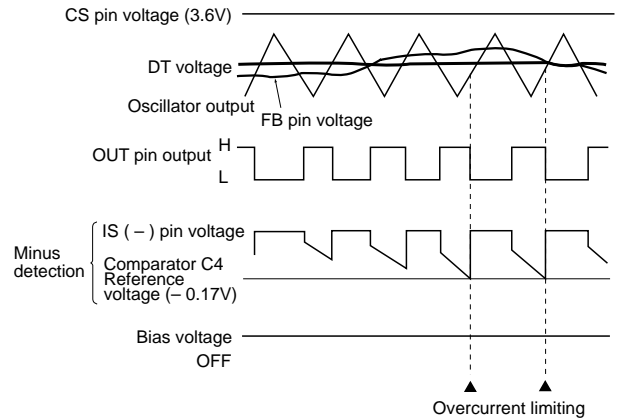

Fig. 18 Overcurrent timing chart for FA5305A

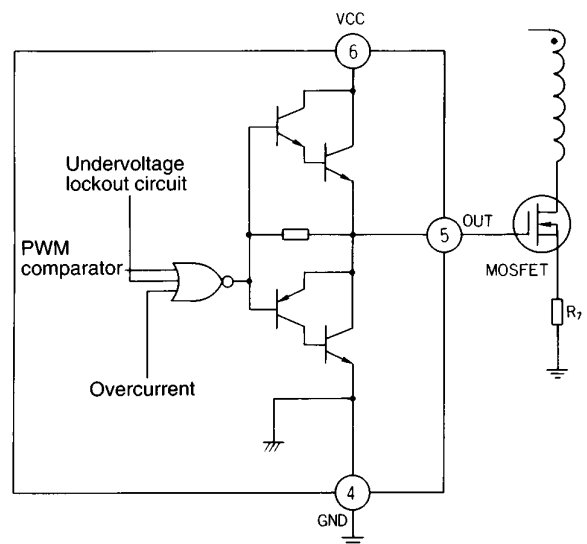

Fig. 19 Output circuit

■ Design advice

1. Startup circuit

It is necessary to start-up IC that the voltage inclination of VCC terminal “dVcc/dt” satisfies the following equation(4).

$$dV_{cc}/dt(V/s) > 1.8 / (C_s(\mu F)) \dots\dots\dots(4)$$

C<sub>s</sub> : capacitor connected between CS terminal and GND

Note that equation (4) must be satisfied in any condition. Also, it is necessary to keep “latch mode” for overload protection or overvoltage protection that the current supplied to VCC terminal through startup resistor satisfies the following equation(5).

$$I_{cc(Lat)} > 0.4mA \text{ for } V_{cc} \geq 9.2V \dots\dots\dots(5)$$

I<sub>cc(Lat)</sub>: Cutoff-state(=Latch mode) supply current

The detail is explained as follows.

(1) Startup circuit connected to AC line directly

Fig. 20 shows a typical startup circuit that a startup resistor R<sub>c</sub> is connected to AC line directly. The period from power-on to startup is determined by R<sub>c</sub>, R<sub>D</sub> and C<sub>A</sub>. R<sub>c</sub>, R<sub>D</sub> and C<sub>A</sub> must be designed to satisfy the following equations.

$$dV_{cc}/dt(V/s) = (1/C_A) \cdot \{(V_{AVE} - V_{con}) / R_c - V_{con} / R_D - I_{ccst}\} > 1.8 / (C_s(\mu F)) \dots\dots\dots(6)$$

$$R_c(k\Omega) < (V_{AVE} - 9.2(V)) / \{0.4 (mA) + (9.2(V) / R_D(k\Omega))\} \dots\dots\dots(7)$$

- V<sub>AVE</sub> = V<sub>ac</sub> • 2/π: Average voltage applied to AC line side of R<sub>c</sub>
- V<sub>ac</sub>: AC input effective voltage
- V<sub>con</sub>: ON threshold of UVLO, 16.5V(max.)
- I<sub>ccst</sub>: Standby current, 0.15 mA(max.)

In this method, V<sub>cc</sub> voltage includes ripple voltage influenced by AC voltage. Therefore, enough dV<sub>cc</sub>/dt required by equation (6) tend to be achieved easily when V<sub>cc</sub> reaches to V<sub>con</sub> even if V<sub>cc</sub> goes up very slowly.

After power-off, V<sub>cc</sub> does not rise up because a voltage applied from bias winding to VCC terminal decreases and the current flowing R<sub>c</sub> becomes zero, therefore, re-startup does not occur after V<sub>cc</sub> falls down below OFF threshold of UVLO until next power-on.

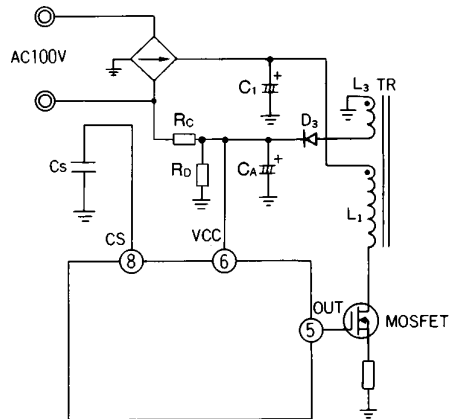

Fig. 20 Startup circuit example(1)

**(2) Startup circuit connected to rectified line**

This method is not suitable for FA5304A and FA5305A, especially concerned with re-startup operation just after power-off or startup which AC input voltage goes up slowly. Fig. 21 shows a startup circuit that a startup resistor RA is connected to rectified line directly.

The period from power-on to startup is determined by RA, RB and CA. RA, RB and CA must be designed to satisfy the following equations.

$$dV_{CC}/dt(V/s) = (1/C_A) \cdot \{ (V_{IN} - V_{CCON})/R_A - V_{CCON}/R_B - I_{CCST} \} > 1.8/(C_S(\mu F)) \dots \dots \dots (8)$$

$$R_A(k\Omega) < (V_{IN} - 9.2(V)) / \{ 0.4(mA) + (9.2(V)/R_B(k\Omega)) \} \dots \dots \dots (9)$$

VIN:  $\sqrt{2} \cdot (\text{AC input effective voltage})$

After power-off, once VCC falls down below OFF threshold voltage, VCC rises up again and re-startup occurs while the capacitor C1 is discharged until approximately zero because VCC voltage rises up by the current flowing RA. This operation is repeated several times. After the repeated operation, IC stops in the condition that VCC voltage is equal to Vcon (=ON threshold) because capacitor C1 is discharged gradually and the decreased VCC inclination is out of the condition required by equation (4). After that, re-startup by power-on can not be guaranteed even when equation (8) is satisfied. The image of that the startup is impossible is shown in Fig. 22. It is necessary to startup IC that supply current Icc (startup) to VCC is over 4mA in the condition of Tj < 100 °C during Vcc is kept at Vcon(≒16V, balance state at Vcon after the repeated operation.

$$I_{CC}(\text{start-up}) > 4mA \dots \dots \dots (10)$$

at Vcc=Vcon, Tj<100°C, after power-off

This balance state that startup is impossible tends to occur at higher temperature. If power-on is done when Vcc is not kept at Vcon (for example: power-off is done and after enough time that C1 is discharged until Vcc can not be pulled up to Vcon), the IC can startup in the condition given by equation(8).

In some cases, such as when the load current of power supply is changed rapidly, you may want to prolong the hold time of the power supply output by means of maintaining Vcc over the off threshold. For this purpose, connect diode D4 and electrolytic capacitor C4 as shown in Fig. 23. This prolongs the hold time of the power supply voltage Vcc regardless of the period from power-on to startup.

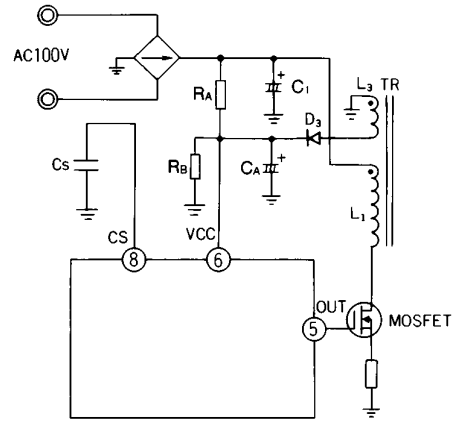

Fig. 21 Startup circuit example(2)

Startup is impossible ( $dV_{CC}/dt < 1.8/C_S$  just before  $V_{CC}$  reaches  $V_{CCON}$ ).  
 $I_{CC} > 4mA$  is necessary for startup at  $T_j < 100^\circ C$  and  $dV_{CC}/dt = 0$ .

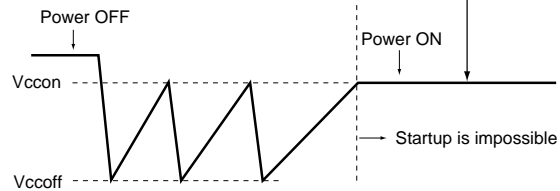

Fig. 22 Image of Vcc waveform when re-startup is impossible

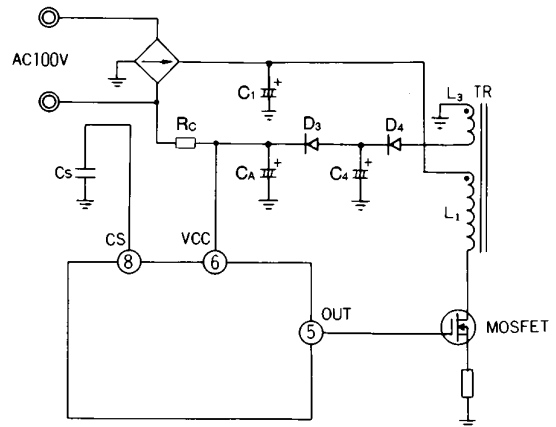

Fig. 23 Startup circuit example(3)

**2. Disabling overload shutdown function**

As shown in Figure 24, connect a 330kΩ to 470kΩ resistor between the CS pin and ground. Then, the CS pin voltage does not rise high enough to reach the reference voltage (7.0V) of the latch comparator, and the IC does not enter the OFF latch mode. With this connection, the overvoltage shutdown function is not available.

**3. Setting soft start period and OFF latch delay independently**

Figure 25 shows a circuit for setting the soft start period and OFF latch delay independently. In this circuit, capacitance Cs determines the soft start period, and capacitance CL determines the OFF latch delay. If the overload shutdown and overvoltage shutdown functions raise the CS pin voltage to around 5V, zener diode Zn becomes conductive to charge CL. The OFF latch delay can be thus prolonged by CL.

**4. Laying out Vcc and ground lines**

Figure 26 and Figure 27 show the recommended layouts of Vcc and ground lines. The bold lines represent paths carrying large currents. The lines must have an adequate thickness.

**5. Sink current setting for CS terminal**

A sink current to CS terminal must be satisfied the following condition to prevent from the malfunction which uncontrolled pulse output generates at OUT terminal when latch-mode protection should be operated for overvoltage.

$$150\mu A < I_{cs(sink)} < 500\mu A \text{ at } V_{cs} = 6.5(V)$$

$I_{cs(sink)}$ : Sink current to CS terminal

Example (for the circuit shown in Fig. 28 )

$$I_{cs(sink)} = (28(V) - 18(V) - 6.5(V)) / 7.5(k\Omega) \approx 467 (\mu A) < 500 (\mu A)$$

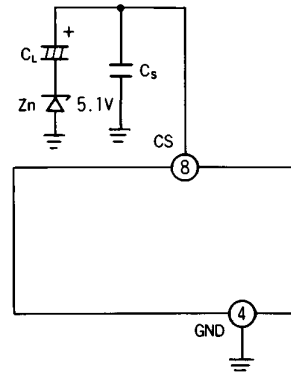

Fig. 25 Independent setting of soft-start period and OFF latch delay

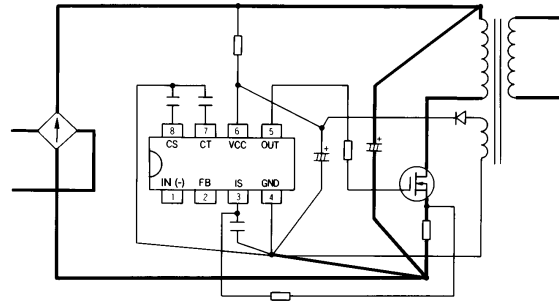

Fig. 26 Vcc line and ground line for FA5304A

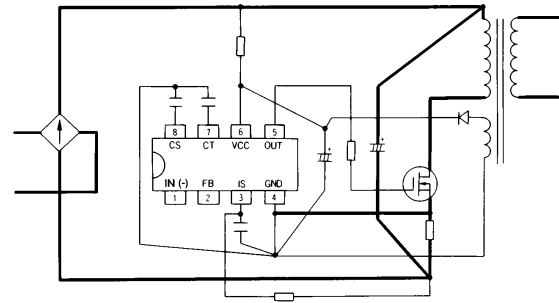

Fig. 27 Vcc line and ground line for FA5305A

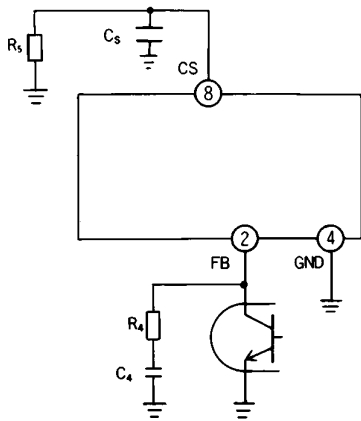

Fig. 24 Disabling overload shutdown function

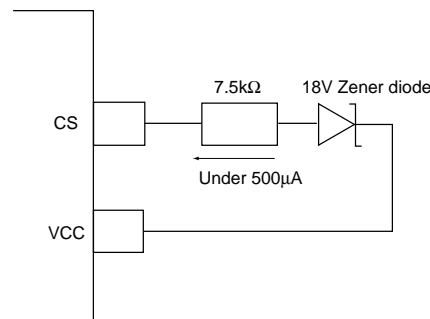

Fig. 28 Setting sink current for CS terminal

## 6. Notice for high frequency operation

### (1) The final pulse

These ICs have the original characteristics about the pulse width at OUT terminal when the IC is stopped by undervoltage lockout, ON/OFF function, or latched mode for overload or overvoltage.

When the IC is stopped, the final pulse width is  $2\mu\text{s}(\text{max.})$  longer than normal pulse width as shown in Figure. 29.

Here, normal pulse width " $A\mu\text{s}$ " is determined by measured condition of the power supply unit, and whole width of final pulse is " $A+2\mu\text{s}(\text{max.})$ ".

Take care of a longer pulse mentioned above for designing or testing the circuit of power supply units.

### (2) Power dissipation and heating

The power dissipation of IC increases and the temperature becomes higher in proportion to the operating frequency, because the driving power of a switching device and the through current of output stage of IC increase. Determine the oscillation frequency so that the junction temperature ( $T_j$ ) does not rise to  $125^\circ\text{C}$ .

$T_j$  is calculated as following equation roughly.

$$T_j = T_c + \theta_j - c \cdot V_{cc} \cdot I_{cc}$$

$T_c$ : Case temperature     $\theta_j$ -c: Thermal resistance between the junction and the case ( $=50^\circ\text{C/W}$ )

$V_{cc}$ : Vcc voltage  
 $I_{cc}$ : Supply current at the VCC terminal

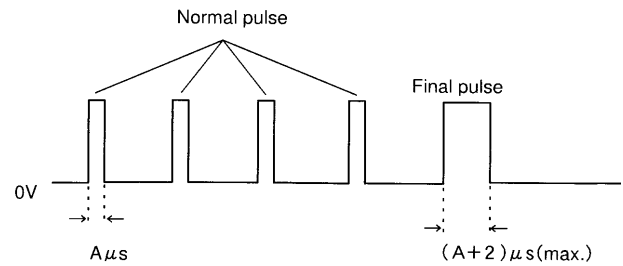
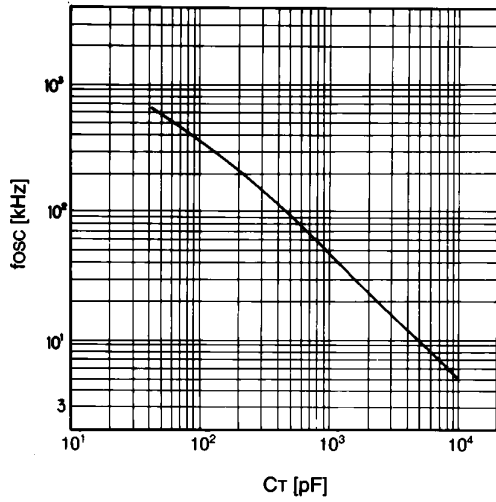

Fig. 29 OUT terminal voltage waveform

■ Characteristic curves (Ta = 25°C)

Oscillation frequency (fosc) vs. timing capacitor capacitance (CT)



Oscillation frequency (fosc) vs. ambient temperature (Ta)

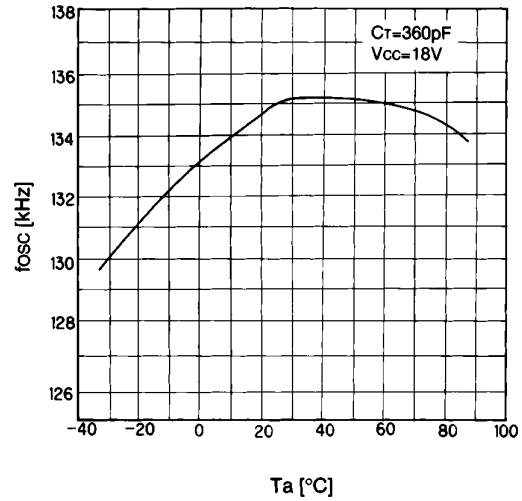

Output duty cycle vs. FB terminal voltage (VFB)

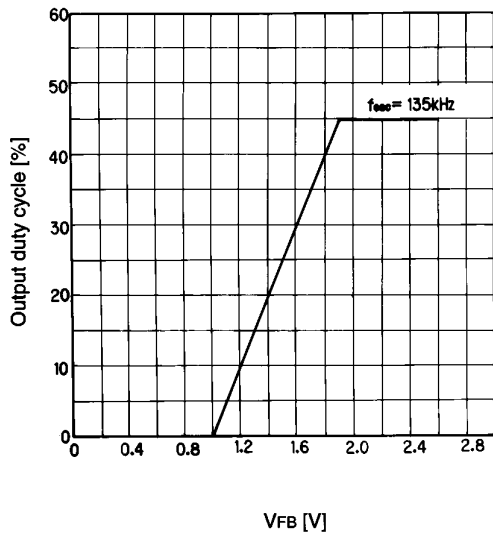

Output duty cycle vs. FB terminal source current (ISOURCE)

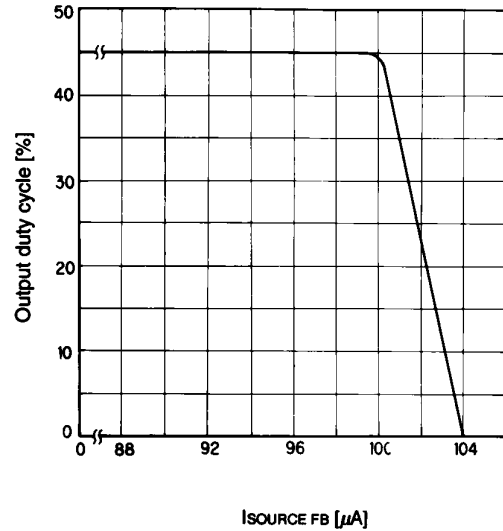

Output duty cycle vs. CS terminal voltage (Vcs)

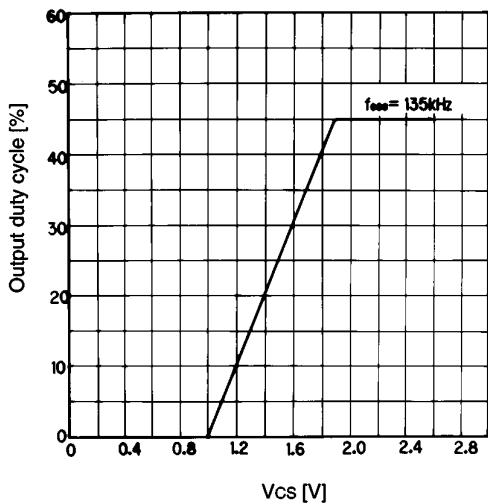

H-level output voltage (VOH) vs. output source current (ISOURCE)

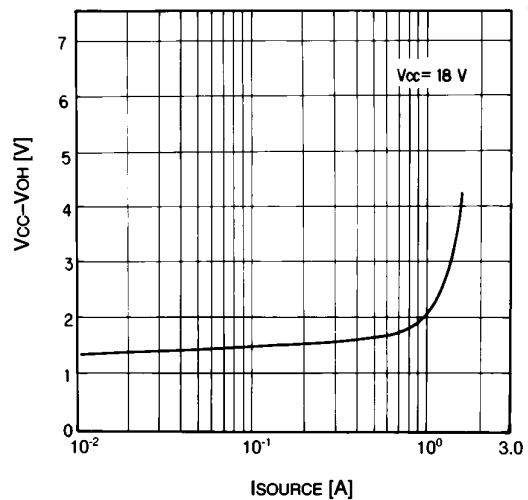

L-level output voltage (VOL) vs. output sink current (ISINK)

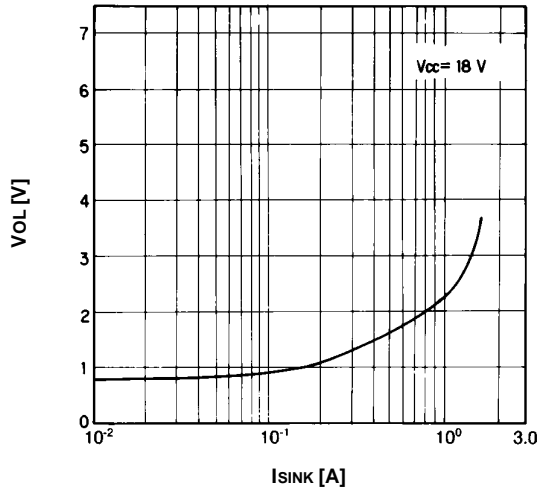

IS (+) terminal threshold voltage (VTH IS(+)) vs. ambient temperature (Ta)

FA5304AP(S)

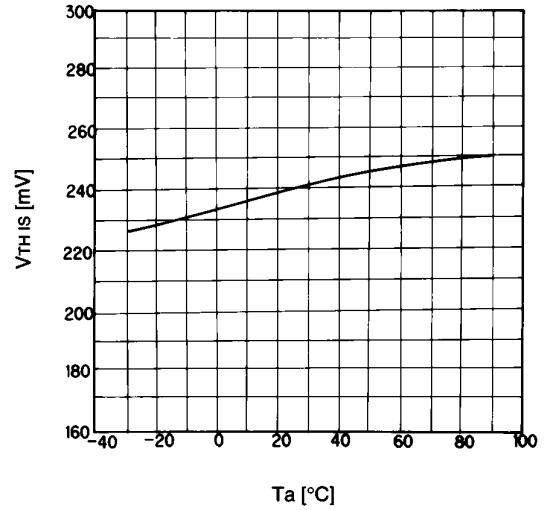

IS (-) terminal threshold voltage (VTH IS(-)) vs. ambient temperature (Ta)

FA5305AP(S)

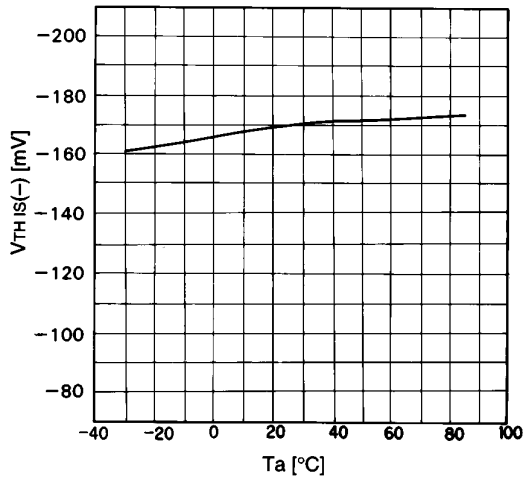

IS (+) terminal current (IIS(+)) vs. IS (+) terminal voltage (VIS(+))

FA5304AP(S)

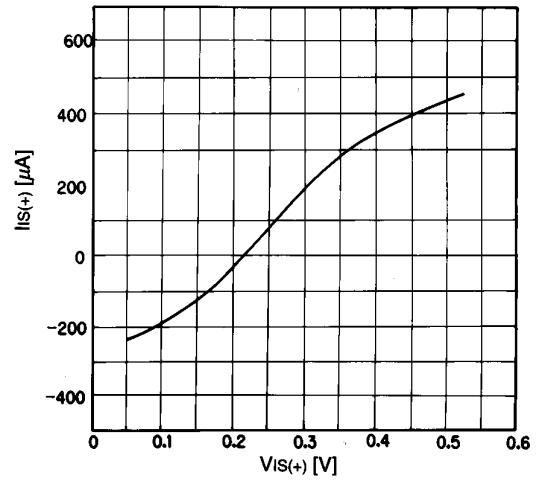

IS (-) terminal current (IIS(-)) vs. IS (-) terminal voltage (VIS(-))

FA5305AP(S)

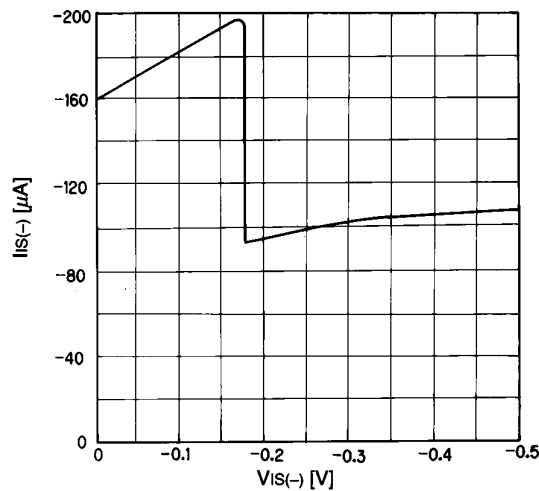

CS terminal sink current (ISINK CS) vs. CS terminal voltage (Vcs)

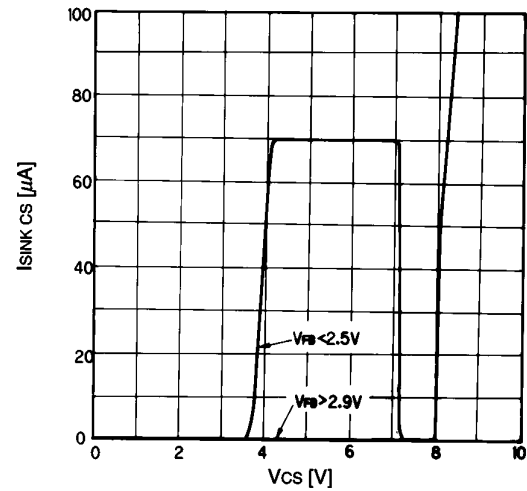

Error amplifier frequency (f) vs. voltage gain (Av) /phase (θ)

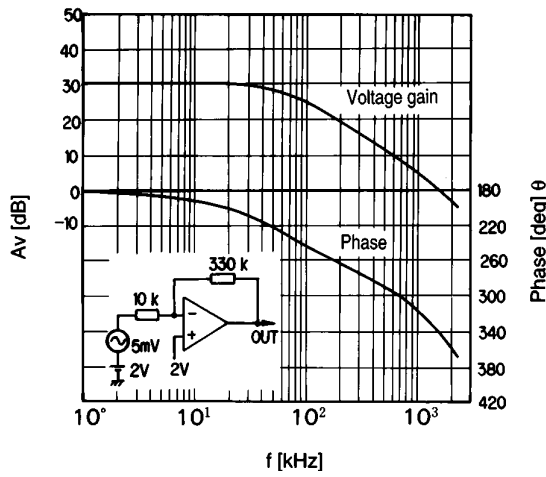

Supply current (Icc) vs. supply voltage (Vcc)  
Normal operation

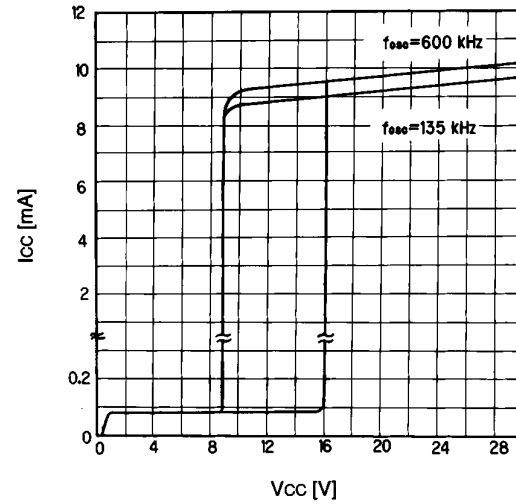

Supply current (Icc) vs. supply voltage (Vcc)  
OFF or OFF latch mode

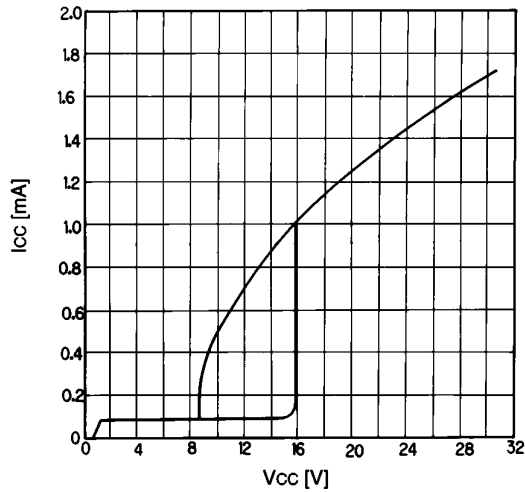



■ Application circuit

● Example of FA5304AP(S) application circuit (1)

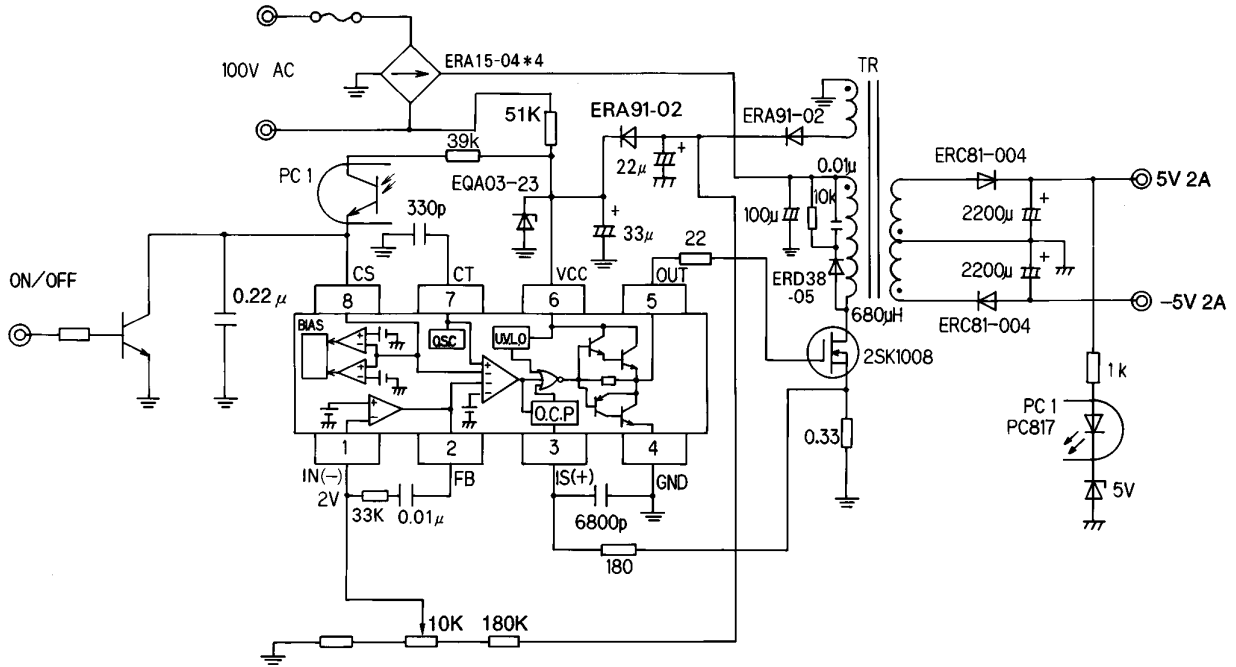

● Example of FA5304AP(S) application circuit (2)

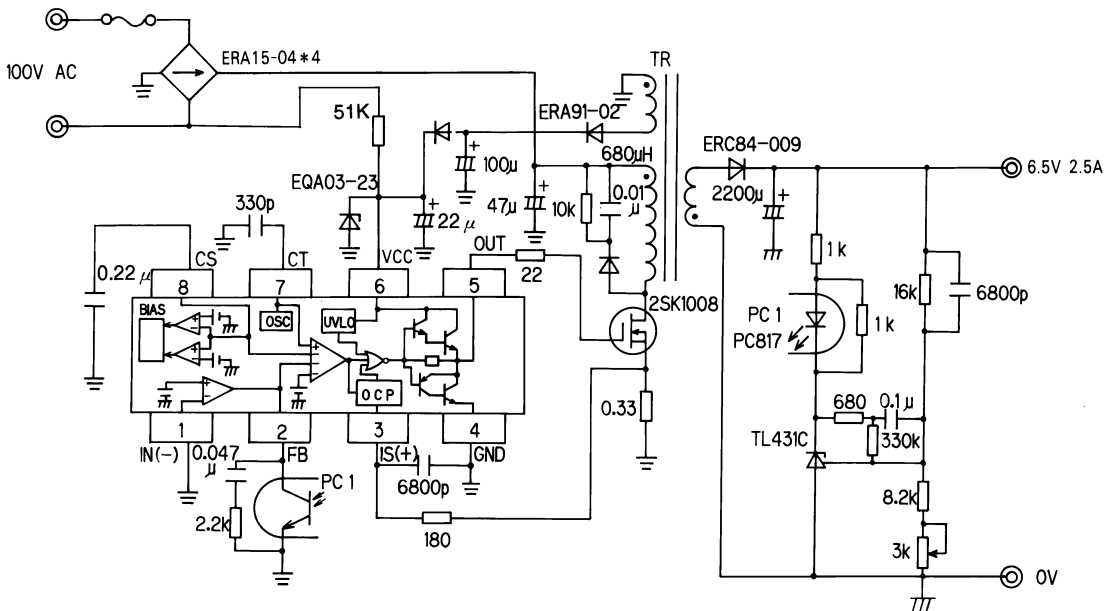

● Example of FA5304AP(S) application circuit (3)

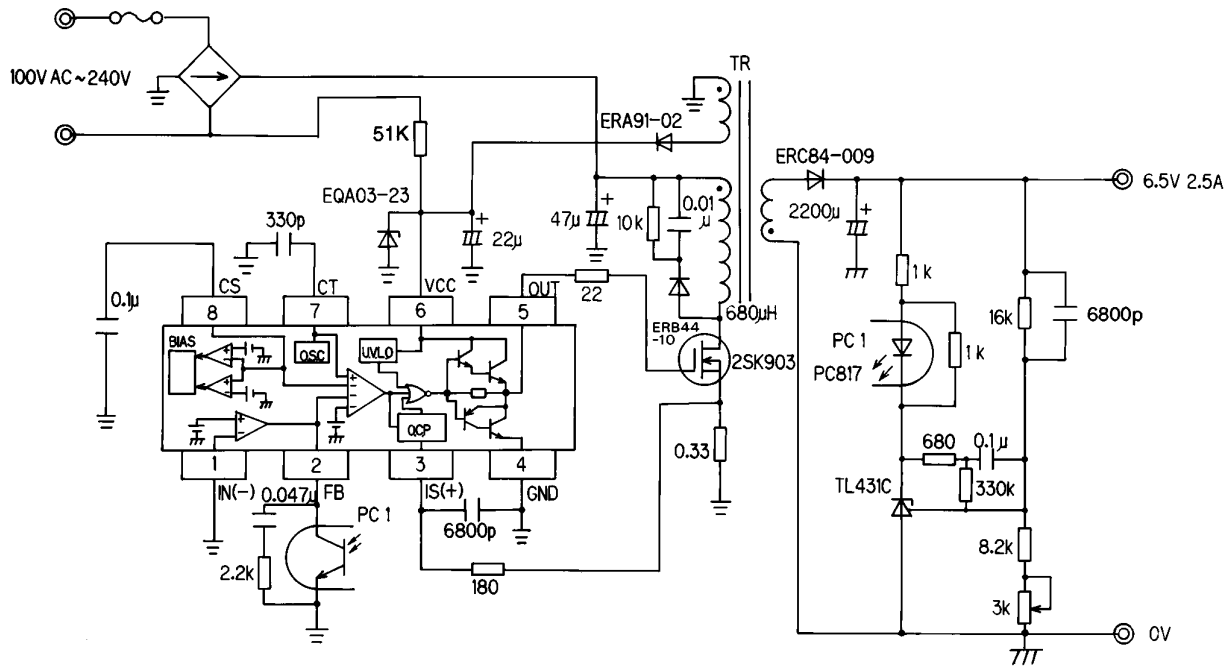

● Example of FA5305AP(S) application circuit

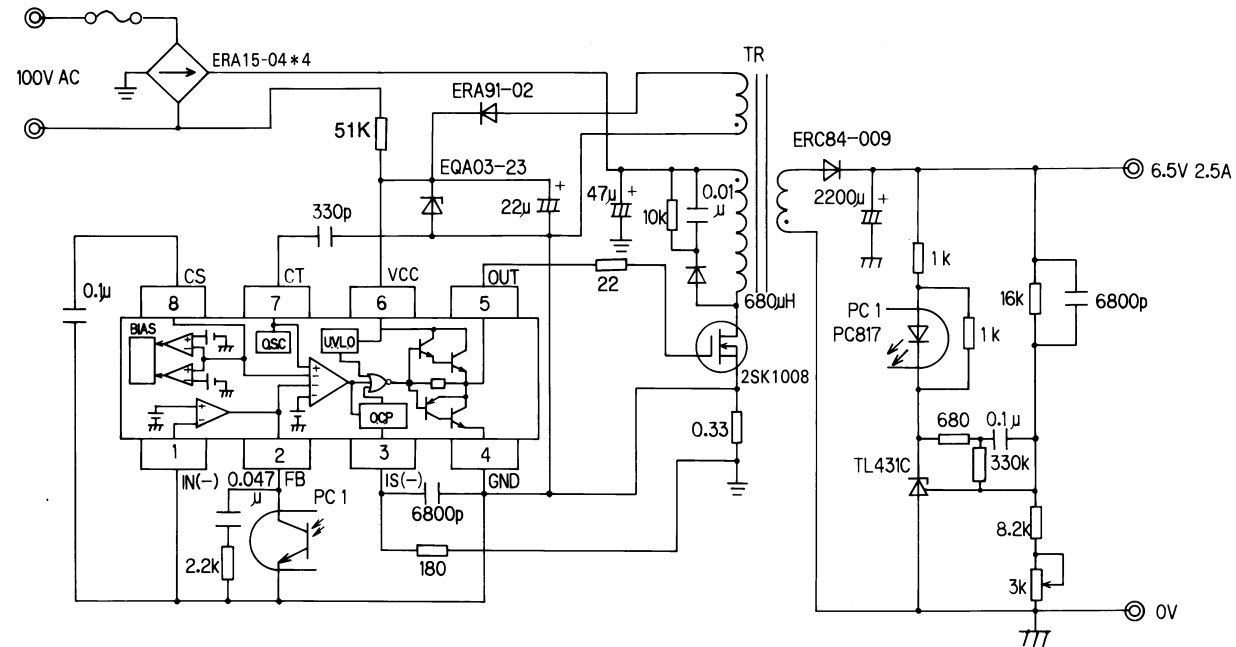

Parts tolerances characteristics are not defined in the circuit design sample shown above. When designing an actual circuit for a product, you must determine parts tolerances and characteristics for safe and economical operation.