

# MITSUBISHI RF POWER TRANSISTOR 2SC2166

## NPN EPITAXIAL PLANAR TYPE

### DESCRIPTION

2SC2166 is a silicon NPN epitaxial planar type transistor designed for RF power amplifiers in HF band mobile radio applications.

### FEATURES

- High power gain:  $G_{pe} \geq 13.8\text{dB}$   
@  $V_{CC} = 12\text{V}$ ,  $P_O = 6\text{W}$ ,  $f = 27\text{MHz}$
- Emitter ballasted construction for high reliability and good performances.
- TO-220 similar package is combinient for mounting.

### APPLICATION

3 to 4 watts output power amplifiers in HF band mobile radio applications.

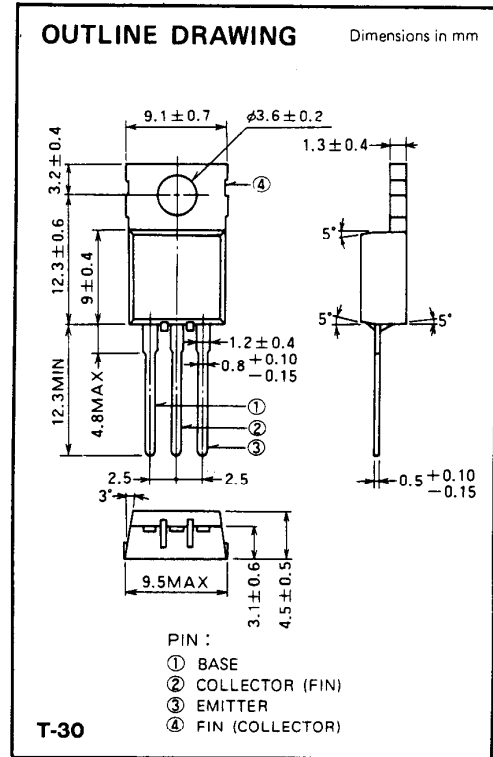

### ABSOLUTE MAXIMUM RATINGS ( $T_C = 25^\circ\text{C}$ unless otherwise specified)

Symbol	Parameter	Conditions	Ratings	Unit
$V_{CBO}$	Collector to base voltage		75	V
$V_{EBO}$	Emitter to base voltage		5	V
$V_{CER}$	Collector to emitter voltage	$R_{BE} = 10 \Omega$	75	V
$I_C$	Collector current		4	A
$P_C$	Collector dissipation	$T_a = 25^\circ\text{C}$	1.5	W
		$T_C = 25^\circ\text{C}$	12.5	W
$T_j$	Junction temperature		150	$^\circ\text{C}$
$T_{stg}$	Storage temperature		-55 to 150	$^\circ\text{C}$
$R_{th-a}$	Thermal resistance	Junction to ambient	83	$^\circ\text{C}/\text{W}$
$R_{th-c}$		Junction to case	10	$^\circ\text{C}/\text{W}$

Note. Above parameters are guaranteed independently.

### ELECTRICAL CHARACTERISTICS ( $T_C = 25^\circ\text{C}$ unless otherwise specified)

Symbol	Parameter	Test conditions	Limits			Unit
			Min	Typ	Max	
$V_{(BR)EBO}$	Emitter to base breakdown voltage	$I_E = 1\text{mA}$ , $I_C = 0$	5			V
$V_{(BR)CBO}$	Collector to base breakdown voltage	$I_C = 1\text{mA}$ , $I_E = 0$	75			V
$V_{(BR)CER}$	Collector to emitter breakdown voltage	$I_C = 10\text{mA}$ , $R_{BE} = 10 \Omega$	75			V
$I_{CBO}$	Collector cutoff current	$V_{CB} = 30\text{V}$ , $I_E = 0$			100	$\mu\text{A}$
$I_{EBO}$	Emitter cutoff current	$V_{EB} = 3\text{V}$ , $I_C = 0$			100	$\mu\text{A}$
$h_{FE}$	DC forward current gain *	$V_{CE} = 10\text{V}$ , $I_C = 0.1\text{A}$	35	70	180	—
$P_O$	Output power	$V_{CC} = 12\text{V}$ , $P_{in} = 0.25\text{W}$ , $f = 27\text{MHz}$	6	7.5		W
$\eta_C$	Collector efficiency		55	60		%

Note. \* Pulse test,  $P_W = 150\mu\text{s}$ , duty = 5%.

Above parameters, ratings, limits and conditions are subject to change.

NOV. '97



**NPN EPITAXIAL PLANAR TYPE**

**TEST CIRCUIT**

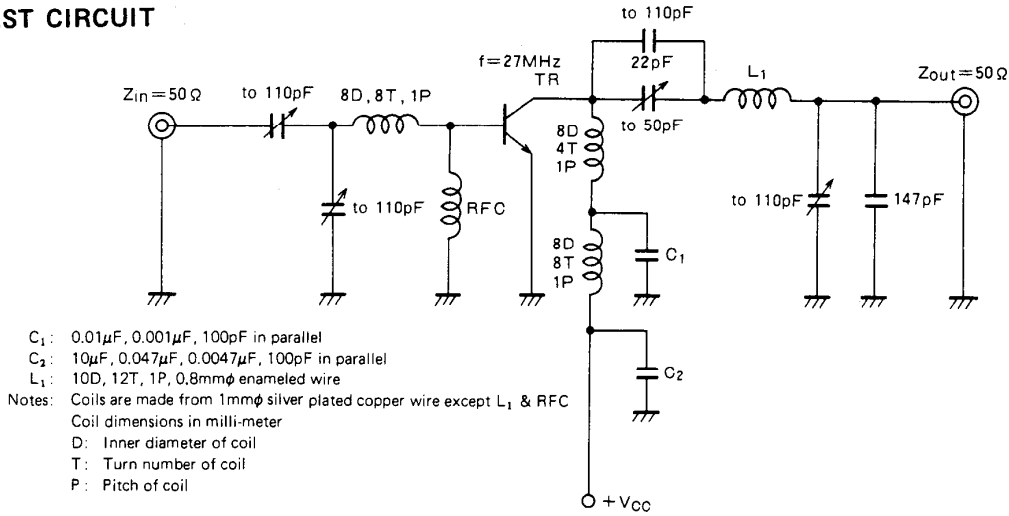

**TYPICAL PERFORMANCE DATA**

**COLLECTOR DISSIPATION VS. AMBIENT TEMPERATURE**

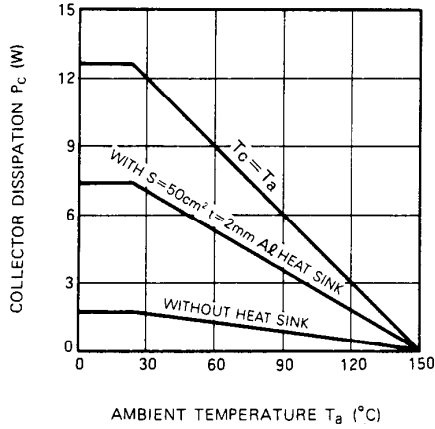

**COLLECTOR CURRENT VS. COLLECTOR TO EMITTER VOLTAGE**

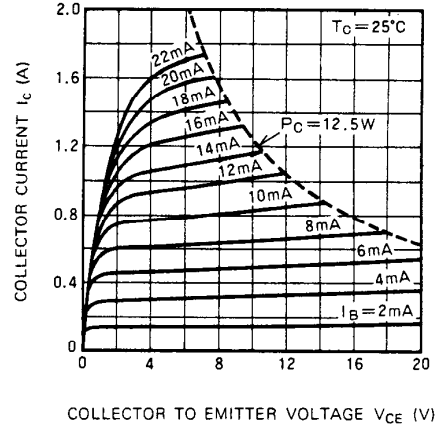

**DC CURRENT GAIN VS. COLLECTOR CURRENT**

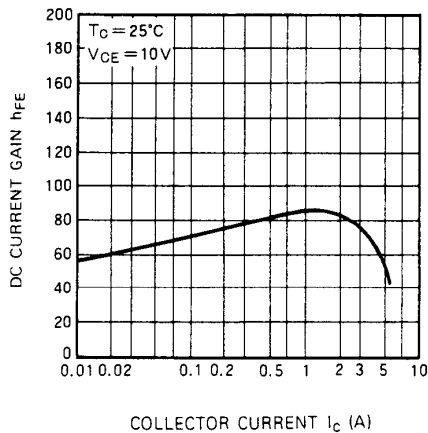

**COLLECTOR TO EMITTER BREAKDOWN VOLTAGE VS. BASE TO EMITTER RESISTANCE**

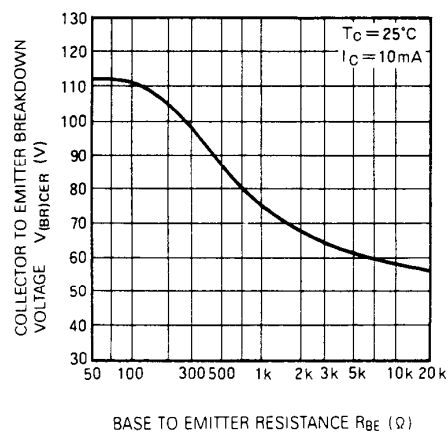

**NPN EPITAXIAL PLANAR TYPE**

**COLLECTOR OUTPUT CAPACITANCE VS. COLLECTOR TO BASE VOLTAGE**

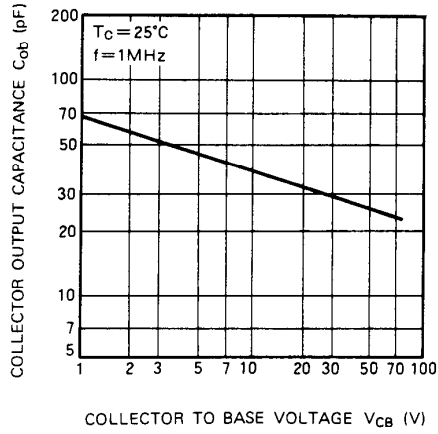

**OUTPUT POWER, COLLECTOR EFFICIENCY VS. INPUT POWER**

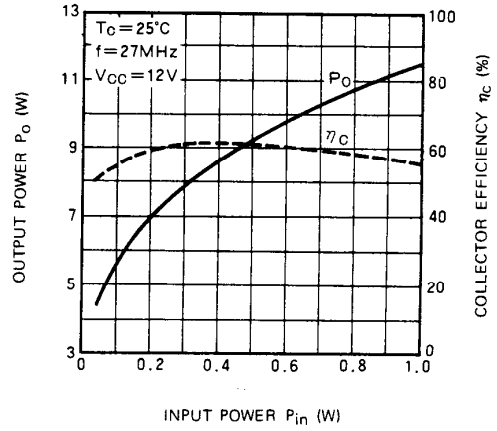

**OUTPUT POWER VS. COLLECTOR SUPPLY VOLTAGE**

