

UTC2SA1015 PNP EPITAXIAL SILICON TRANSISTOR

LOW FREQUENCY PNP AMPLIFIER TRANSISTOR

FEATURES

- *Collector-Emitter Voltage:
BVCEO=-50V
- *Collector current up to 150mA
- *High hFE linearity
- *Complement to 2SC1815

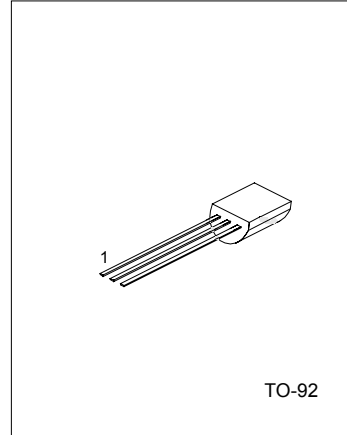

1:EMITTER 2:COLLECTOR 3: BASE

ABSOLUTE MAXIMUM RATINGS (Ta=25°C ,unless otherwise specified)

PARAMETER	SYMBOL	RATING	UNIT
Collector-base voltage	V _{CB0}	-50	V
Collector-emitter voltage	V _{CEO}	-50	V
Emitter-base voltage	V _{EBO}	-5	V
Collector dissipation	P _c	400	mW
Collector current	I _c	-150	mA
Base current	I _B	-50	mA
Junction Temperature	T _j	125	°C
Storage Temperature	T _{STG}	-65 ~ +150	°C

ELECTRICAL CHARACTERISTICS(Ta=25°C,unless otherwise specified)

PARAMETER	SYMBOL	TEST CONDITIONS	MIN	TYP	MAX	UNIT
Collector-base breakdown voltage	BV _{CB0}	I _c =-100μA, I _E =0	-50			V
Collector-emitter breakdown voltage	BV _{CEO}	I _c =-10mA, I _B =0	-50			V
Emitter-base breakdown voltage	BV _{EBO}	I _E =-10μA, I _c =0	-5			V
Collector cut-off current	I _{CBO}	V _{CB} =-50V, I _E =0			-100	nA
Emitter cut-off current	I _{EBO}	V _{EB} =-5V, I _c =0			-100	nA
DC current gain(note)	h _{FE1}	V _{CE} =-6V, I _c =-2mA	120		700	
	h _{FE2}	V _{CE} =-6V, I _c =-150mA	25			
Collector-emitter saturation voltage	V _{CE(sat)}	I _c =-100mA, I _B =-10mA		-0.1	-0.3	V
Base-emitter saturation voltage	V _{BE(sat)}	I _c =-100mA, I _B =-10mA			-1.1	V
Current gain bandwidth product	f _T	V _{CE} =-10V, I _c =-1mA	80			MHz
Output capacitance	C _{ob}	V _{CB} =-10V, I _E =0, f=1MHz		4.0	7.0	pF
Noise Figure	NF	I _c =-0.1mA, V _{CE} =-6V R _G =1kΩ, f=100Hz		0.5	6	dB

UTC UNISONIC TECHNOLOGIES CO. LTD

1

QW-R201-004,B

UTC2SA1015 PNP EPITAXIAL SILICON TRANSISTOR

CLASSIFICATION OF hFE1

RANK	Y	GR	BL
RANGE	120-240	200-400	350-700

TYPICAL CHARACTERISTIC CURVES

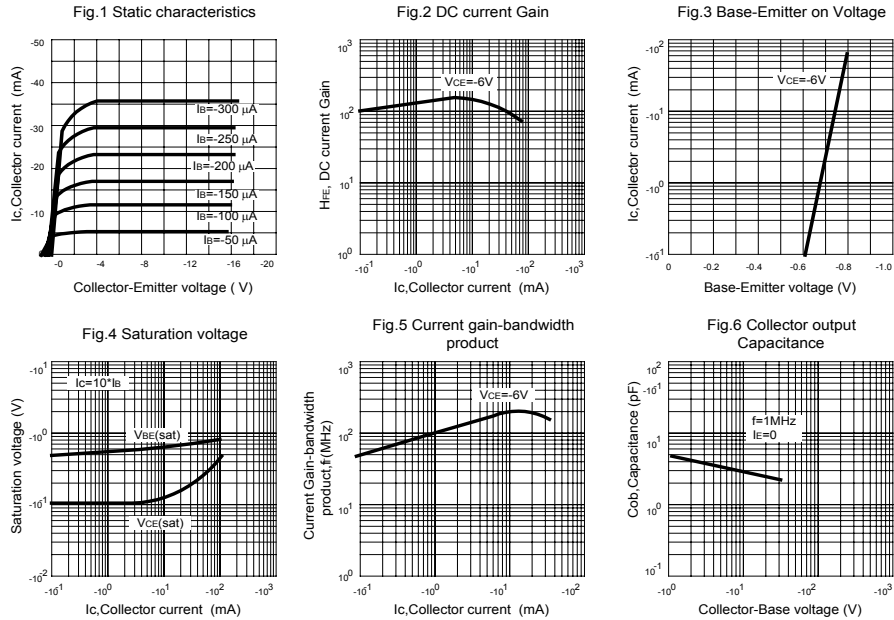

UTC assumes no responsibility for equipment failures that result from using products at values that exceed, even momentarily, rated values (such as maximum ratings, operating condition ranges, or other parameters) listed in products specifications of any and all UTC products described or contained herein. UTC products are not designed for use in life support appliances, devices or systems where malfunction of these products can be reasonably expected to result in personal injury. Reproduction in whole or in part is prohibited without the prior written consent of the copyright owner. The information presented in this document does not form part of any quotation or contract, is believed to be accurate and reliable and may be changed without notice.