

SPECIFICATIONS FOR NICHIA CHIP TYPE **GREEN** LED

MODEL : **NHSGC08T**

NICHIA CORPORATION

1.SPECIFICATIONS

(1) Absolute Maximum Ratings (Ta=25°C)

Item	Symbol	Absolute Maximum Rating	Unit
Forward Current	IF	20	mA
Pulse Forward Current	IFP	130	mA
Reverse Voltage	VR	5	V
Power Dissipation	PD	76	mW
Operating Temperature	Topr	-30 ~ +85	°C
Storage Temperature	Tstg	-40 ~ +100	°C
Soldering Temperature	Tsld	Reflow Soldering : 260°C for 10sec. Hand Soldering : 300°C for 3sec.	

IFP Conditions : Pulse Width ≤ 10msec. and Duty ≤ 1/10

(2) Initial Electrical/Optical Characteristics (Ta=25°C)

Item	Symbol	Condition	Min.	Max.	Unit
Forward Voltage	VF	IF=5 [mA]	2.7	3.4	V
Reverse Current	IR	VR= 5[V]	-	50	μA

* Forward Voltage Measurement allowance is ± 3%.

(3) Ranking (Ta=25°C)

Item	Symbol	Condition	Min.	Max.	Unit
Luminous Intensity	Rank P	IF=5[mA]	132	166	mcd
	Rank O		105	132	
	Rank N		83	105	

* Luminous Intensity Measurement allowance is ± 10%.

* Luminous intensity value is traceable to the CIE 127:2007-compliant national standards.

Color Ranks

(IF=5mA, Ta=25°C)

Rank G1p				
x	0.1830	0.1250	0.1760	0.2190
y	0.6250	0.7360	0.7500	0.6370

Rank G2r				
x	0.2190	0.1760	0.2328	0.2580
y	0.6370	0.7500	0.7418	0.6380

* Color Coordinates Measurement allowance is ± 0.02.

* Basically, a shipment shall consist of the LEDs of a combination of the above ranks.

The percentage of each rank in the shipment shall be determined by Nichia.

2.INITIAL OPTICAL/ELECTRICAL CHARACTERISTICS

Please refer to “CHARACTERISTICS” on the following page.

3.OUTLINE DIMENSIONS AND MATERIALS

Please refer to “OUTLINE DIMENSIONS” on the following page.

4.PACKAGING

- The LEDs are packed in cardboard boxes after taping.
Please refer to “TAPING DIMENSIONS” and “PACKING ”on the following pages.
The label on the minimum packing unit shows ; Part Number, Lot Number, Ranking, Quantity
- In order to protect the LEDs from mechanical shock, we pack them in cardboard boxes for transportation.
- The LEDs may be damaged if the boxes are dropped or receive a strong impact against them,
so precautions must be taken to prevent any damage.
- The boxes are not water resistant and therefore must be kept away from water and moisture.
- When the LEDs are transported, we recommend that you use the same packing method as Nichia.

5.LOT NUMBER

The first six digits number shows **lot number**.

The lot number is composed of the following characters;

○□×××× - ◇◇◇

○ - Year (8 for 2008, 9 for 2009)

□ - Month (1 for Jan., 9 for Sep., A for Oct., B for Nov.)

×××× - Nichia's Product Number

◇◇◇ - Ranking

6.RELIABILITY

(1) TEST ITEMS AND RESULTS

Test Item	Standard Test Method	Test Conditions	Note
Resistance to Soldering Heat (Reflow Soldering)	JEITA ED-4701 300 301	Tsld=260°C, 10sec. (Pre treatment 30°C, 70%,168hrs.)	2 times
Solderability (Reflow Soldering)	JEITA ED-4701 300 303A	Tsld=215 ± 5°C, 3sec. (Lead Solder)	1 time over 95%
Thermal Shock	JEITA ED-4701 300 307	0°C ~ 100°C 5sec. 15sec.	20 cycles
Temperature Cycle	JEITA ED-4701 100 105	-30°C ~ 25°C ~ 100°C ~ 25°C 15min. 5min. 15min. 5min.	100 cycles
Moisture Resistance Cyclic	JEITA ED-4701 200 203	30°C ~ 65°C ~ -10°C 90%RH 24hrs./1cycle	10 cycles
High Temperature Storage	JEITA ED-4701 200 201	Ta=100°C	1000 hrs.
Temperature Humidity Storage	JEITA ED-4701 100 103	Ta=60°C, RH=90%	1000 hrs.
Low Temperature Storage	JEITA ED-4701 200 202	Ta=-40°C	1000 hrs.
Steady State Operating Life		Ta=25°C, IF=20mA	1000 hrs.
Steady State Operating Life of High Temperature		Ta=85°C, IF=5mA	1000 hrs.
Steady State Operating Life of High Humidity Heat		60°C, RH=90%, IF=13mA	500 hrs.
Steady State Operating Life of Low Temperature		Ta=-30°C, IF=20mA	1000 hrs.
Vibration		10 - 500Hz, 15min., Total amplitude 1.5mm or 10G	6 hrs.
Substrate Bending	JEITA ED-4702	3mm, 5 ± 1 sec.	1 time
Adhesion Strength	JEITA ED-4702	5N, 10 ± 1 sec.	1 time
Shock	JEITA ED-4701 400 404	1500G, 0.5ms, X,Y,Z direction three times for each	2 cycles

(2) CRITERIA FOR JUDGING DAMAGE

Item	Symbol	Test Conditions	Criteria for Judgement	
			Min.	Max.
Forward Voltage	V _F	I _F =5mA	-	U*) × 1.1
Reverse Current	I _R	V _R =5V	-	U*) × 2.0
Luminous Intensity	I _V	I _F =5mA	S**) × 0.5	-

*) U : Upper limit of the specified characteristics

**) S : The initial value

7. CAUTIONS

(1) Moisture Proof Package

- To prevent moisture absorption during transportation and storage, reels are packed in aluminum envelopes that contain a desiccant with a humidity indicator.

(2) Storage

- To prevent moisture absorption, it is strongly recommended that reels (in bulk or taped) should be stored in the dry box (or the desiccator) with a desiccant as the appropriate storage place.

If not, the following is recommended.

Temperature : 5 ~ 30 °C

Humidity : 60%RH Max.

The devices should be mounted as soon as possible after unpacking. If you store the unpacked reels, please store them in the dry box or seal them into the envelope again.

- If the devices have been stored over 6 months or unpacked over 15 days, it should be baked under the following conditions.

Baking conditions : 60°C × 12 hours or more (reeled one)

120°C × 45 minutes or more (loose one)

150°C × 15 minutes or more (loose one)

- Nichia LED electrodes are gold plated. The gold surface may be affected by environments which contain corrosive substances. Please avoid conditions which may cause the LED to corrode, tarnish or discolor. This corrosion or discoloration may cause difficulty during soldering operations. It is recommended that the customer use the LEDs as soon as possible.
- Please avoid rapid transitions in ambient temperature, especially in high humidity environments where condensation can occur.

(3) Recommended circuit

- In designing a circuit, the current through each LED must not exceed the absolute maximum rating specified for each LED. It is recommended to use Circuit B which regulates the current flowing through each LED. In the meanwhile, when driving LEDs with a constant voltage in Circuit A, the current through the LEDs may vary due to the variation in forward voltage (V_F) of the LEDs. In the worst case, some LED may be subjected to stresses in excess of the absolute maximum rating.

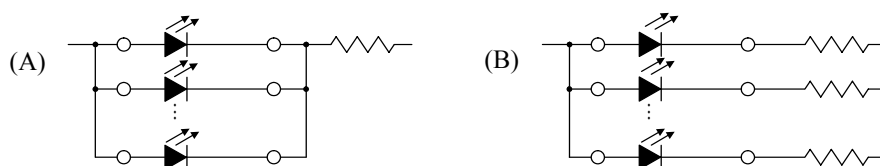

- This product should be operated in forward bias. A driving circuit must be designed so that the product is not subjected to either forward or reverse voltage while it is off. In particular, if a reverse voltage is continuously applied to the product, such operation can cause migration resulting in LED damage.

(4) Heat Generation

- Thermal design of the end product is of paramount importance. Please consider the heat generation of the LED when making the system design. The coefficient of temperature increase per input electric power is affected by the thermal resistance of the circuit board and density of LED placement on the board, as well as other components. It is necessary to avoid intense heat generation and operate within the maximum ratings given in this specification.
- The operating current should be decided after considering the ambient maximum temperature of LEDs.

(5) Soldering Conditions

- The LEDs can be soldered in place using the reflow soldering method. Nichia cannot make a guarantee on the LEDs after they have been assembled using the dip soldering method.
- Recommended soldering conditions

Reflow Soldering		Hand Soldering	
	Lead-free Solder		
Pre-heat	160 ~ 180°C	Soldering Iron	25W Max.
Pre-heat time	140 sec. Max.	Temperature	300°C Max.
Peak temperature	260°C Max.	Soldering time	3 sec. Max.
Soldering time	10 sec. Max.		(one time only)
Condition	refer to Temperature - profile.	Soldering paste composition	96.5Sn 3Ag 0.5Cu
Recommended soldering paste			
Melting temperature	216 ~ 220°C		
composition	96.5Sn 3Ag 0.5Cu		

- * Although the recommended soldering conditions are specified in the above table, reflow or hand soldering at the lowest possible temperature is desirable for the LEDs.
- * A rapid-rate process is not recommended for cooling the LEDs down from the peak temperature.

[Temperature-profile (the top surface of the parts)]

Use the conditions shown to the under figure.

< Lead-free Solder >

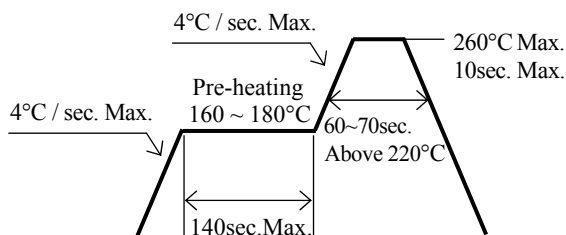

[Recommended soldering pad design]

The following dimensions do not guarantee the performance of mountability.

Use the following pattern after deep study.

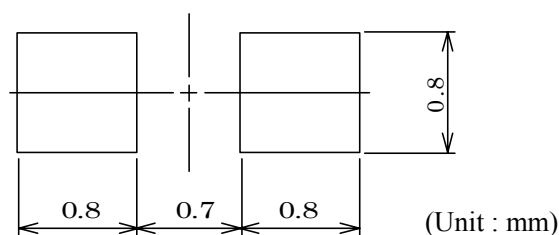

- Repairing should not be done after the LEDs have been soldered. When repairing is unavoidable, a double-head soldering iron should be used. It should be confirmed beforehand whether the characteristics of the LEDs will or will not be damaged by repairing.
- Reflow soldering should not be done more than two times.
- Before soldering every time, make baking to units. By manual soldering, there is possibility of crack due to the moisture absorption in the resin portion.
- When soldering, do not put stress on the LEDs during heating.
- After soldering, do not warp the circuit board.
- Handle the devices only after temperature is cooled down.

(6) Washing

- When washing after soldering is needed, following conditions are requested.
 - a) Washing solvent: Ak – 225 Alcohol
 - b) Temperature and time: 50°C or less × 30 seconds Max, or 30°C or less × 3 minutes Max.
 - c) Ultrasonic washing: Basically Not accepted.

(7) Static Electricity

- Static electricity or surge voltage damages the LEDs.
It is recommended that a wrist band or an anti-electrostatic glove be used when handling the LEDs.
- All devices, equipment and machinery must be properly grounded. It is recommended that precautions be taken against surge voltage to the equipment that mounts the LEDs.
- When inspecting the final products in which LEDs were assembled, it is recommended to check whether the assembled LEDs are damaged by static electricity or not. It is easy to find static-damaged LEDs by a light-on test or a VF test at a lower current (below 1mA is recommended).
- Damaged LEDs will show some unusual characteristics such as the leak current remarkably increases, the forward voltage becomes lower, or the LEDs do not light at the low current.

(8) Safety Guideline for Human Eyes

- The International Electrical Commission (IEC) published in 2006 IEC 62471:2006 *Photobiological safety of lamps and lamp systems* which includes LEDs within its scope. Meanwhile LEDs were removed from the scope of the IEC 60825-1:2007 laser safety standard, the 2001 edition of which included LED sources within its scope. However, keep in mind that some countries and regions have adopted standards based on the IEC laser safety standard IEC 60825-1:2001 which includes LEDs within its scope.

Following IEC 62471:2006, most of Nichia LEDs can be classified as belonging to either Exempt Group or Risk Group 1. Optical characteristics of a LED such as radiant flux, spectrum and light distribution are factors that affect the risk group determination of the LED. Especially a high-power LED, that emits light containing blue wavelengths, may be in Risk Group 2.

Great care should be taken when viewing directly the LED driven at high current or the LED with optical instruments, which may greatly increase the hazard to your eyes.

(9) Others

- NHSGC08 complies with RoHS Directive.
- It is requested to avoid any stress added to the resin portion while it is heated.
- It is requested to avoid any friction by sharp metal nail etc, to the resin portion.
- The current limiting resistor should be placed in the circuit in order for LED to work within its rating. Also avoid reverse voltage (overcurrent) applied instantaneously when ON or OFF.
- When assembling the circuit board into the finished products, care must be taken to avoid the component parts from touching other parts.
- Flashing lights have been known to cause discomfort in people; you can prevent this by taking precautions during use. Also, people should be cautious when using equipment that has had LEDs incorporated into it.
- The LEDs described in this brochure are intended to be used for ordinary electronic equipment (such as office equipment, communications equipment, measurement instruments and household appliances). Consult Nichia's sales staff in advance for information on the applications in which exceptional quality and reliability are required, particularly when the failure or malfunction of the LEDs may directly jeopardize life or health (such as for airplanes, aerospace, submersible repeaters, nuclear reactor control systems, automobiles, traffic control equipment, life support systems and safety devices).
- The customer shall not reverse engineer by disassembling or analysis of the LEDs without having prior written consent from Nichia. When defective LEDs are found, the customer shall inform Nichia directly before disassembling or analysis.
- The formal specifications must be exchanged and signed by both parties before large volume purchase begins.
- The appearance and specifications of the product may be modified for improvement without notice.

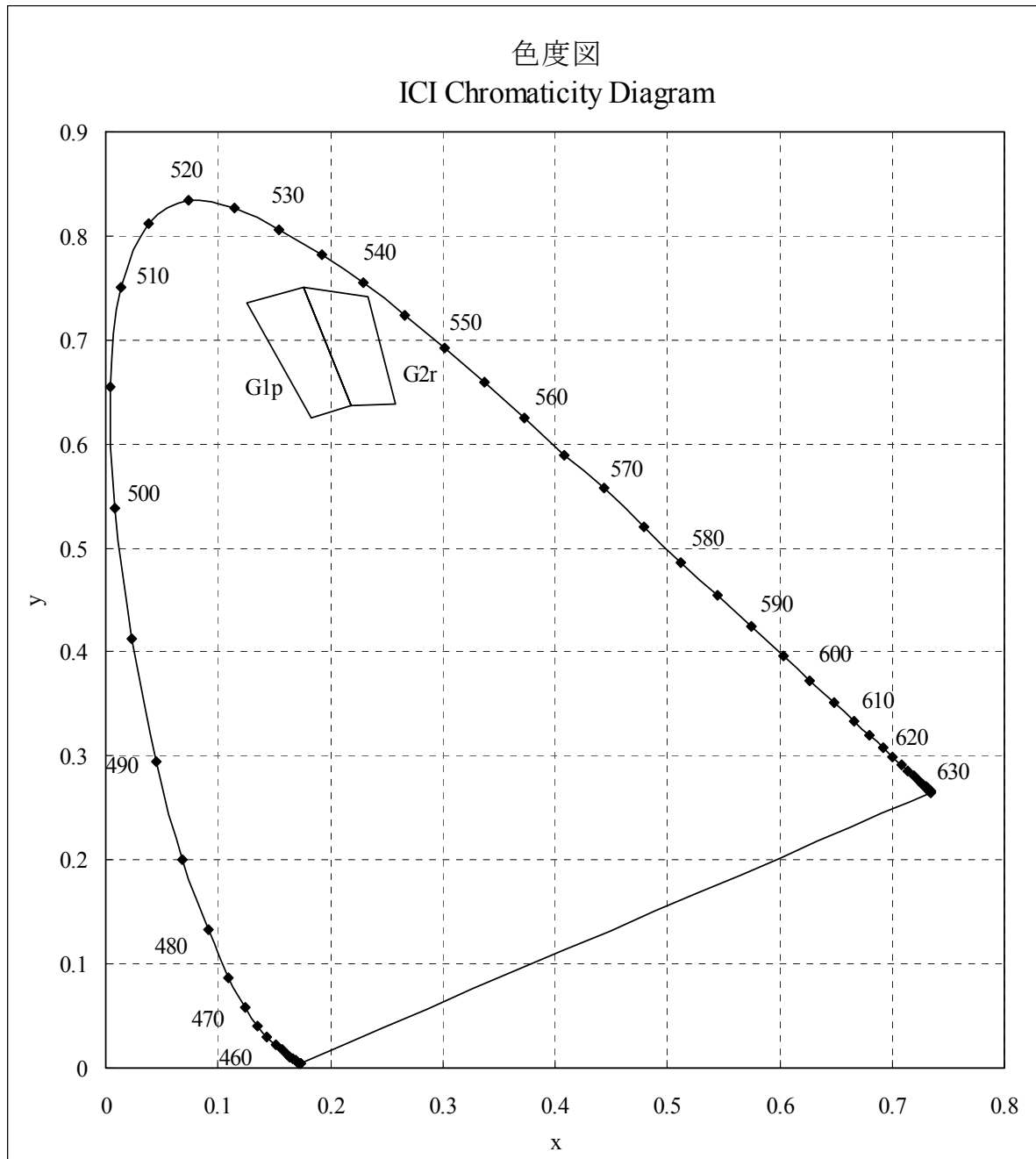

* Color Coordinates Measurement allowance is ± 0.02 .

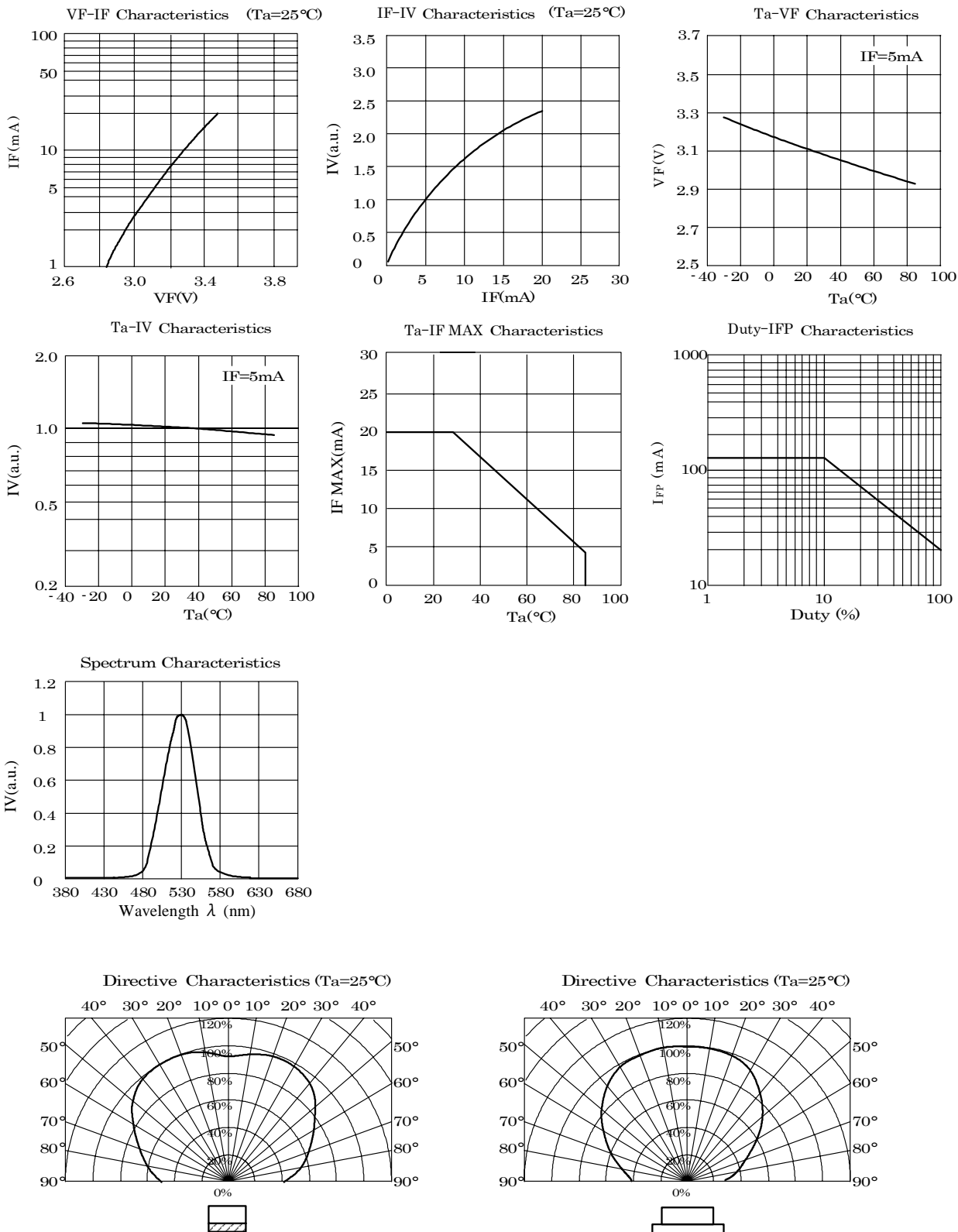

型名 Model NHSGC08	名称 Title 初期電気/光学特性 CHARACTERISTICS
日亜化学工業 (株) NICHIA CORPORATION	管理番号 No. 081227834061

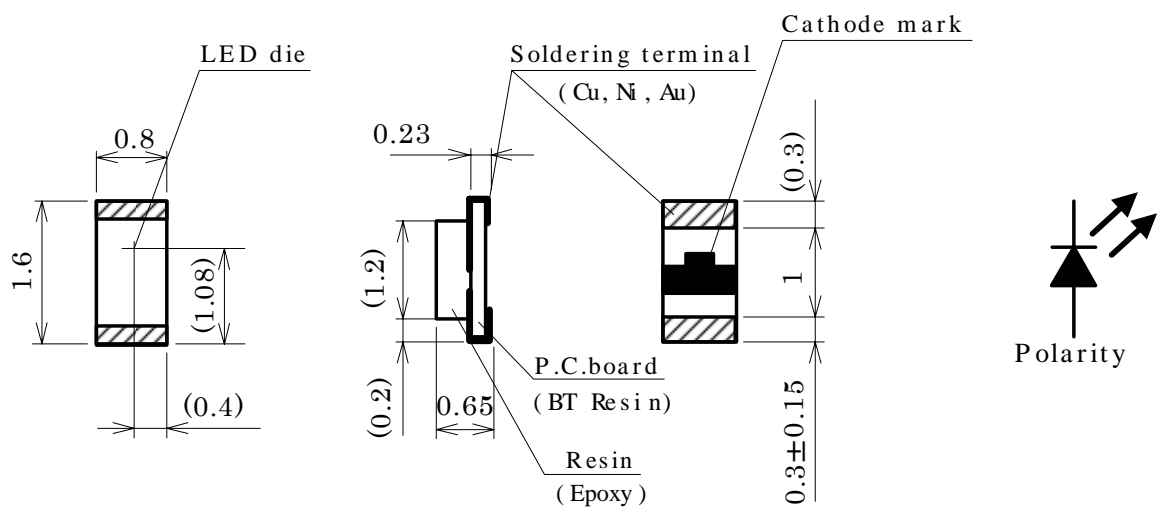

型名 Model NHSxC08	名称 Title 外形寸法図 OUTLINE DIMENSIONS	単位 Unit mm
日亜化学工業 (株) NICHIA CORPORATION	管理番号 No. 090507941461	公差 Allow ±0.1

Reel part

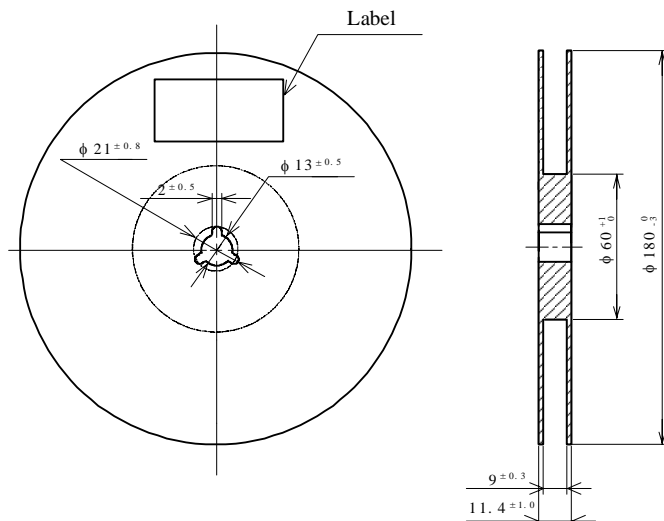

Taping part

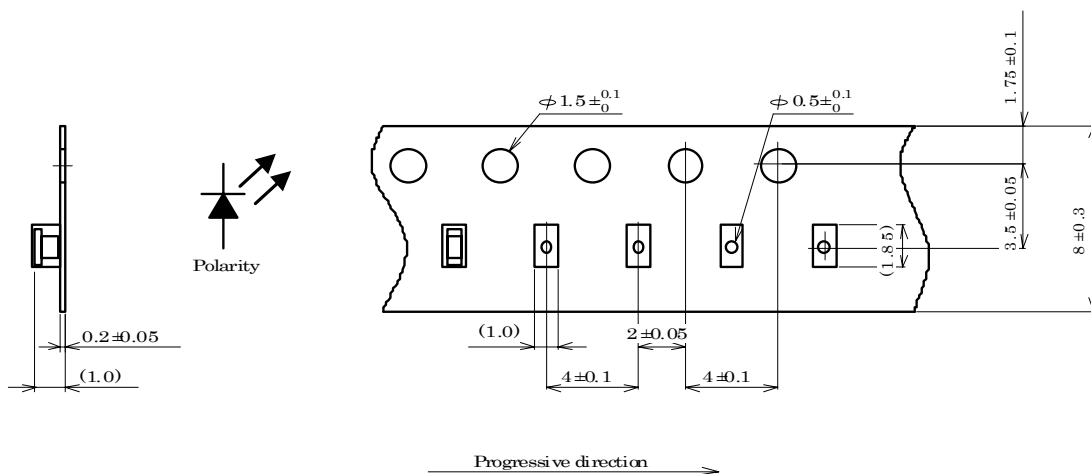

Reel End of tape

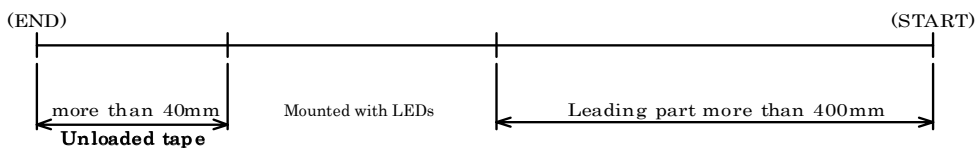

5,000pcs/Reel

Taping is based on the **JIS C 0806** : Packaging of Electronic Components on Continuous Tapes.

Peel Strength is based on the **JIS C 0806 - 1995**.

型名 Model NHSxC08T	名称 テーピング仕様図 Title TAPING DIMENSIONS	単位 Unit mm
日亜化学工業 (株) NICHIA CORPORATION	管理番号 No. 081227834031	

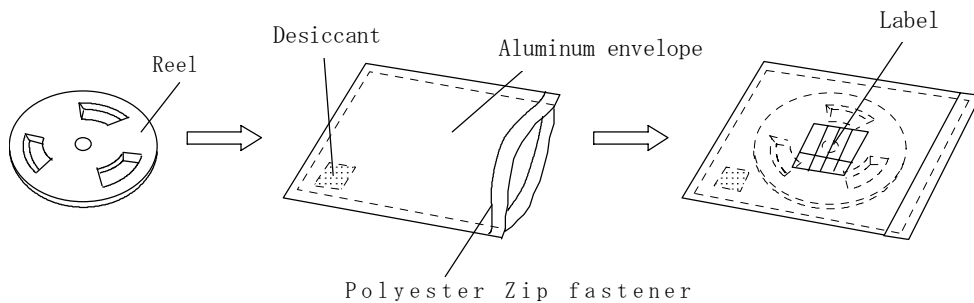

The box is partitioned with the cardboard.

Label

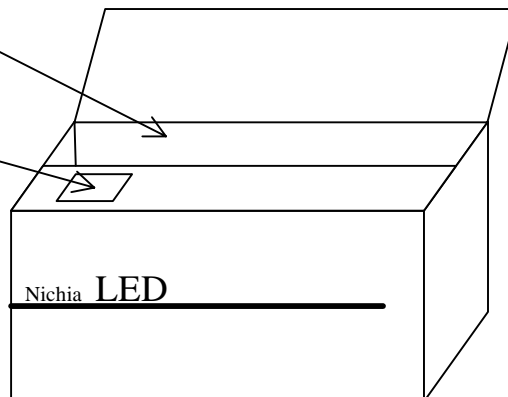
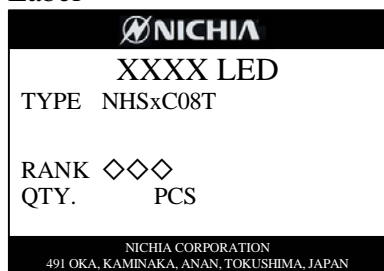

	Reel/ bag	Quantity/bag(pcs)
Moisture proof foil bag	1reel	5,000MAX

Cardbord box	Dimensions(mm)	Reel/box	Quantity/bag(pcs)
S	291 × 237 × 120 × 8t	7reel MAX.	35,000 MAX.
M	259 × 247 × 243 × 5t	15reel MAX.	75,000 MAX.
L	444 × 262 × 259 × 8t	30reel MAX.	150,000 MAX.

型名 Model NHSxC08T	名称 Title 梱包仕様図 PACKING
日亜化学工業 (株) NICHIA CORPORATION	管理番号 No. 081227834041