

## Smart Sense High-Side Power Switch

### Features

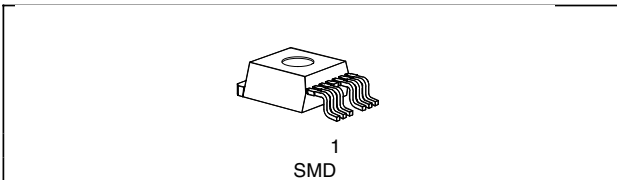
- Short circuit protection
- Current limitation
- Proportional load current sense
- CMOS compatible input
- Open drain diagnostic output
- Fast demagnetization of inductive loads
- Undervoltage and overvoltage shutdown with auto-restart and hysteresis
- Overload protection
- Thermal shutdown
- Overvoltage protection including load dump (with external GND-resistor)
- Reverse battery protection (with external GND-resistor)
- Loss of ground and loss of  $V_{bb}$  protection
- Electrostatic discharge (ESD) protection



### Product Summary

Operating voltage	$V_{bb(ON)}$	5.0 ... 34	V
On-state resistance	$R_{ON}$	30	mΩ
Load current (ISO)	$I_{L(ISO)}$	12.6	A
Current limitation	$I_{L(SCr)}$	24	A

### Package



- AEC qualified
- Green product (RoHS compliant)

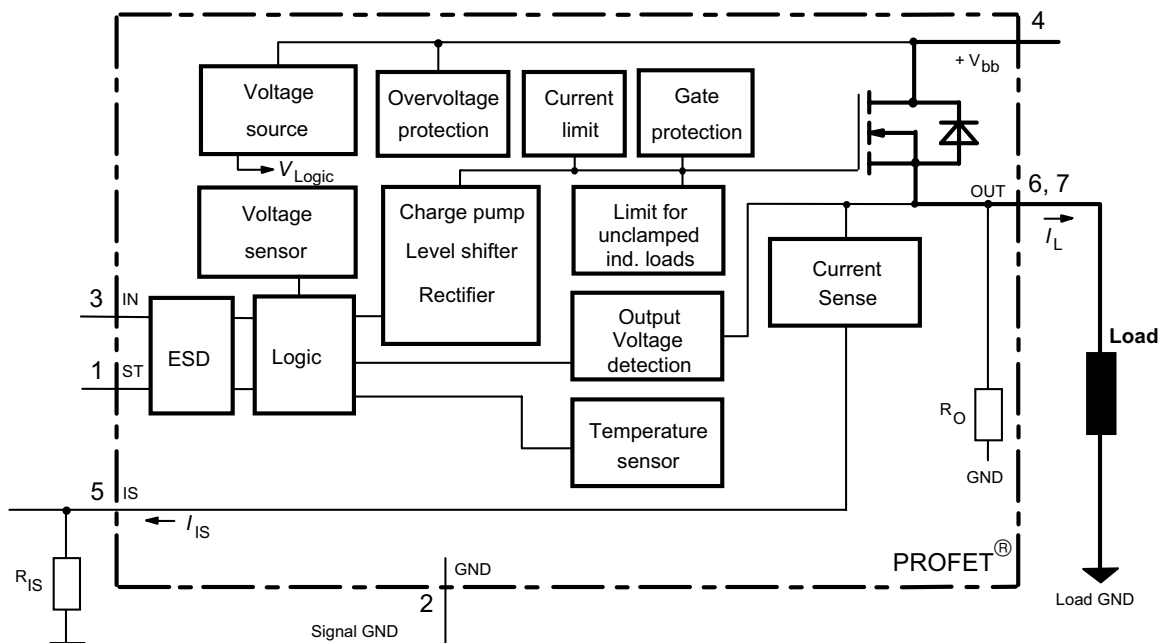
### Application

- $\mu$ C compatible power switch with diagnostic feedback for 12 V and 24 V DC grounded loads
- All types of resistive, inductive and capacitive loads
- Replaces electromechanical relays, fuses and discrete circuits

### General Description

N channel vertical power FET with charge pump, ground referenced CMOS compatible input and diagnostic feedback, proportional sense of load current, monolithically integrated in Smart SiPMOS® technology. Providing embedded protective functions.

### Block Diagram



Pin	Symbol	Function
1	ST	Diagnostic feedback: open drain, invers to input level
2	GND	Logic ground
3	IN	Input, activates the power switch in case of logical high signal
4	V <sub>bb</sub>	Positive power supply voltage, the tab is shorted to this pin
5	IS	Sense current output, proportional to the load current, zero in the case of current limitation of load current
6 & 7	OUT (Load, L)	Output, protected high-side power output to the load. Both output pins have to be connected in parallel for operation according this spec (e.g. $k_{ILIS}$ ). Design the wiring for the max. short circuit current

**Maximum Ratings** at  $T_j = 25\text{ °C}$  unless otherwise specified

Parameter	Symbol	Values	Unit
Supply voltage (overvoltage protection see page 4)	$V_{bb}$	43	V
Supply voltage for full short circuit protection $T_j \text{ Start} = -40 \dots +150\text{ °C}$	$V_{bb}$	34	V
Load dump protection <sup>1)</sup> $V_{LoadDump} = V_A + V_S$ , $V_A = 13.5\text{V}$ $R_I^{(2)} = 2\ \Omega$ , $R_L = 1\ \Omega$ , $t_d = 200\text{ ms}$ , IN= low or high	$V_{Load\ dump}^{(3)}$	60	V
Load current (Short circuit current, see page 5)	$I_L$	self-limited	A
Operating temperature range	$T_j$	-40 ... +150	°C
Storage temperature range	$T_{stg}$	-55 ... +150	
Power dissipation (DC), $T_C \leq 25\text{ °C}$	$P_{tot}$	85	W
Inductive load switch-off energy dissipation, single pulse $V_{bb} = 12\text{V}$ , $T_{j,start} = 150\text{ °C}$ , $T_C = 150\text{ °C}$ const. $I_L = 12.6\text{ A}$ , $Z_L = 4,2\text{ mH}$ , $0\ \Omega$ : $I_L = 4\text{ A}$ , $Z_L = 330\text{ mH}$ , $0\ \Omega$ :	$E_{AS}$ $E_{AS}$	0,41 3,5	J
Electrostatic discharge capability (ESD) (Human Body Model) IN: ST, IS: out to all other pins shorted: acc. MIL-STD883D, method 3015.7 and ESD assn. std. S5.1-1993 R=1.5k $\Omega$ ; C=100pF	$V_{ESD}$	1.0 4.0 8.0	kV
Input voltage (DC)	$V_{IN}$	-10 ... +16	V
Current through input pin (DC)	$I_{IN}$	$\pm 2.0$	mA
Current through status pin (DC)	$I_{ST}$	$\pm 5.0$	
Current through current sense pin (DC) see internal circuit diagrams page 8	$I_{IS}$	$\pm 14$	

- 1) Supply voltages higher than  $V_{bb(AZ)}$  require an external current limit for the GND and status pins (a 150  $\Omega$  resistor in the GND connection is recommended).
- 2)  $R_I$  = internal resistance of the load dump test pulse generator
- 3)  $V_{Load\ dump}$  is setup without the DUT connected to the generator according to ISO 7637-1 and DIN 40839

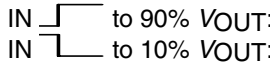
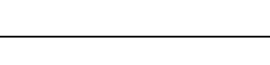
### Thermal Characteristics

Parameter and Conditions	Symbol	Values			Unit
		min	typ	max	
Thermal resistance chip - case:	$R_{thJC}$	--	--	1.47	K/W
junction - ambient (free air):	$R_{thJA}$	--	--	75	
SMD version, device on PCB <sup>4)</sup> :		--	33	--	

### Electrical Characteristics

Parameter and Conditions at $T_j = 25^\circ\text{C}$ , $V_{bb} = 12\text{ V}$ unless otherwise specified	Symbol	Values			Unit
		min	typ	max	

### Load Switching Capabilities and Characteristics

On-state resistance (pin 4 to 6&7) $I_L = 5\text{ A}$	$T_j = 25^\circ\text{C}$ : $T_j = 150^\circ\text{C}$ :	$R_{ON}$	--	27 54	30 60	m $\Omega$
Output voltage drop limitation at small load currents (pin 4 to 6&7), see page 14 $I_L = 0.5\text{ A}$	$T_j = -40\dots+150^\circ\text{C}$ :	$V_{ON(NL)}$	--	50	--	mV
Nominal load current, ISO Norm (pin 4 to 6&7) $V_{ON} = 0.5\text{ V}$ , $T_C = 85^\circ\text{C}$		$I_{L(ISO)}$	11.4	12.6	--	A
Nominal load current, device on PCB <sup>4)</sup> $T_A = 85^\circ\text{C}$ , $T_j \leq 150^\circ\text{C}$ $V_{ON} \leq 0.5\text{ V}$ ,		$I_{L(NOM)}$	4.0	4.5	--	A
Output current (pin 6&7) while GND disconnected or GND pulled up, $V_{bb} = 30\text{ V}$ , $V_{IN} = 0$ , see diagram page 9; not subject to production test, specified by design		$I_{L(GNDhigh)}$	--	--	8	mA
Turn-on time Turn-off time $R_L = 12\ \Omega$ , $T_j = -40\dots+150^\circ\text{C}$	IN  to 90% $V_{OUT}$ : IN  to 10% $V_{OUT}$ :	$t_{on}$ $t_{off}$	25 25	70 80	150 200	$\mu\text{s}$
Slew rate on 10 to 30% $V_{OUT}$ , $R_L = 12\ \Omega$ , $T_j = -40\dots+150^\circ\text{C}$		$dV/dt_{on}$	0.1	--	1	V/ $\mu\text{s}$
Slew rate off 70 to 40% $V_{OUT}$ , $R_L = 12\ \Omega$ , $T_j = -40\dots+150^\circ\text{C}$		$-dV/dt_{off}$	0.1	--	1	V/ $\mu\text{s}$

<sup>4)</sup> Device on 50mm\*50mm\*1.5mm epoxy PCB FR4 with 6cm<sup>2</sup> (one layer, 70 $\mu\text{m}$  thick) copper area for  $V_{bb}$  connection. PCB is vertical without blown air.

Parameter and Conditions at $T_j = 25^\circ\text{C}$ , $V_{bb} = 12\text{ V}$ unless otherwise specified	Symbol	Values			Unit
		min	typ	max	
<b>Operating Parameters</b>					
Operating voltage <sup>5)</sup>	$T_j = -40\dots+150^\circ\text{C}$ : $V_{bb(\text{on})}$	5.0	--	34	V
Undervoltage shutdown	$T_j = -40\dots+150^\circ\text{C}$ : $V_{bb(\text{under})}$	3.2	--	5.0	V
Undervoltage restart	$T_j = -40\dots+25^\circ\text{C}$ : $V_{bb(\text{u rst})}$ $T_j = +150^\circ\text{C}$ :	--	4.5	5.5 6.0	V
Undervoltage restart of charge pump see diagram page 13	$T_j = -40\dots+25^\circ\text{C}$ : $V_{bb(\text{ucp})}$ $T_j = 25\dots150^\circ\text{C}$ :	--	4.7 --	6.5 7.0	V
Undervoltage hysteresis $\Delta V_{bb(\text{under})} = V_{bb(\text{u rst})} - V_{bb(\text{under})}$	$\Delta V_{bb(\text{under})}$	--	0.5	--	V
Overvoltage shutdown	$T_j = -40\dots+150^\circ\text{C}$ : $V_{bb(\text{over})}$	34	--	43	V
Overvoltage restart	$T_j = -40\dots+150^\circ\text{C}$ : $V_{bb(\text{o rst})}$	33	--	--	V
Overvoltage hysteresis	$T_j = -40\dots+150^\circ\text{C}$ : $\Delta V_{bb(\text{over})}$	--	1	--	V
Overvoltage protection <sup>6)</sup> $I_{bb} = 40\text{ mA}$	$T_j = -40^\circ\text{C}$ : $V_{bb(\text{AZ})}$ $T_j = +25\dots+150^\circ\text{C}$	41 43	-- 47	-- 52	V
Standby current (pin 4) $V_{IN} = 0$	$T_j = -40\dots+25^\circ\text{C}$ : $I_{bb(\text{off})}$ $T_j = 150^\circ\text{C}$ :	--	4 12	15 25	$\mu\text{A}$
Off state output current (included in $I_{bb(\text{off})}$ ) $V_{IN} = 0$ ,	$T_j = -40\dots+150^\circ\text{C}$ : $I_{L(\text{off})}$	--	--	10	$\mu\text{A}$
Operating current (Pin 2) <sup>7)</sup> , $V_{IN} = 5\text{ V}$	$I_{GND}$	--	1.2	3	mA

<sup>5)</sup> At supply voltage increase up to  $V_{bb} = 4.7\text{ V}$  typ without charge pump,  $V_{OUT} \approx V_{bb} - 2\text{ V}$

<sup>6)</sup> Supply voltages higher than  $V_{bb(\text{AZ})}$  require an external current limit for the GND and status pins (a  $150\ \Omega$  resistor in the GND connection is recommended). See also  $V_{ON(\text{CL})}$  in table of protection functions and circuit diagram page 9.

<sup>7)</sup> Add  $I_{ST}$ , if  $I_{ST} > 0$ , add  $I_{IN}$ , if  $V_{IN} > 5.5\text{ V}$

Parameter and Conditions at $T_j = 25^\circ\text{C}$ , $V_{bb} = 12\text{ V}$ unless otherwise specified	Symbol	Values			Unit
		min	typ	max	
<b>Protection Functions<sup>8)</sup></b>					
Initial peak short circuit current limit (pin 4 to 6&7) $T_j = -40^\circ\text{C}$ : $T_j = 25^\circ\text{C}$ : $T_j = +150^\circ\text{C}$ :	$I_{L(SCp)}$	48 40 31	56 50 37	65 58 45	A
Repetitive short circuit shutdown current limit $T_j = T_{jt}$ (see timing diagrams, page 12)	$I_{L(SCr)}$	--	24	--	A
Output clamp (inductive load switch off) at $V_{OUT} = V_{bb} - V_{ON(CL)}$ ; $I_L = 40\text{ mA}$ , $T_j = -40^\circ\text{C}$ : $T_j = +25\dots+150^\circ\text{C}$ :	$V_{ON(CL)}$	41 43	-- 47	-- 52	V
Thermal overload trip temperature	$T_{jt}$	150	--	--	$^\circ\text{C}$
Thermal hysteresis	$\Delta T_{jt}$	--	10	--	K
Reverse battery (pin 4 to 2) <sup>9)</sup>	$-V_{bb}$	--	--	32	V
Reverse battery voltage drop ( $V_{out} > V_{bb}$ ) $I_L = -5\text{ A}$ $T_j = 150^\circ\text{C}$ :	$-V_{ON(rev)}$	--	600	--	mV

### Diagnostic Characteristics

Current sense ratio <sup>10)</sup> , static on-condition, $V_{IS} = 0\dots5\text{ V}$ , $V_{bb(on)} = 6.5^{11})\dots27\text{V}$ , $k_{ILIS} = I_L / I_{IS}$ $T_j = -40^\circ\text{C}$ , $I_L = 5\text{ A}$ : $T_j = -40^\circ\text{C}$ , $I_L = 0.5\text{ A}$ : $T_j = 25\dots+150^\circ\text{C}$ , $I_L = 5\text{ A}$ : $T_j = 25\dots+150^\circ\text{C}$ , $I_L = 0.5\text{ A}$ :	$k_{ILIS}$	4550 3300 4550 4000	5000 5000 5000 5000	6000 8000 5550 6500	
Current sense output voltage limitation $T_j = -40\dots+150^\circ\text{C}$ $I_{IS} = 0$ , $I_L = 5\text{ A}$ :	$V_{IS(lim)}$	5.4	6.1	6.9	V
Current sense leakage/offset current $T_j = -40\dots+150^\circ\text{C}$ $V_{IN} = 0$ , $V_{IS} = 0$ , $I_L = 0$ : $V_{IN} = 5\text{ V}$ , $V_{IS} = 0$ , $I_L = 0$ : $V_{IN} = 5\text{ V}$ , $V_{IS} = 0$ , $V_{OUT} = 0$ (short circuit):	$I_{IS(LL)}$ $I_{IS(LH)}$ $I_{IS(SH)}^{12)}$	0 0 0	-- -- --	1 15 10	$\mu\text{A}$

8) Integrated protection functions are designed to prevent IC destruction under fault conditions described in the data sheet. Fault conditions are considered as "outside" normal operating range. Protection functions are not designed for continuous repetitive operation.

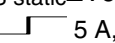
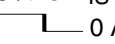
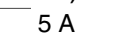
9) Requires 150  $\Omega$  resistor in GND connection. The reverse load current through the intrinsic drain-source diode has to be limited by the connected load. Note that the power dissipation is higher compared to normal operating conditions due to the voltage drop across the intrinsic drain-source diode. The temperature protection is not active during reverse current operation! Input and Status currents have to be limited (see max. ratings page 2 and circuit page 9).

10) This range for the current sense ratio refers to all devices. The accuracy of the  $k_{ILIS}$  can be raised at least by a factor of two by matching the value of  $k_{ILIS}$  for every single device.



In the case of current limitation the sense current  $I_{IS}$  is zero and the diagnostic feedback potential  $V_{ST}$  is High. See figure 2b, page 11.

11) Valid if  $V_{bb(u_{rst})}$  was exceeded before.

12) not subject to production test, specified by design

Parameter and Conditions at $T_j = 25^\circ\text{C}$ , $V_{bb} = 12\text{ V}$ unless otherwise specified	Symbol	Values			Unit
		min	typ	max	
Current sense settling time to $I_{IS\text{ static}} \pm 10\%$ after positive input slope <sup>13)</sup> , $I_L = 0$  5 A, $T_j = -40\dots+150^\circ\text{C}$	$t_{\text{son(IS)}}$	--	--	300	$\mu\text{s}$
Current sense settling time to 10% of $I_{IS\text{ static}}$ after negative input slope <sup>13)</sup> , $I_L = 5$  0 A, $T_j = -40\dots+150^\circ\text{C}$	$t_{\text{soff(IS)}}$	--	30	100	$\mu\text{s}$
Current sense rise time (60% to 90%) after change of load current <sup>13)</sup> , $I_L = 2.5$  5 A	$t_{\text{slc(IS)}}$	--	10	--	$\mu\text{s}$
Open load detection voltage <sup>14)</sup> (off-condition) $T_j = -40\dots+150^\circ\text{C}$ :	$V_{\text{OUT(OL)}}$	2	3	4	V
Internal output pull down (pin 6 to 2), $V_{\text{OUT}} = 5\text{ V}$ , $T_j = -40\dots+150^\circ\text{C}$	$R_O$	5	15	40	$\text{k}\Omega$

**Input and Status Feedback<sup>15)</sup>**

Input resistance see circuit page 8	$R_i$	3,0	4,5	7,0	$\text{k}\Omega$
Input turn-on threshold voltage  $T_j = -40\dots+150^\circ\text{C}$ :	$V_{\text{IN(T+)}}$	--	--	3.5	V
Input turn-off threshold voltage  $T_j = -40\dots+150^\circ\text{C}$ :	$V_{\text{IN(T-)}}$	1.5	--	--	V
Input threshold hysteresis	$\Delta V_{\text{IN(T)}}$	--	0.5	--	V
Off state input current (pin 3), $V_{\text{IN}} = 0.4\text{ V}$ $T_j = -40\dots+150^\circ\text{C}$	$I_{\text{IN(off)}}$	1	--	50	$\mu\text{A}$
On state input current (pin 3), $V_{\text{IN}} = 5\text{ V}$ $T_j = -40\dots+150^\circ\text{C}$	$I_{\text{IN(on)}}$	20	50	90	$\mu\text{A}$
Delay time for status with open load after Input neg. slope (see diagram page 13)	$t_{\text{d(ST OL3)}}$	--	400	--	$\mu\text{s}$
Status delay after positive input slope <sup>13)</sup> $T_j = -40\dots+150^\circ\text{C}$ :	$t_{\text{don(ST)}}$	--	13	--	$\mu\text{s}$
Status delay after negative input slope <sup>13)</sup> $T_j = -40\dots+150^\circ\text{C}$ :	$t_{\text{doff(ST)}}$	--	1	--	$\mu\text{s}$
Status output (open drain) Zener limit voltage $T_j = -40\dots+150^\circ\text{C}$ , $I_{\text{ST}} = +1.6\text{ mA}$ : ST low voltage $T_j = -40\dots+25^\circ\text{C}$ , $I_{\text{ST}} = +1.6\text{ mA}$ : $T_j = +150^\circ\text{C}$ , $I_{\text{ST}} = +1.6\text{ mA}$ :	$V_{\text{ST(high)}}$ $V_{\text{ST(low)}}$	5.4 -- --	6.1 -- --	6.9 0.4 0.7	V
Status leakage current, $V_{\text{ST}} = 5\text{ V}$ , $T_j = 25\dots+150^\circ\text{C}$ :	$I_{\text{ST(high)}}$	--	--	2	$\mu\text{A}$

<sup>13)</sup> not subject to production test, specified by design

<sup>14)</sup> External pull up resistor required for open load detection in off state.

<sup>15)</sup> If a ground resistor  $R_{\text{GND}}$  is used, add the voltage drop across this resistor.

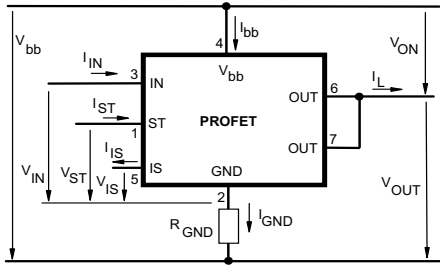
### Truth Table

	Input level	Output level	Status level	Current Sense $I_{IS}$
Normal operation	L	L	H	0
	H	H	L	nominal
Current-limitation	L	L	H	0
	H	H	H	0
Short circuit to GND	L	L	H	0
	H	L <sup>16)</sup>	H	0
Over-temperature	L	L	H	0
	H	L	H	0
Short circuit to $V_{bb}$	L	H	L <sup>17)</sup>	0
	H	H	L	<nominal <sup>18)</sup>
Open load	L	L <sup>19)</sup>	H (L <sup>20)</sup>	0
	H	H	L	0
Undervoltage	L	L	H	0
	H	L	L	0
Overvoltage	L	L	H	0
	H	L	L	0
Negative output voltage clamp	L	L	H	0

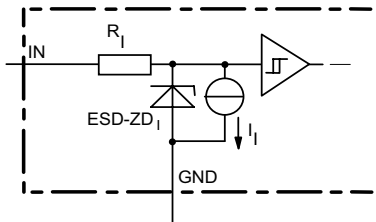
L = "Low" Level      X = don't care      Z = high impedance, potential depends on external circuit  
H = "High" Level      Status signal after the time delay shown in the diagrams (see fig 5. page 12...13)

- 16) The voltage drop over the power transistor is  $V_{bb} - V_{OUT} > \text{typ.} 3V$ . Under this condition the sense current  $I_{IS}$  is zero
- 17) An external short of output to  $V_{bb}$ , in the off state, causes an internal current from output to ground. If  $R_{GND}$  is used, an offset voltage at the GND and ST pins will occur and the  $V_{ST \text{ low}}$  signal may be errorious.
- 18) Low ohmic short to  $V_{bb}$  may reduce the output current  $I_L$  and therefore also the sense current  $I_{IS}$ .
- 19) Power Transistor off, high impedance
- 20) with external resistor between pin 4 and pin 6&7

## Terms

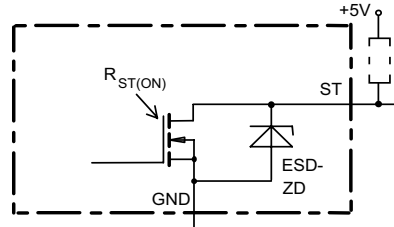


## Input circuit (ESD protection)



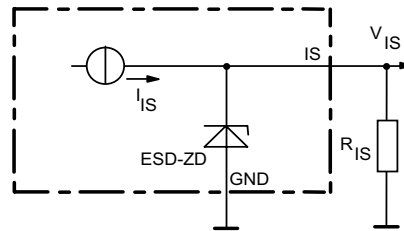
The use of ESD zener diodes as voltage clamp at DC conditions is not recommended.

## Status output



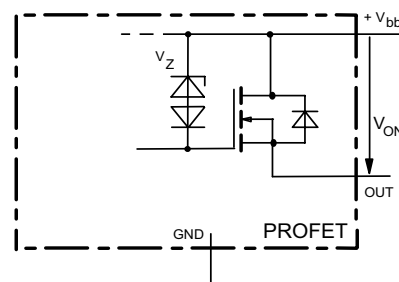
ESD-Zener diode: 6.1 V typ., max 5 mA;  
R<sub>ST(ON)</sub> < 440 Ω at 1.6 mA, The use of ESD zener diodes as voltage clamp at DC conditions is not recommended.

## Current sense output



ESD-Zener diode: 6.1 V typ., max 14 mA;  
R<sub>IS</sub> = 1 kΩ nominal

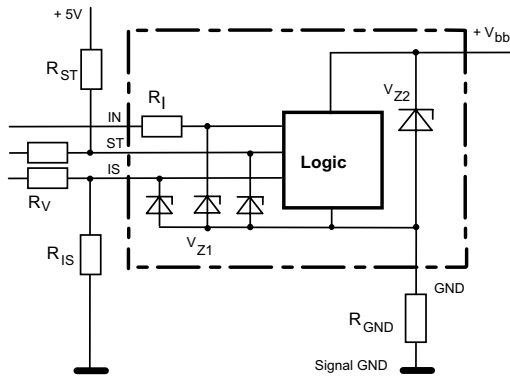
## Inductive and overvoltage output clamp



V<sub>ON</sub> clamped to 47 V typ.

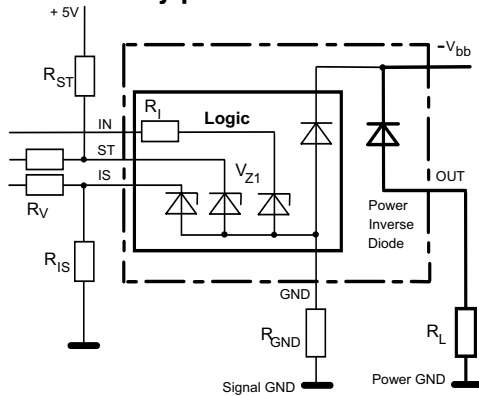


### Overtoltage protection of logic part



$V_{Z1} = 6.1 \text{ V typ.}$ ,  $V_{Z2} = 47 \text{ V typ.}$ ,  $R_I = 4 \text{ k}\Omega \text{ typ.}$ ,  
 $R_{GND} = 150 \Omega$ ,  $R_{ST} = 15 \text{ k}\Omega$ ,  $R_{IS} = 1 \text{ k}\Omega$ ,  $R_V = 15 \text{ k}\Omega$ ,

### Reverse battery protection

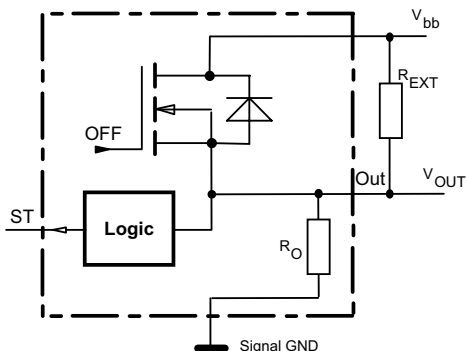


The load  $R_L$  is inverse on, temperature protection is not active

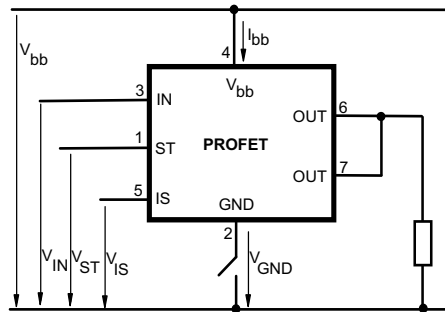
$R_{GND} = 150 \Omega$ ,  $R_I = 4 \text{ k}\Omega \text{ typ.}$ ,  $R_{ST} \geq 500 \Omega$ ,  $R_{IS} \geq 200 \Omega$ ,  
 $R_V \geq 500 \Omega$ ,

### Open-load detection

OFF-state diagnostic condition:  $V_{OUT} > 3 \text{ V typ.}$ ; IN low

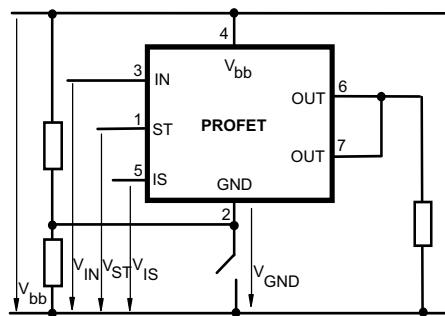


### GND disconnect



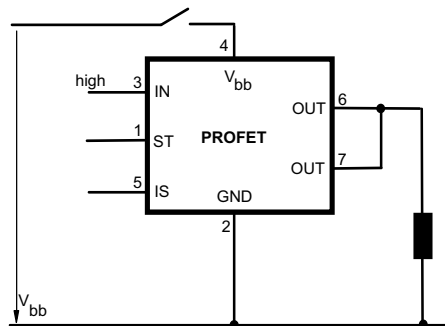
Any kind of load. In case of Input=high is  $V_{OUT} \approx V_{IN} - V_{IN(T+)}$ .  
Due to  $V_{GND} > 0$ , no  $V_{ST} = \text{low signal}$  available.

### GND disconnect with GND pull up



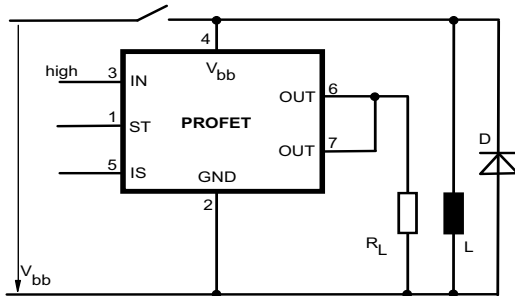
Any kind of load. If  $V_{GND} > V_{IN} - V_{IN(T+)}$  device stays off  
Due to  $V_{GND} > 0$ , no  $V_{ST} = \text{low signal}$  available.

### V<sub>bb</sub> disconnect with energized inductive load



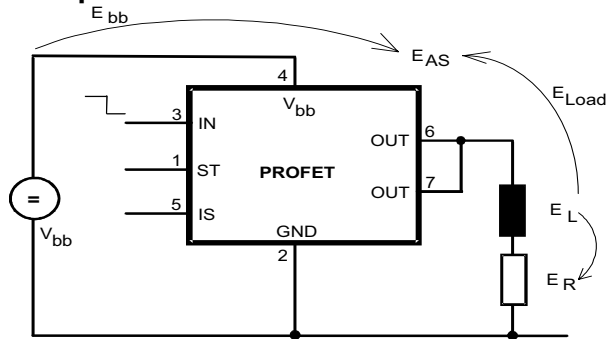
Normal load current can be handled by the PROFET itself.

## V<sub>bb</sub> disconnect with charged external inductive load



If other external inductive loads L are connected to the PROFET, additional elements like D are necessary.

## Inductive Load switch-off energy dissipation



Energy stored in load inductance:

$$E_L = \frac{1}{2} \cdot L \cdot I_L^2$$

While demagnetizing load inductance, the energy dissipated in PROFET is

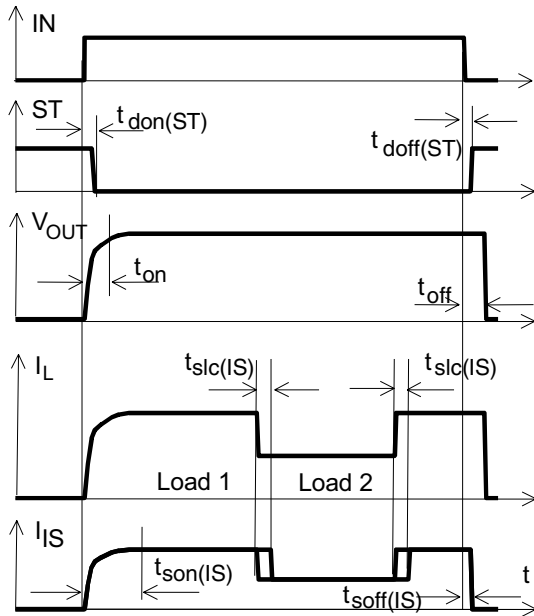
$$E_{AS} = E_{bb} + E_L - E_R = V_{ON(CL)} \cdot i_L(t) \, dt,$$

with an approximate solution for  $R_L > 0 \, \Omega$ :

$$E_{AS} = \frac{I_L \cdot L}{2 \cdot R_L} \cdot (V_{bb} + |V_{OUT(CL)}|) \cdot \ln \left( 1 + \frac{I_L \cdot R_L}{|V_{OUT(CL)}|} \right)$$

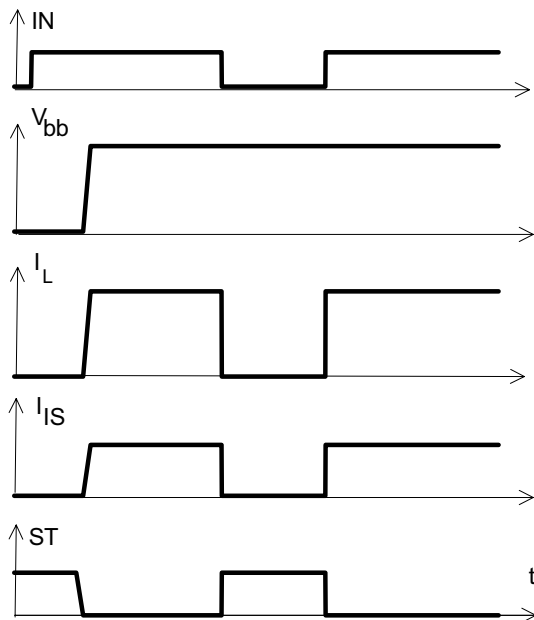
## Timing diagrams

**Figure 1a:** Switching a resistive load, change of load current in on-condition:

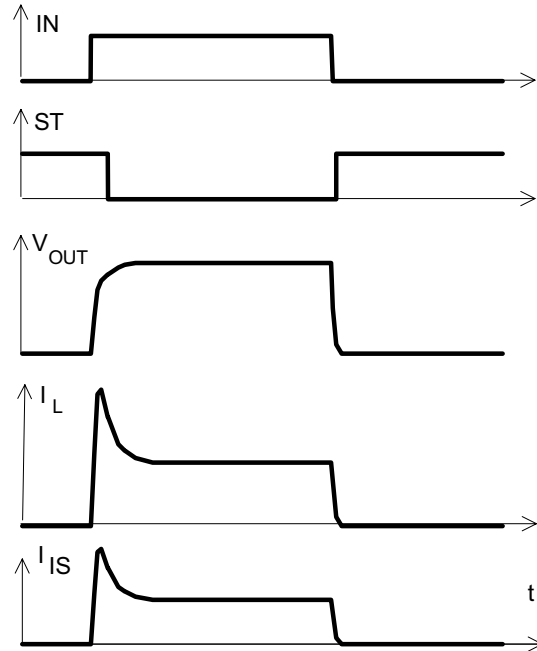


The sense signal is not valid during settling time after turn on or change of load current.

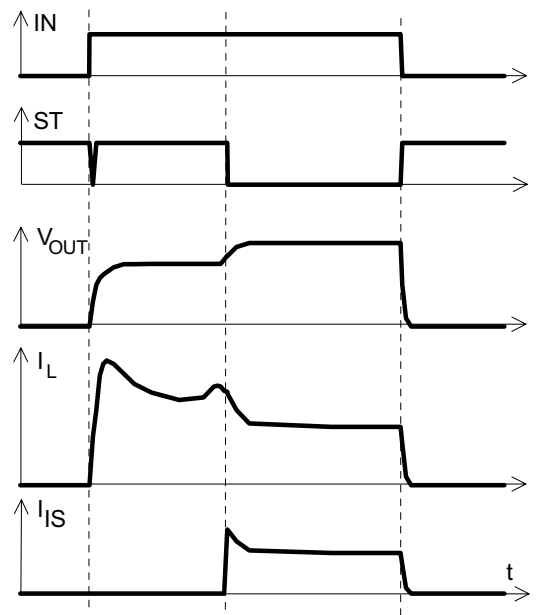
**Figure 1b:**  $V_{bb}$  turn on:



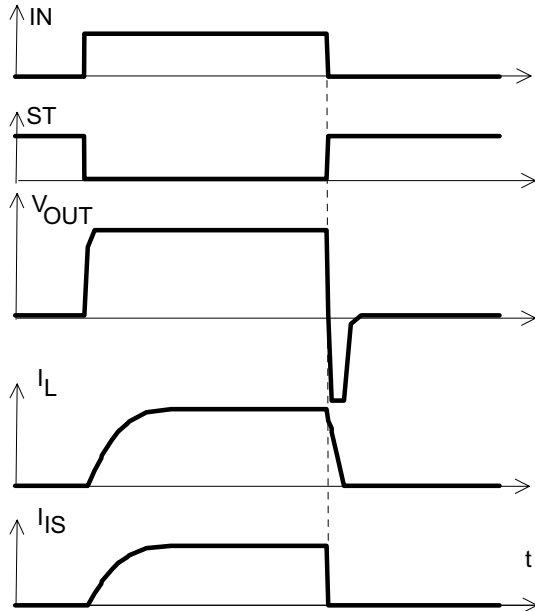
**Figure 2a:** Switching a lamp



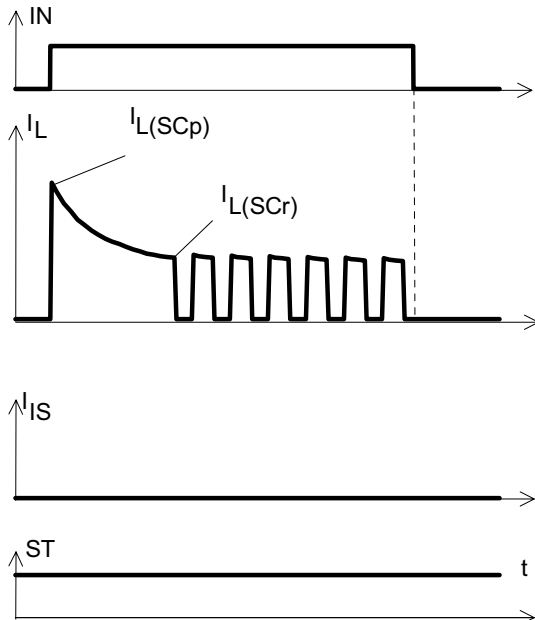
**Figure 2b:** Switching a lamp with current limit:



**Figure 2c:** Switching an inductive load:

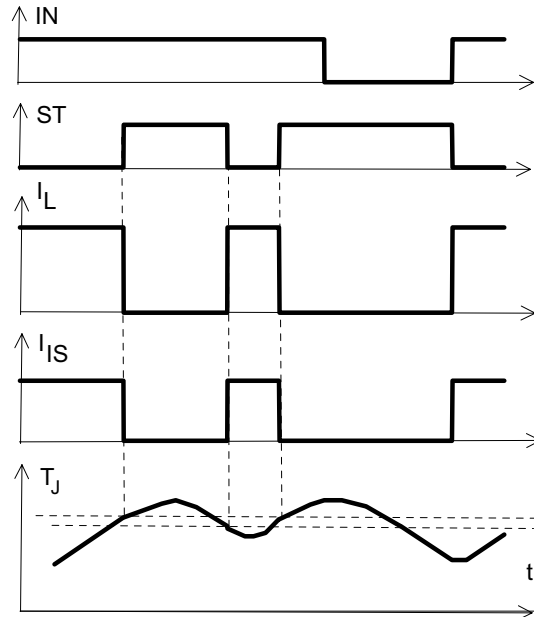


**Figure 3a:** Short circuit: shut down by overtemperature, reset by cooling

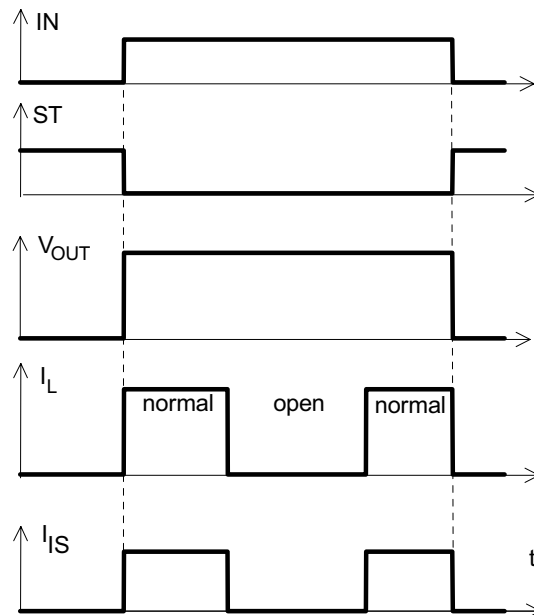


Heating up may require several milliseconds, depending on external conditions  
 $I_{L(SCp)} = 50 \text{ A}$  typ. increases with decreasing temperature.

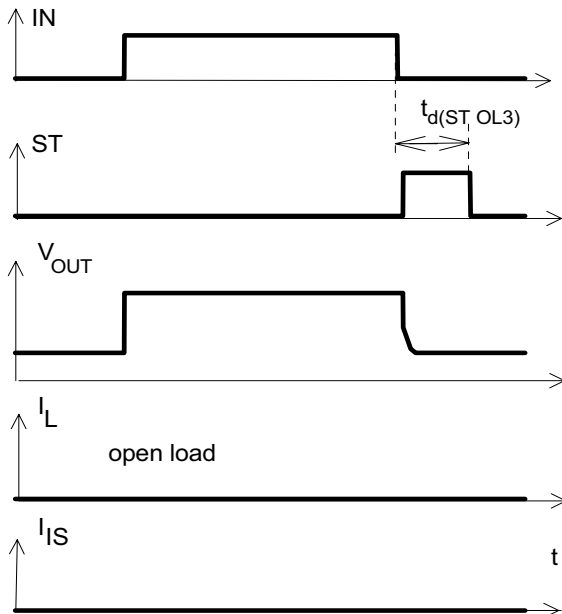
**Figure 4a:** Overtemperature: Reset if  $T_j < T_{jt}$



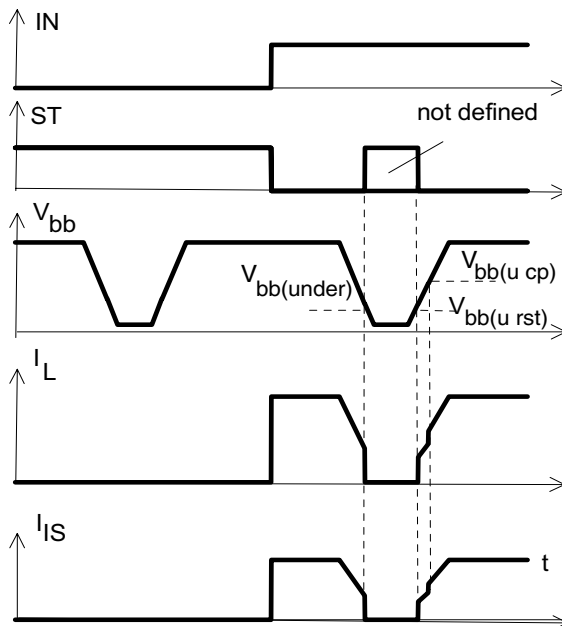
**Figure 5a:** Open load: detection in ON-state, open load occurs in on-state



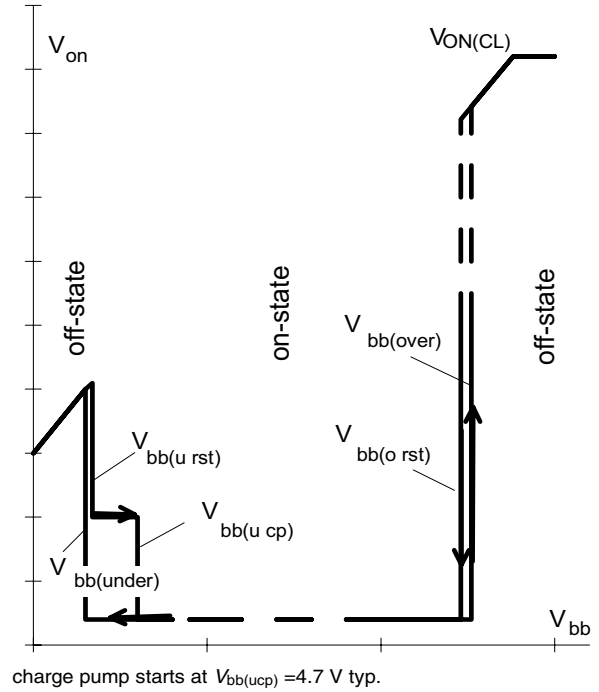
**Figure 5b:** Open load: detection in ON- and OFF-state (with  $R_{EXT}$ ), turn on/off to open load



**Figure 6a:** Undervoltage:



**Figure 6b:** Undervoltage restart of charge pump



**Figure 7a:** Overvoltage:

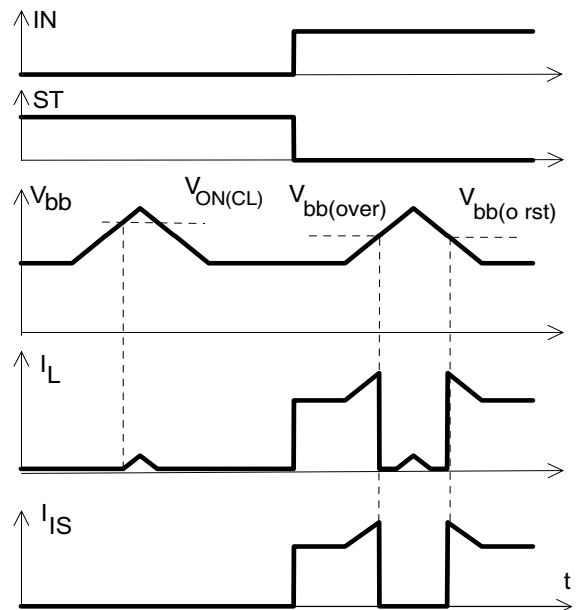


Figure 8a: Current sense versus load current:

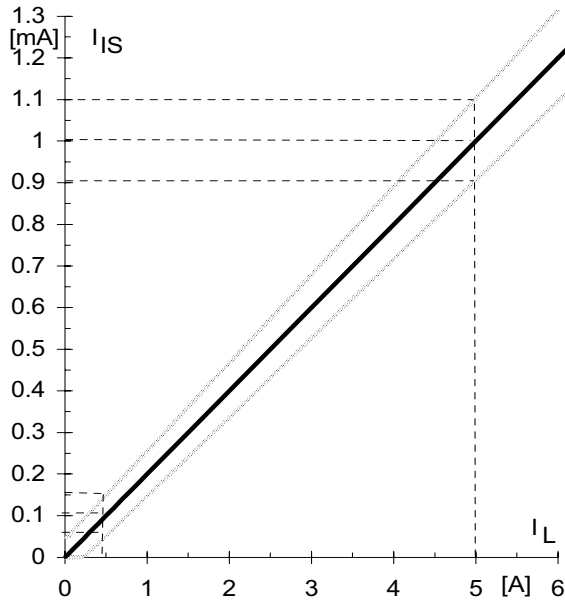


Figure 8b: Current sense ratio<sup>21</sup>:

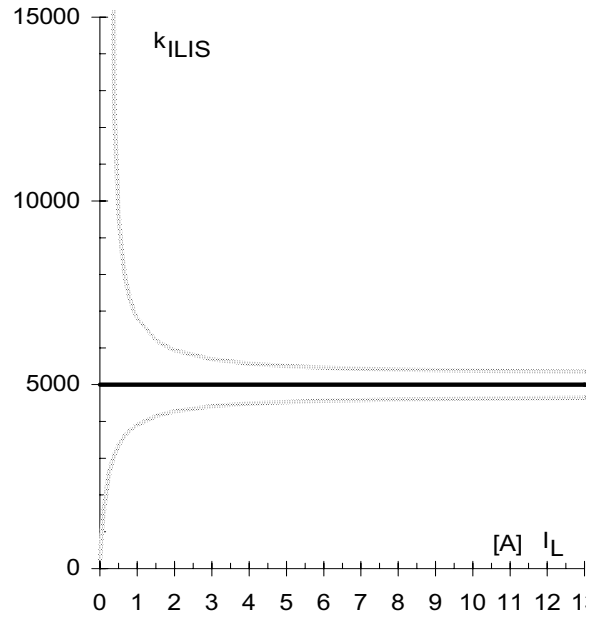
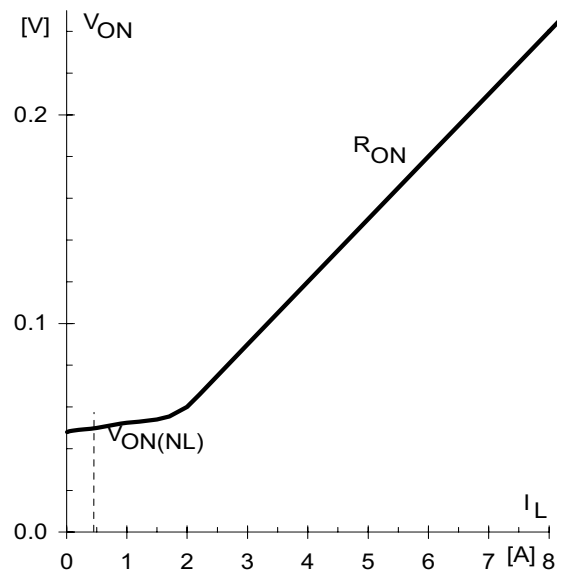
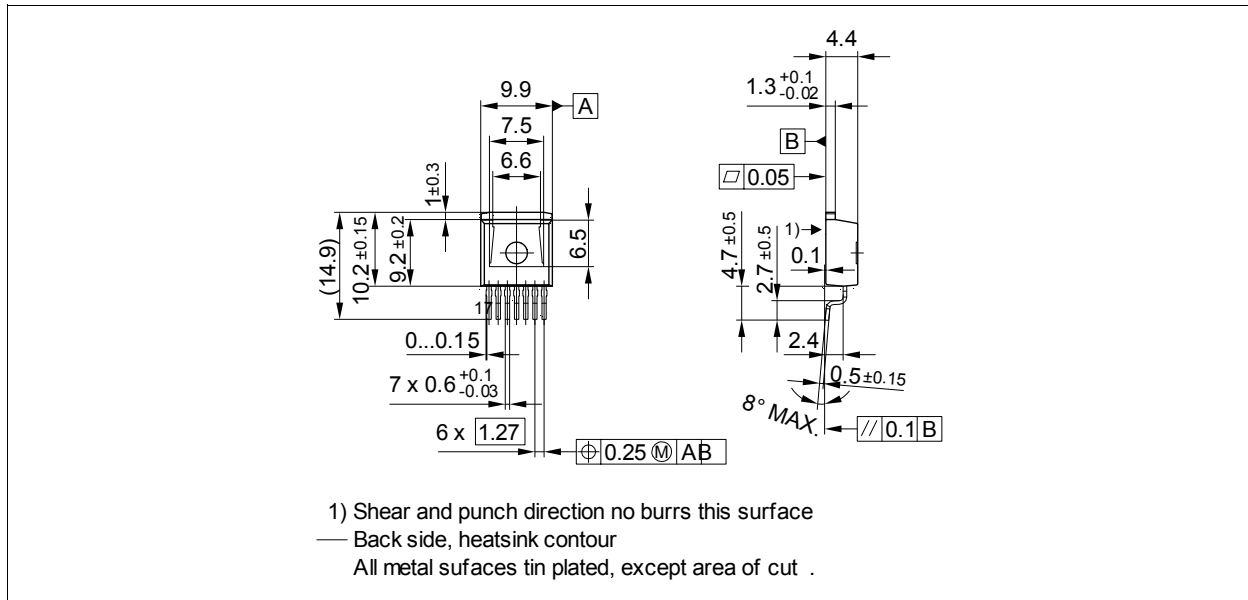


Figure 9a: Output voltage drop versus load current:



<sup>21</sup> This range for the current sense ratio refers to all devices. The accuracy of the  $k_{ILIS}$  can be raised at least by a factor of two by matching the value of  $k_{ILIS}$  for every single device.

## Package Outlines



**Figure 1** PG-TO-263-7-2 (Plastic Dual Small Outline Package) (RoHS-compliant)

To meet the world-wide customer requirements for environmentally friendly products and to be compliant with government regulations the device is available as a green product. Green products are RoHS-Compliant (i.e Pb-free finish on leads and suitable for Pb-free soldering according to IPC/JEDEC J-STD-020).

Please specify the package needed (e.g. green package) when placing an order

## Revision History

Version	Date	Changes
V1.1	2008-19-08	Creation of the green datasheet. First page : Adding the green logo and the AEC qualified Adding the bullet AEC qualified and the RoHS compliant features Package page Modification of the package to be green.



**Edition 2008-19-08**

**Published by  
Infineon Technologies AG  
81726 Munich, Germany**

**© Infineon Technologies AG 8/19/08.  
All Rights Reserved.**

### **Legal Disclaimer**

The information given in this document shall in no event be regarded as a guarantee of conditions or characteristics ("Beschaffenhheitsgarantie"). With respect to any examples or hints given herein, any typical values stated herein and/or any information regarding the application of the device, Infineon Technologies hereby disclaims any and all warranties and liabilities of any kind, including without limitation warranties of non-infringement of intellectual property rights of any third party.

### **Information**

For further information on technology, delivery terms and conditions and prices please contact your nearest Infineon Technologies Office ([www.infineon.com](http://www.infineon.com)).

### **Warnings**

Due to technical requirements components may contain dangerous substances. For information on the types in question please contact your nearest Infineon Technologies Office.

Infineon Technologies Components may only be used in life-support devices or systems with the express written approval of Infineon Technologies, if a failure of such components can reasonably be expected to cause the failure of that life-support device or system, or to affect the safety or effectiveness of that device or system. Life support devices or systems are intended to be implanted in the human body, or to support and/or maintain and sustain and/or protect human life. If they fail, it is reasonable to assume that the health of the user or other persons may be endangered.