

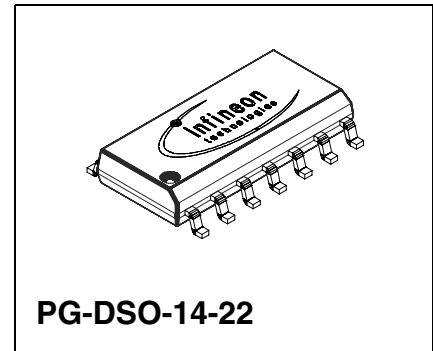

Overview

Features

- Optimized for headlight beam control applications
- Current-peak-blanking (no electrolytic capacitor at V_S)
- Delivers up to 0.8 A continuous
- Low saturation voltage; typ.1.2 V total @ 25 °C; 0.4 A
- Output protected against short circuit
- Overtemperature protection with hysteresis
- Over- and undervoltage lockout
- No crossover current
- Internal clamp diodes
- Enhanced power packages
- Green Product (RoHS compliant)
- AEC Qualified



Type	Ordering Code	Package
TLE 4206G	on request	PG-DSO-14-22

Description

The TLE 4206G is a fully protected H-Bridge Driver designed specifically for automotive headlight beam control and industrial servo control applications. The part is built using the Siemens bipolar high voltage power technology DOPL.

The standard enhanced power PG-DSO-14-22 package meets the application requirements and saves PCB-board space and costs. Moreover the package is RoHS compliant.

The servo-loop-parameter pos.- and neg. Hysteresis, pos.- and neg. deadband and angle-amplification are programmable with external resistors.

An internal window-comparator controls the input line. In the case of a fault condition, like short circuit to GND, short circuit to supply-voltage, and broken wire, the TLE 4206 stops the motor immediately (brake condition).

The “programmable current-peak-blanking” disables the servo-loop during the V_S voltage drop caused by the stall current spike. So there is no need of an electrolytic blocking capacitor at the V_S -terminal.

Furthermore the built in features like over- and undervoltage-lockout, short-circuit-protection and over-temperature-protection will open a wide range of automotive- and industrial applications.

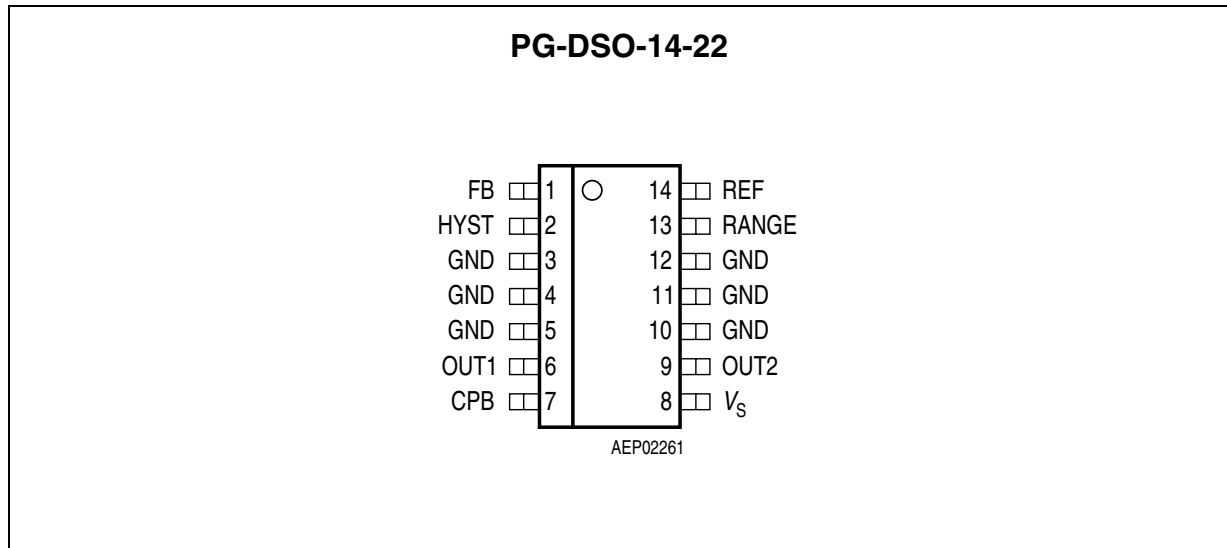

Figure 1 Pin Configuration (top view)

Pin Definitions and Functions

Pin No. P-DSO-14-8	Symbol	Function
1	FB	Feedback Input
2	HYST	Hysteresis I/O
3, 4, 5, 10, 11, 12	GND	Ground
6	OUT1	Power Output 1
7	CPB	Current Peak Blanking Input
8	V_S	Power Supply Voltage
9	OUT2	Power Output 2
13	RANGE	Range Input
14	REF	Reference Input

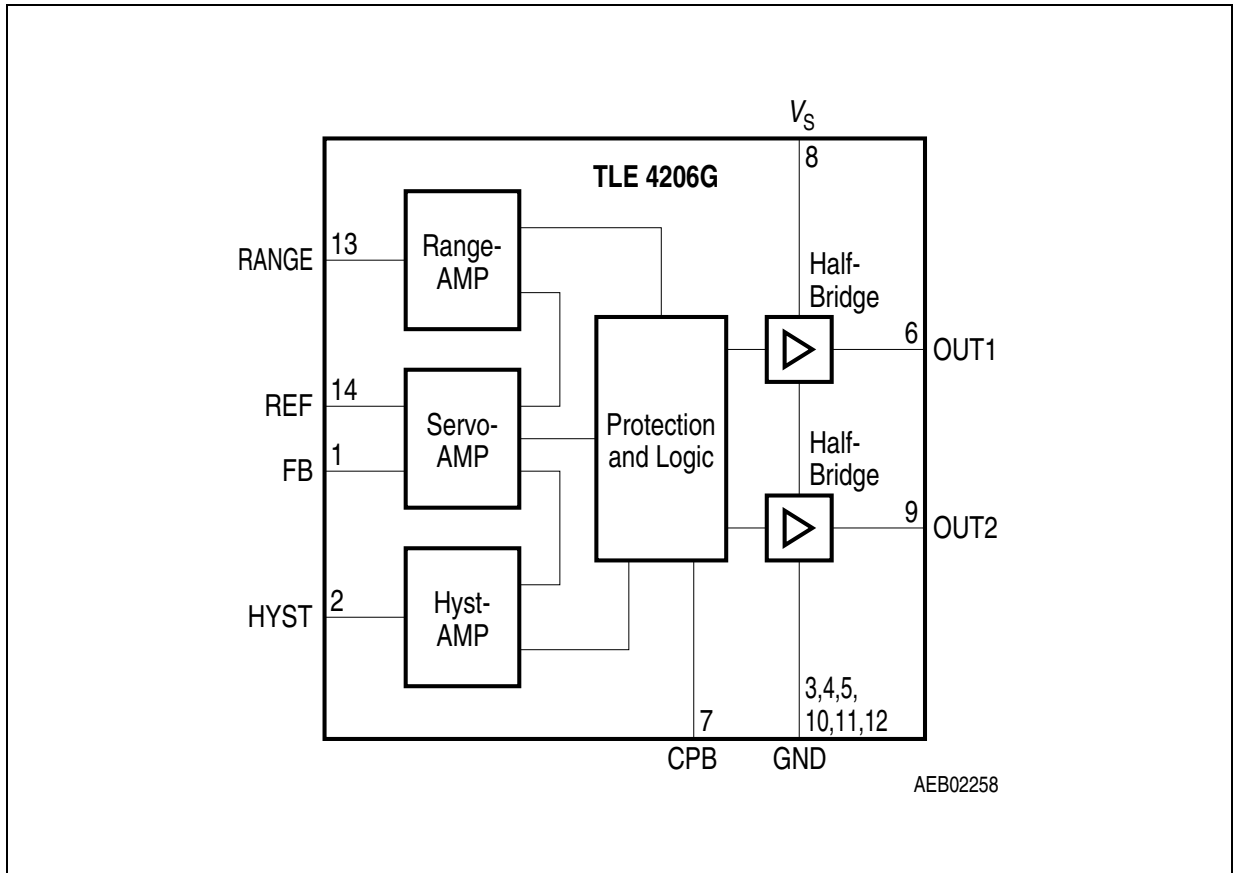

Figure 2 Block Diagram

Absolute Maximum Ratings

Parameter	Symbol	Limit Values		Unit	Remarks
		min.	max.		

Voltages

Supply voltage	V_S	- 0.3	45	V	-
Supply voltage	V_S	- 1	-	V	$t < 0.5 \text{ s}; I_S > - 2 \text{ A}$
Logic input voltages (FB, REF, RANGE, HYST, CPB)	V_I	- 0.3	20	V	-

Currents

Output current (OUT1, OUT2)	I_{OUT}	-	-	A	internally limited
Output current (Diode)	I_{OUT}	- 1	1	A	-
Input current (FB, REF, RANGE, HYST)	I_{IN}	- 2 - 6	2 6	mA mA	$t < 2 \text{ ms}; t/T < 0.1$

Temperatures

Junction temperature	T_j	- 40	150	°C	-
Storage temperature	T_{stg}	- 50	150	°C	-

Thermal Resistances

Junction pin (PG-DSO-14-22)	$R_{thj-pin}$	-	25	K/W	measured to pin 5
Junction ambient (PG-DSO-14-22)	R_{thjA}	-	65	K/W	-

Note: Maximum ratings are absolute ratings; exceeding any one of these values may cause irreversible damage to the integrated circuit.

Operating Range

Parameter	Symbol	Limit Values		Unit	Remarks
		min.	max.		
Supply voltage	V_S	8	18	V	After V_S rising above $V_{UV\ ON}$
Supply voltage increasing	V_S	- 0.3	$V_{UV\ ON}$	V	Outputs in tristate
Supply voltage decreasing	V_S	- 0.3	$V_{UV\ OFF}$	V	Outputs in tristate
Output current	I_{OUT1-2}	- 0.8	0.8	A	-
Input current (FB, REF)	I_{IN}	- 50	500	μA	-
Junction temperature	T_j	- 40	150	$^{\circ}C$	-

Electrical Characteristics
 $8\text{ V} < V_S < 18\text{ V}; I_{\text{OUT}1-2} = 0\text{ A}; -40\text{ }^\circ\text{C} < T_j < 150\text{ }^\circ\text{C}$
 (unless otherwise specified)

Parameter	Symbol	Limit Values			Unit	Test Condition
		min.	typ.	max.		

Current Consumption

Supply current	I_S	–	12	20	mA	–
Supply current	I_S	–	20	30	mA	$I_{\text{OUT}1} = 0.4\text{ A}$ $I_{\text{OUT}2} = -0.4\text{ A}$
Supply current	I_S	–	30	50	mA	$I_{\text{OUT}1} = 0.8\text{ A}$ $I_{\text{OUT}2} = -0.8\text{ A}$

Over- and Under Voltage Lockout

UV Switch ON voltage	$V_{\text{UV ON}}$	–	7.4	8	V	V_S increasing
UV Switch OFF voltage	$V_{\text{UV OFF}}$	6.3	6.9	–	V	V_S decreasing
UV ON/OFF Hysteresis	V_{UVHY}	–	0.5	–	V	$V_{\text{UV ON}} - V_{\text{UV OFF}}$
OV Switch OFF voltage	$V_{\text{OV OFF}}$	–	20.5	23	V	V_S increasing
OV Switch ON voltage	$V_{\text{OV ON}}$	17.5	20	–	V	V_S decreasing
OV ON/OFF Hysteresis	V_{OVHY}	–	0.5	–	V	$V_{\text{OV OFF}} - V_{\text{OV ON}}$

Electrical Characteristics (cont'd)

8 V < V_S < 18 V; $I_{OUT1-2} = 0$ A; -40 °C < T_j < 150 °C
(unless otherwise specified)

Parameter	Symbol	Limit Values			Unit	Test Condition
		min.	typ.	max.		

Outputs OUT1-2
Saturation Voltages

Source (upper) $I_{OUT} = -0.2$ A	$V_{SAT U}$	–	0.85	1.15	V	$T_j = 25$ °C
Source (upper) $I_{OUT} = -0.4$ A	$V_{SAT U}$	–	0.90	1.20	V	$T_j = 25$ °C
Sink (upper) $I_{OUT} = -0.8$ A	$V_{SAT U}$	–	1.10	1.50	V	$T_j = 25$ °C
Sink (lower) $I_{OUT} = 0.2$ A	$V_{SAT L}$	–	0.15	0.23	V	$T_j = 25$ °C
Sink (lower) $I_{OUT} = 0.4$ A	$V_{SAT L}$	–	0.25	0.40	V	$T_j = 25$ °C
Sink (lower) $I_{OUT} = 0.8$ A	$V_{SAT L}$	–	0.45	0.75	V	$T_j = 25$ °C

Total drop	$I_{OUT} = 0.2$ A	V_{SAT}	–	1.0	1.4	V	$V_{SAT} = V_{SAT U} + V_{SAT L}$
Total drop	$I_{OUT} = 0.4$ A	V_{SAT}	–	1.2	1.7	V	$V_{SAT} = V_{SAT U} + V_{SAT L}$
Total drop	$I_{OUT} = 0.8$ A	V_{SAT}	–	1.6	2.5	V	$V_{SAT} = V_{SAT U} + V_{SAT L}$

Clamp Diodes

Forward voltage; upper	V_{FU}	–	1	1.5	V	$I_F = 0.4$ A
Upper leakage current	I_{LKU}	–	–	5	mA	$I_F = 0.4$ A
Forward voltage; lower	V_{FL}	–	0.9	1.4	V	$I_F = 0.4$ A

Electrical Characteristics (cont'd)

8 V < V_S < 18 V; $I_{OUT1-2} = 0$ A; -40 °C < T_j < 150 °C
(unless otherwise specified)

Parameter	Symbol	Limit Values			Unit	Test Condition
		min.	typ.	max.		

Input-Interface
Input REF

Quiescent voltage	V_{REFq}	–	200	–	mV	$I_{REF} = 0$ μ A
Input resistance	R_{REF}	–	6	–	k Ω	0 V < V_{REF} < 0.5 V

Input FB

Quiescent voltage	V_{FBq}	–	200	–	mV	$I_{FB} = 0$ μ A
Input resistance	R_{FB}	–	6	–	k Ω	0 V < V_{FB} < 0.5 V

Input/Output HYST

Current Amplification $A_{HYST} = I_{HYST} / (I_{REF} - I_{FB})$	A_{HYST}	0.8	0.95	1.1	–	-20 μ A < I_{HYST} < -10 μ A; 10 μ A < I_{HYST} < 20 μ A; $I_{REF} = 250$ μ A $V_{HYST} = V_S / 2$
Current Offset	I_{HYSTIO}	– 2	0.35	3	μ A	$I_{REF} = I_{FB} = 250$ μ A $V_{HYST} = V_S / 2$
Threshold voltage High	V_{HYH} / V_S	–	52	–	%	–
Deadband voltage High	V_{DBH} / V_S	–	50.4	–	%	–
Deadband voltage Low	V_{DBL} / V_S	–	49.6	–	%	–
Threshold voltage Low	V_{HYL} / V_S	–	48	–	%	–
Hysteresis Window	V_{HYW} / V_S	3	4	5	%	$(V_{HYH} - V_{HYL}) / V_S$
Deadband Window	V_{DBW} / V_S	0.4	0.8	1.2	%	$(V_{DBH} - V_{DBL}) / V_S$

Electrical Characteristics (cont'd)

8 V < V_S < 18 V; $I_{OUT1-2} = 0$ A; -40 °C < T_j < 150 °C
(unless otherwise specified)

Parameter	Symbol	Limit Values			Unit	Test Condition
		min.	typ.	max.		

Input RANGE

Input current	I_{RANGE}	- 1	-	1	μA	0 V < V_{RANGE} < V_S
Switch-OFF voltage High	V_{OFFH}	- 25	0	100	mV	refer to V_S
Switch-OFF voltage Low	V_{OFFL}	300	400	500	mV	refer to GND

Input CPB (Current Peak Blanking)

Charge current	I_{CPBCH}	-	6.5	-	μA	$V_{HYL} > V_{HYST}$; $V_{CPB} = 0$ V
Low voltage	V_{CPBL}	-	20	100	mV	$V_{HYL} < V_{HYST}$ < V_{HYH}
High voltage threshold	V_{CPBH}	5	5.7	6.5	V	$V_{HYL} > V_{HYST}$
Clamp voltage	V_{CPBC}	-	6.2	-	V	$V_{HYL} > V_{HYST}$
Blanking time	t_{CPB}	-	40	-	ms	$C_{CPB} = 47$ nF

Thermal Shutdown

Thermal shutdown junction temperature	T_{jSD}	150	175	200	°C	-
Thermal switch-on junction temperature	T_{jSO}	120	-	170	°C	-
Temperature hysteresis	ΔT	-	30	-	K	-

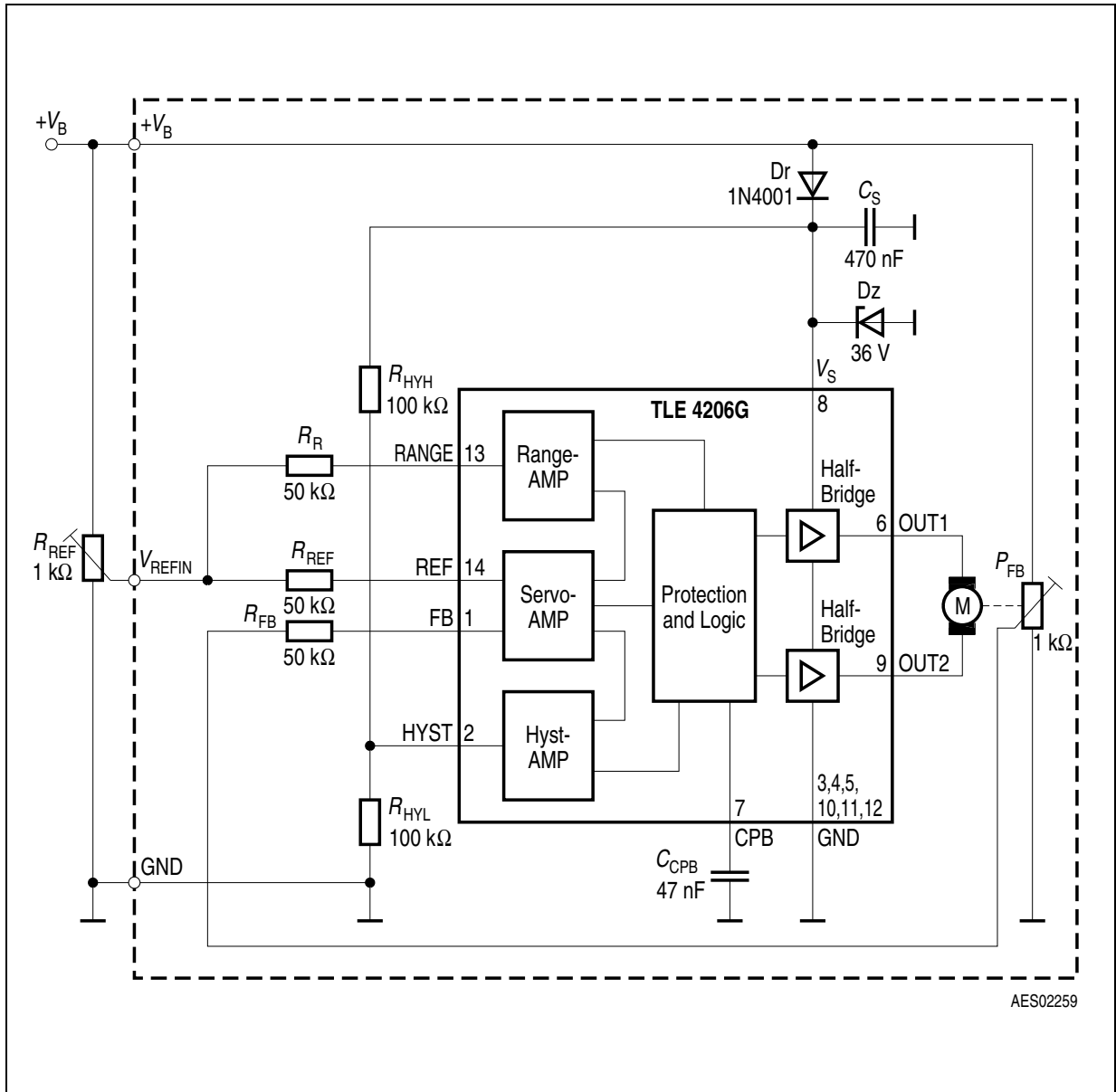

AES02259

Figure 3 Application Circuit

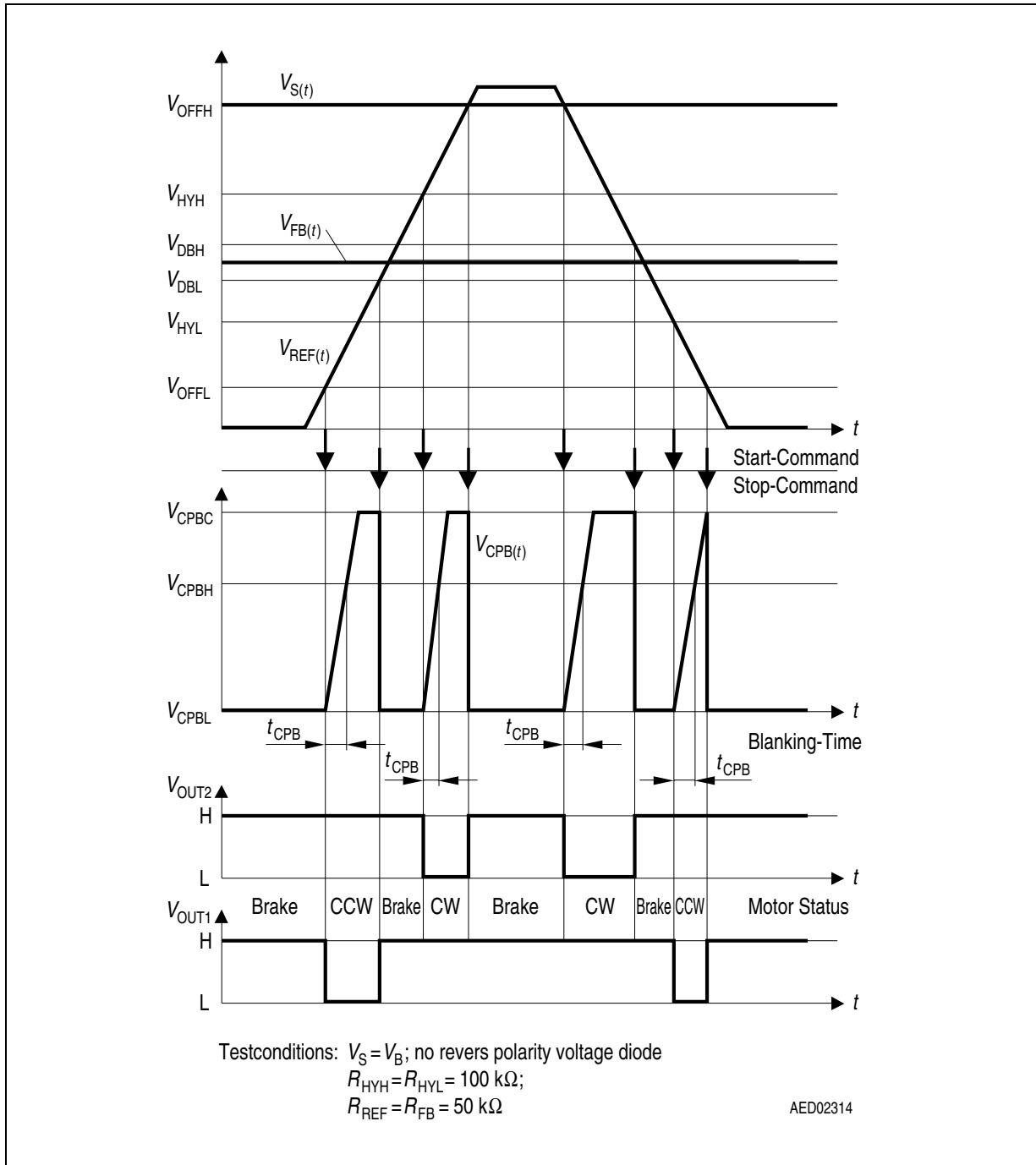
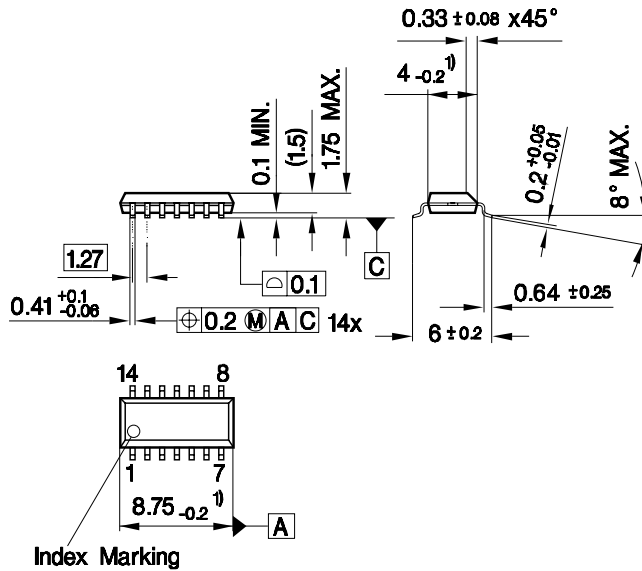

Figure 5 Timing and Phaselag

Package Outlines

PG-DSO-14-22

(Plastic Green - Dual Small Outline Package)



1) Does not include plastic or metal protrusion of 0.15 max. per side

Green Product (RoHS compliant)

To meet the world-wide customer requirements for environmentally friendly products and to be compliant with government regulations the device is available as a green product. Green products are RoHS-Compliant (i.e Pb-free finish on leads and suitable for Pb-free soldering according to IPC/JEDEC J-STD-020).

You can find all of our packages, sorts of packing and others in our Infineon Internet Page "Products": <http://www.infineon.com/products>.

SMD = Surface Mounted Device

Dimensions in mm

Revision History

Version	Date	Changes
Rev. 1.1	2007-08-10	<p>RoHS-compliant version of the TLE 4206</p> <ul style="list-style-type: none">• All pages: Infineon logo updated• Page 1: “AEC qualified” and “RoHS” logo added, “Green Product (RoHS compliant)” and “AEC qualified” statement added to feature list, package names changed to RoHS compliant versions, package pictures updated, ordering codes removed• Page 13: Package names changed to RoHS compliant versions, “Green Product” description added• Revision History added• Legal Disclaimer added

Edition 2007-08-10

**Published by
Infineon Technologies AG
81726 Munich, Germany**

**© 8/10/07 Infineon Technologies AG
All Rights Reserved.**

Legal Disclaimer

The information given in this document shall in no event be regarded as a guarantee of conditions or characteristics. With respect to any examples or hints given herein, any typical values stated herein and/or any information regarding the application of the device, Infineon Technologies hereby disclaims any and all warranties and liabilities of any kind, including without limitation, warranties of non-infringement of intellectual property rights of any third party.

Information

For further information on technology, delivery terms and conditions and prices, please contact the nearest Infineon Technologies Office (www.infineon.com).

Warnings

Due to technical requirements, components may contain dangerous substances. For information on the types in question, please contact the nearest Infineon Technologies Office.

Infineon Technologies components may be used in life-support devices or systems only with the express written approval of Infineon Technologies, if a failure of such components can reasonably be expected to cause the failure of that life-support device or system or to affect the safety or effectiveness of that device or system. Life support devices or systems are intended to be implanted in the human body or to support and/or maintain and sustain and/or protect human life. If they fail, it is reasonable to assume that the health of the user or other persons may be endangered.