

# Technical Information

ModSTACK™ 6MS2400R17KE3-3WAH-I6C20VIN



**Vorläufige Daten**  
preliminary data

## Key data

3x 750A RMS at 700V RMS, water cooled

## General information

Stacks for various inverter application. Semiconductors, heat sinks, capacitors, drivers and sensors included. These are only technical data!

Please read carefully the complete documentation and maintain the proper design environment! Especially note the EMC environment and the controller's functionality.

Topology		DC Link + B6I
Application / Modulation		Inverter / Sine
Load type		resistive, inductive
Cooling		water cooled
Implemented sensors		current, voltage, temperature
Semicond. (Unit 1)		none
DC Link		18.87mF
Semicond. (Unit 2)	IGBT	6x FF1200R17KE3
Driver signals IGBT		electrical CMOS 0 .. 15V
Standards		EN50178
Sales - name		6MS24017E33W33847
Internal ID		33847
Mechanical drawing number		33847_MB
Electrical drawing number		2PS-C2-V
Dimensions (width x depth x height)		1090 mm x 596 mm x 272 mm
Weight		90 kg

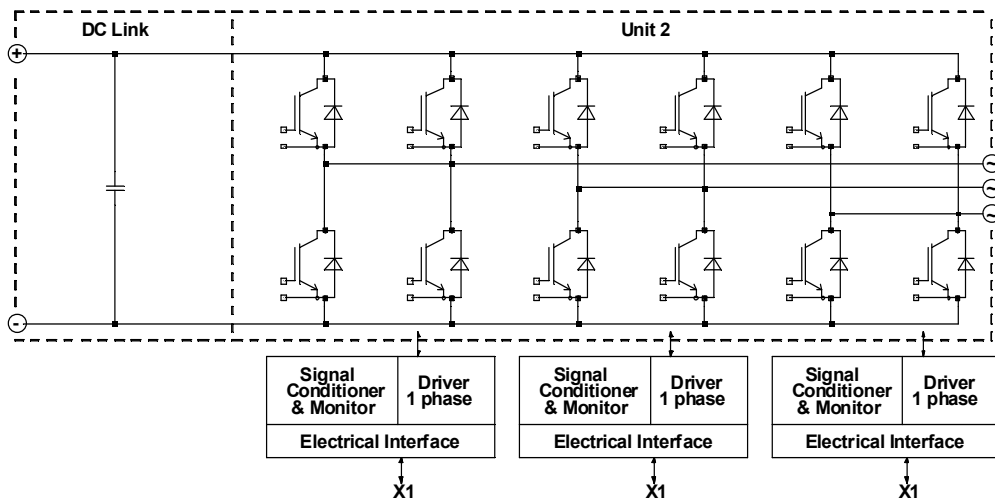
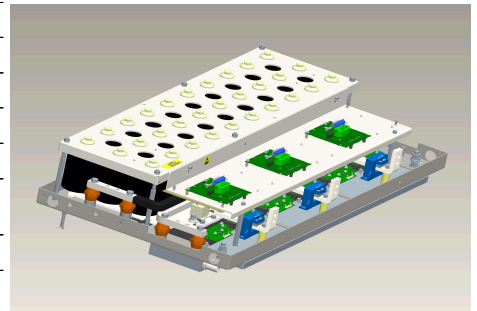

prepared by: Hoelbe Oliver	date of publication: 2010-03-25
approved by: Marco Bohländer	revision: 2.0

# Technical Information

ModSTACK™ 6MS2400R17KE3-3WAH-I6C20VIN



## Vorläufige Daten preliminary data

### Note

Heat sink with aluminum cooling channel.  
Composites of fluid: Water and 52 vol. % Antifrogen N.

### Electrical data

DC Link		min	typ	max	units
Voltage		$V_{DC}$	1150	1250	V
Overvoltage shutdown	within 5000 $\mu$ s		1250		V

Unit 2 AC		min	typ	max	units
Voltage	depending on controller	$V_{Unit2}$	700		$V_{RMS}$
Continuous current	$V_{Unit2} = 700V_{RMS}$ , $V_{DC} = 1200V$ , $T_{inlet} = 50^{\circ}C$ , $T_J \leq 125^{\circ}C$ , $f_{Unit2} = 50Hz$ , $f_{sw2} = 2500Hz$ , $\cos(\phi) = 0,95$	$I_{Unit2}$		750	$A_{RMS}$
Continuous current overload cap.	$T_{inlet} = 50^{\circ}C$ , for overload capability 150% for 60s		613		$A_{RMS}$
Short time current	$T_{inlet} = 50^{\circ}C$ , 10s, every 180s, initial load = 736 $A_{RMS}$	$I_{Unit2}$		920	$A_{RMS}$
DC current	no rotating field, $T_{inlet} = 50^{\circ}C$	$I_{Unit2 DC}$		300,0	$A_{av}$
Overcurrent shutdown	within 15 $\mu$ s		1300		$A_{peak}$
Switching frequency		$f_{sw2}$		3000	Hz
Power losses	$V_{Unit2} = 700V$ , $V_{DC} = 1200V$ , $T_{inlet} = 50^{\circ}C$ , $T_J \leq 125^{\circ}C$ , $f_{Unit2} = 50Hz$ , $f_{sw2} = 2500Hz$ , $\cos(\phi) = 0,95$ , $I_{Unit2} = 750A_{RMS}$	$P_{loss2}$	11150		W
Power factor		$\cos(\phi)_{Unit2}$	-1,00	1,00	

General data		min	typ	max	units
Power losses (PCB and capacitor)		$P_{loss aux}$		400	W
EMC test	according to IEC61800-3 at named interfaces	power	$V_{Burst}$	2	kV
		control	$V_{Burst}$	1	kV
		aux (24V)	$V_{Surge}$	1	kV
Insulation management is designed for		$V_{Line}$	690		$V_{RMS}$
Insulation test voltage	according to EN50178, $f = 50Hz$ , $t = 60s$	$V_{isol}$	2,5		kV $_{RMS}$

Important component data		min	typ	max	units
DC Link capacitor		$C_{DC}$	18,87		mF
		type	Electrolytic Capacitor		
wiring system	series, parallel		3s, 10p		
Balance or discharge resistors	per DC Link unit	$R_b$	6,0		k $\Omega$

prepared by: Hoelbe Oliver	date of publication: 2010-03-25
approved by: Marco Bohlländer	revision: 2.0

# Technical Information

ModSTACK™ 6MS2400R17KE3-3WAH-I6C20VIN



## Vorläufige Daten preliminary data

### Controller interface data

			min	typ	max	units
Auxiliary voltage		$V_{aux}$	18	24	30	$V_{av}$
Auxiliary power requirement	$V_{aux} = 24V_{av}$	$P_{aux}$	40			W
Driver and interface board	see separate technical information		3 x DR240			
Driver core			EiceDRIVER 2ED300C17-S			
Digital input level	resistor to GND 10,0k $\Omega$ , capacitor to GND 1nF, high = on, min 15mA	$V_{in}$	0,0		15,0	V
Digital output level	open collector, low = ok, max 15mA	$V_{out}$	0,0		15,0	V
Analog current outputs Unit 2	load max 1mA; at 750A	$V_{ana\ out}$	2,87	2,93	2,99	V
Analog DC Link voltage output	load max 1mA; at 1250V	$V_{DC\ out}$	8,67	8,85	9,03	V
Analog temperature output	load max 1mA; at $T_{NTC} = 73^{\circ}C$ correspond to $T_j = 125^{\circ}C$	$V_{T\ out}$	8,05	8,21	8,37	V
Overtemperature shutdown	at $T_{NTC} = 73^{\circ}C$ correspond to $T_j = 125^{\circ}C$	$V_{T\ out\ OT}$		8,21		V

### Heat sink water cooled / Thermal data

			min	typ	max	units
Water flow	according cooling water specification from infineon	$\Delta V/\Delta t_{Water}$	12			dm <sup>3</sup> /min
Water pressure drop		$\Delta p_{Water}$		550		mbar
Water pressure					8	bar
Cooling water inlet temperature		$T_{inlet}$	-40		50	$^{\circ}C$
Water connection				3/4		in

### IGBT data unit 2

			min	typ	max	units
Type	assumed					
collector-emitter saturation voltage	$I_c = 1200A; V_{ge} = 15V; T_{vj} = 125^{\circ}C$	$V_{CE\ sat}$		2,4		V
parameter for linear model	$T_{vj} = 25^{\circ}C$	$V_{ce1}$		1,1		V
parameter for linear model	$T_{vj} = 25^{\circ}C$	$r_{ce1}$		0,75		m $\Omega$
parameter for linear model	$T_{vj} = 125^{\circ}C$	$V_{ce2}$		1		V
parameter for linear model	$T_{vj} = 125^{\circ}C$	$r_{ce2}$		1,167		m $\Omega$
turn-on / turn-off energy loss per pulse	$T_{vj} = 25^{\circ}C$	$E_1$		240 / 305		mJ
turn-on / turn-off energy loss per pulse	$T_{vj} = 125^{\circ}C$	$E_2$		350 / 445		mJ
thermal resistance, junction to case	per IGBT	$R_{thjc}$		0,021		K/W
thermal resistance, case to heatsink	per IGBT	$R_{thch}$		0,017		K/W

prepared by: Hoelbe Oliver	date of publication: 2010-03-25
approved by: Marco Bohländer	revision: 2.0

# Technical Information

ModSTACK™ 6MS2400R17KE3-3WAH-I6C20VIN



## Vorläufige Daten preliminary data

### Diode data unit 2

			min	typ	max	units
Type	assumed					
forward voltage	$I_F = 1200A; V_{ge} = 0V; T_{vj} = 125^\circ C$	$V_F$		1,9		V
parameter for linear model	$T_{vj} = 25^\circ C$	$V_{F1}$		1,15		V
parameter for linear model	$T_{vj} = 25^\circ C$	$r_{F1}$		0,542		mΩ
parameter for linear model	$T_{vj} = 125^\circ C$	$V_{F2}$		1		V
parameter for linear model	$T_{vj} = 125^\circ C$	$r_{F2}$		0,75		mΩ
reverse recovery energy	$T_{vj} = 25^\circ C$	$E_{rec1}$		190		mJ
reverse recovery energy	$T_{vj} = 125^\circ C$	$E_{rec2}$		340		mJ
thermal resistance, junction to case	per Diode	$R_{thjc}$		0,048		K/W
thermal resistance, case to heatsink	per Diode	$R_{thch}$		0,039		K/W

### Environmental conditions

			min	typ	max	units
Storage temperature		$T_{stor}$	-40		65	°C
Ambient temperature		$T_{amb}$	-25		55	°C
Operating temperature	see chapter Heat sink water cooled / Thermal data					
Cooling air velocity (PCB and capacitor)		$V_{Air PCB}$	2,0			m/s
Air pressure	standard atmosphere	$p_{Air}$	900		1100	hPa
Humidity	no condensation	Rel. F	0		95	%
Installation height			0		1000	m
Vibration	according to EN60068				10	m/s <sup>2</sup>
Continuous vibration	according to EN60068				20	m/s <sup>2</sup>
Shock	according to EN60068				100	m/s <sup>2</sup>
Protection degree				IP00		
Pollution degree				2		
Dimensions	width × depth × height		1090	596	272	mm
Weight with heat sink	approximation			90,0		kg
Weight without heat sink	approximation			65,0		kg

prepared by: Hoelbe Oliver	date of publication: 2010-03-25
approved by: Marco Bohländer	revision: 2.0



Vorläufige Daten  
preliminary data

fo - derating curve IGBT (motor)  
cos(phi) = 0,95  
T<sub>cool medium</sub> = 50°C

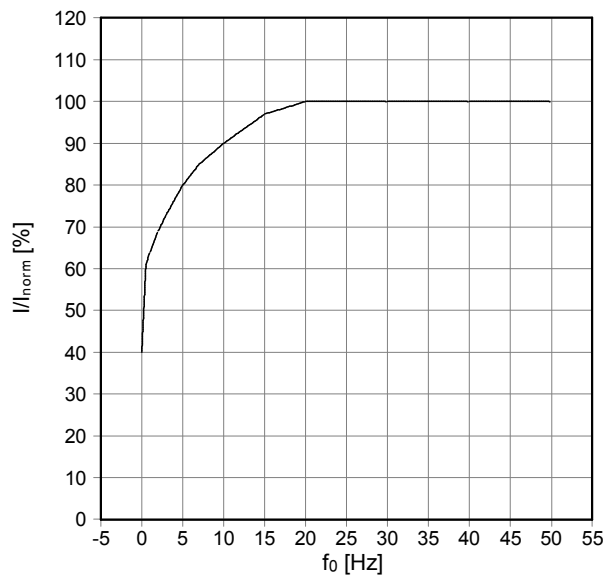

fsw - derating curve IGBT (motor)  
cos(phi) = 0,95  
T<sub>cool medium</sub> = 50°C

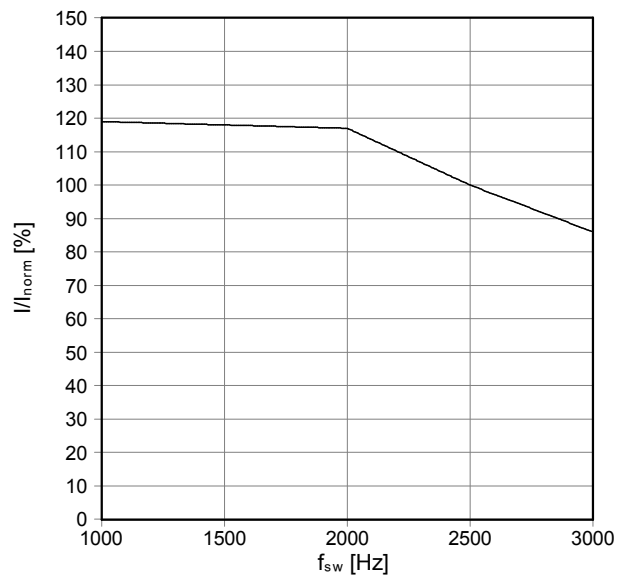

Transient thermal impedance per module  
T<sub>cool medium</sub> = 50°C

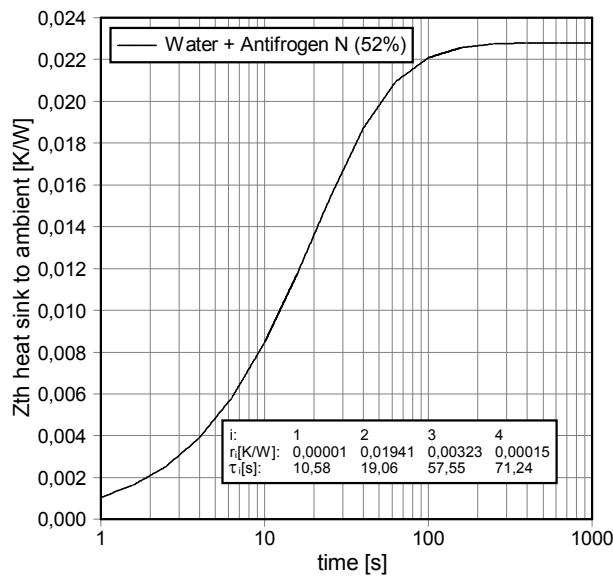

prepared by: Hoelbe Oliver	date of publication: 2010-03-25
approved by: Marco Böhländer	revision: 2.0

Circuit diagram

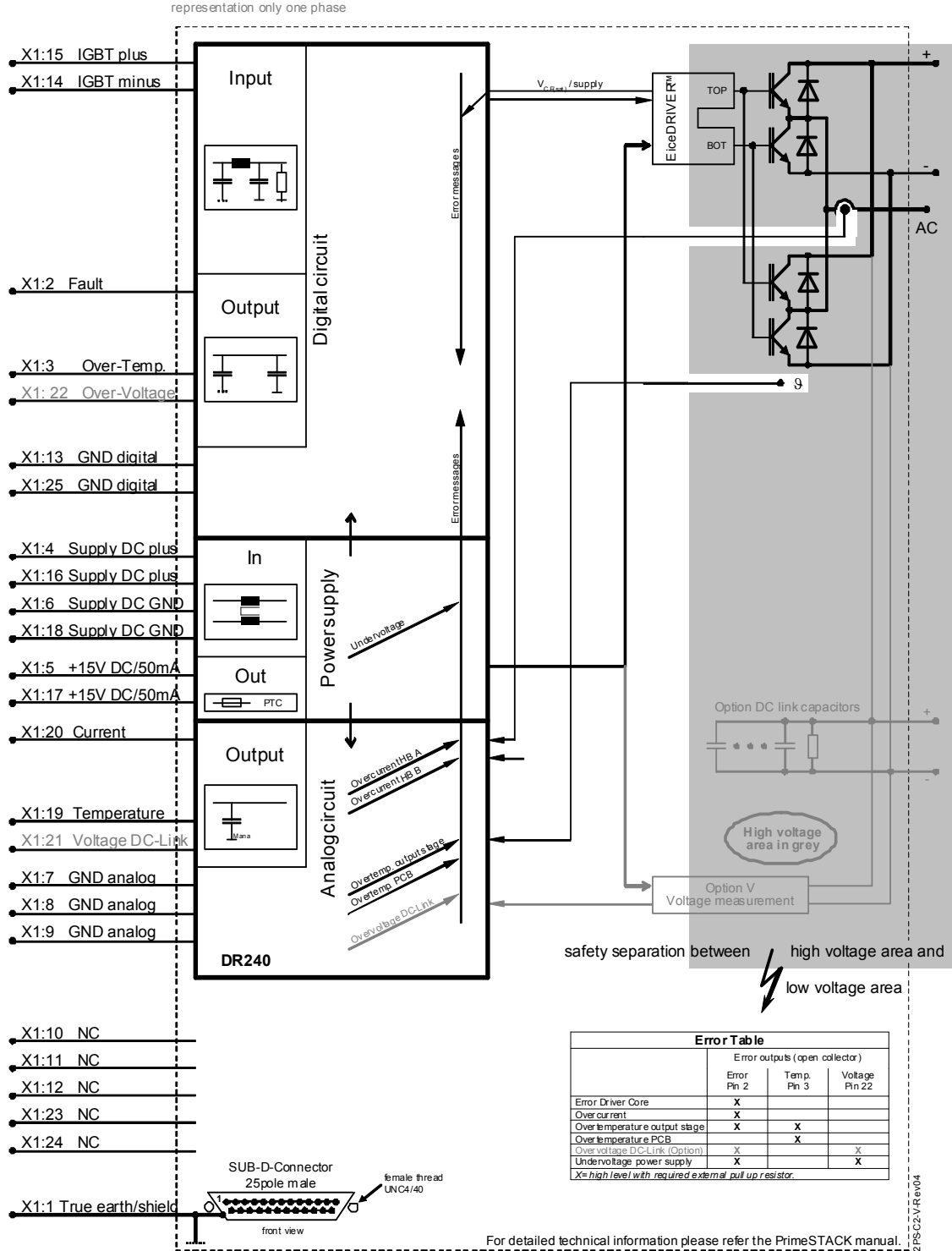

Error Table			
	Error outputs (open collector)		
	Error Pin 2	Temp. Pin 3	Voltage Pin 22
Error Driver Core	X		
Over current	X		
Over temperature output stage	X	X	
Over temperature PCB		X	
Over voltage DC-Link (Option)	X		X
Undervoltage power supply	X		X

X= high level with required external pull up resistor.

prepared by: Hoelbe Oliver	date of publication: 2010-03-25
approved by: Marco Böhländer	revision: 2.0

# Technical Information

ModSTACK™ 6MS2400R17KE3-3WAH-I6C20VIN



## Vorläufige Daten preliminary data

### Nutzungsbedingungen

Die in diesem Produktdatenblatt enthaltenen Daten sind ausschließlich für technisch geschultes Fachpersonal bestimmt. Die Beurteilung der Eignung dieses Produktes für Ihre Anwendung sowie die Beurteilung der Vollständigkeit der bereitgestellten Produktdaten für diese Anwendung obliegt Ihnen bzw. Ihren technischen Abteilungen.

In diesem Produktdatenblatt werden diejenigen Merkmale beschrieben, für die wir eine liefervertragliche Gewährleistung übernehmen. Eine solche Gewährleistung richtet sich ausschließlich nach Maßgabe der im jeweiligen Liefervertrag enthaltenen Bestimmungen. Garantien jeglicher Art werden für das Produkt und dessen Eigenschaften keinesfalls übernommen.

Sollten Sie von uns Produktinformationen benötigen, die über den Inhalt dieses Produktdatenblatts hinausgehen und insbesondere eine spezifische Verwendung und den Einsatz dieses Produktes betreffen, setzen Sie sich bitte mit dem für Sie zuständigen Vertriebsbüro in Verbindung (siehe [www.infineon.com](http://www.infineon.com), Vertrieb&Kontakt). Für Interessenten halten wir Application Notes bereit.

Aufgrund der technischen Anforderungen könnte unser Produkt gesundheitsgefährdende Substanzen enthalten. Bei Rückfragen zu den in diesem Produkt jeweils enthaltenen Substanzen setzen Sie sich bitte ebenfalls mit dem für Sie zuständigen Vertriebsbüro in Verbindung.

Sollten Sie beabsichtigen, das Produkt in Anwendungen der Luftfahrt, in gesundheits- oder lebensgefährdenden oder lebenserhaltenden Anwendungsbereichen einzusetzen, bitten wir um Mitteilung. Wir weisen darauf hin, dass wir für diese Fälle

- die gemeinsame Durchführung eines Risiko- und Qualitätsassessments;
- den Abschluss von speziellen Qualitätssicherungsvereinbarungen;
- die gemeinsame Einführung von Maßnahmen zu einer laufenden Produktbeobachtung dringend empfehlen und gegebenenfalls die Belieferung von der Umsetzung solcher Maßnahmen abhängig machen.

Soweit erforderlich, bitten wir Sie, entsprechende Hinweise an Ihre Kunden zu geben.

Inhaltliche Änderungen dieses Produktdatenblatts bleiben vorbehalten.

### Terms & Conditions of usage

The data contained in this product data sheet is exclusively intended for technically trained staff. You and your technical departments will have to evaluate the suitability of the product for the intended application and the completeness of the product data with respect to such application.

This product data sheet is describing the characteristics of this product for which a warranty is granted. Any such warranty is granted exclusively pursuant the terms and conditions of the supply agreement. There will be no guarantee of any kind for the product and its characteristics.

Should you require product information in excess of the data given in this product data sheet or which concerns the specific application of our product, please contact the sales office, which is responsible for you (see [www.infineon.com](http://www.infineon.com), sales&contact). For those that are specifically interested we may provide application notes.

Due to technical requirements our product may contain dangerous substances. For information on the types in question please contact the sales office, which is responsible for you.

Should you intend to use the Product in aviation applications, in health or live endangering or life support applications, please notify. Please note, that for any such applications we urgently recommend

- to perform joint Risk and Quality Assessments;
- the conclusion of Quality Agreements;
- to establish joint measures of an ongoing product survey, and that we may make delivery depended on the realization of any such measures.

If and to the extent necessary, please forward equivalent notices to your customers.

Changes of this product data sheet are reserved.

prepared by: Hoelbe Oliver	date of publication: 2010-03-25
approved by: Marco Bohländer	revision: 2.0

## Technical Information

ModSTACK™ 6MS2400R17KE3-3WAH-I6C20VIN



**Vorläufige Daten  
preliminary data**

### **Sicherheitshinweise**

Bevor Sie mit der Installation und dem Betrieb der Baugruppe beginnen, lesen Sie bitte sorgfältig alle Sicherheitshinweise, Warnungen und beachten Sie die angebrachten Warnschilder. Vergewissern Sie sich, dass alle Warnschilder in leserlichem Zustand verbleiben und fehlende oder beschädigte Schilder ersetzt werden.

### **Safety Instructions**

Prior to installation and operation, all safety notices and warnings and all warning signs attached to the equipment have to be carefully read. Make sure that all warning signs remain in a legible condition and that missing or damaged signs are replaced. To installation and operation, all safety notices and warnings and all warning signs attached to the equipment have to be carefully read. Make sure that all warning signs remain in a legible condition and that missing or damaged signs are replaced.

prepared by: Hoelbe Oliver	date of publication: 2010-03-25
approved by: Marco Bohlländer	revision: 2.0



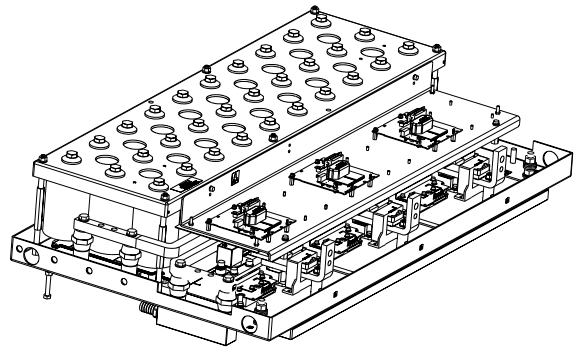
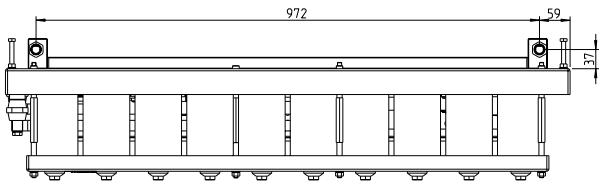
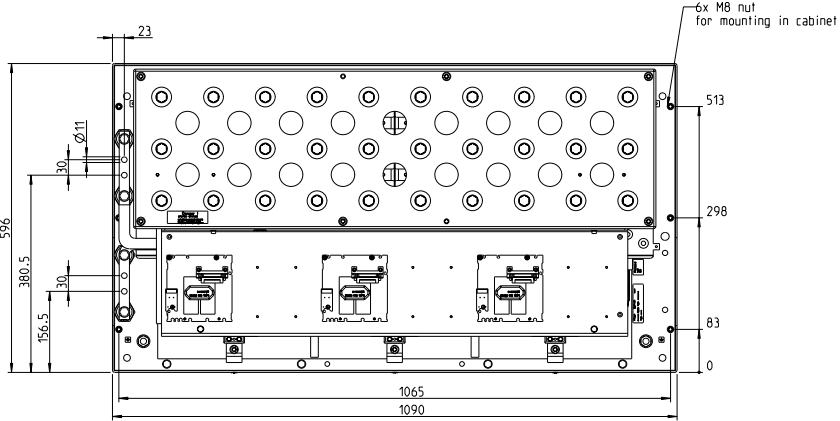
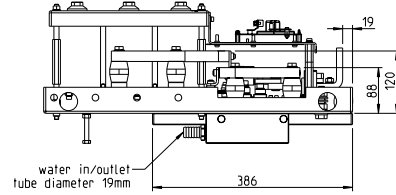
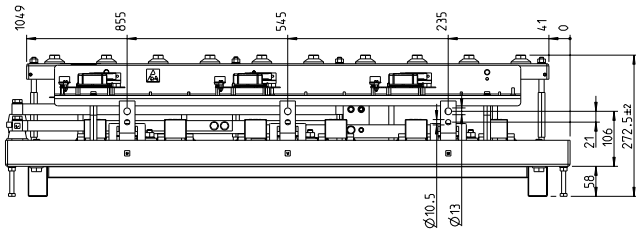

Part-No. 33847	general	Interaxx	Surface	Scale 1:5
Assembly-No.				
	Agent	08.06.2009	Meier	Description Outline MS3 6MSxx00Rxx xxx-3W AH-Cxx
	Checked by	08.06.2009	van Boven	
	Drawn			
				Graph-No. 33847
				Version 0
				Sheet 1/2
				Constructed for A2
01	K. Blumenthal	05.08.09	Po	
Vers.	Revision	Date	Name	Origin