

MIPAQ™ sense Modul in Sixpack-Konfiguration mit Trench/Feldstopp IGBT4, Emitter Controlled 4 Diode und Strommesswiderstand mit integriertem  $\Sigma/\Delta$ -Wandler und galvanisch getrennter digitalen Schnittstelle  
MIPAQ™ sense module in Sixpack-configuration with trench/fieldstop IGBT4, emitter controlled 4 diode and current sense shunt with integrated  $\Sigma/\Delta$ -converter and galvanical isolation of the digital interface

**Kenndaten**  
**key data**

Topologie topology	B6I
Halbleiter-Nenndaten rated semiconductor data	1200V, 75A
Art der Belastung load type	ohmsch-induktiv resistive-inductive
Zielanwendung target application	Industrieantriebe, USV, Klimatisierungsgeräte, Solarumrichter industrial drives, UPS, Air conditioning, Solar inverters
Sensoren sensors	Strommesswiderstände für Laststrom, NTC für Bodenplattentemperatur shunts for output current, NTC for baseplate temperature
Digitale Schnittstelle digital interface	5V-CMOS, galvanische Trennung nach IEC61800-5-1 5V-CMOS, galvanic isolation according to IEC61800-5-1
Normen standards	IEC61800-5-1 (Overvoltage Category III, Pollution Degree 2, Insulating Material Gruppe II), UL94, RoHs

**Blockschaltbild**  
**block diagram**

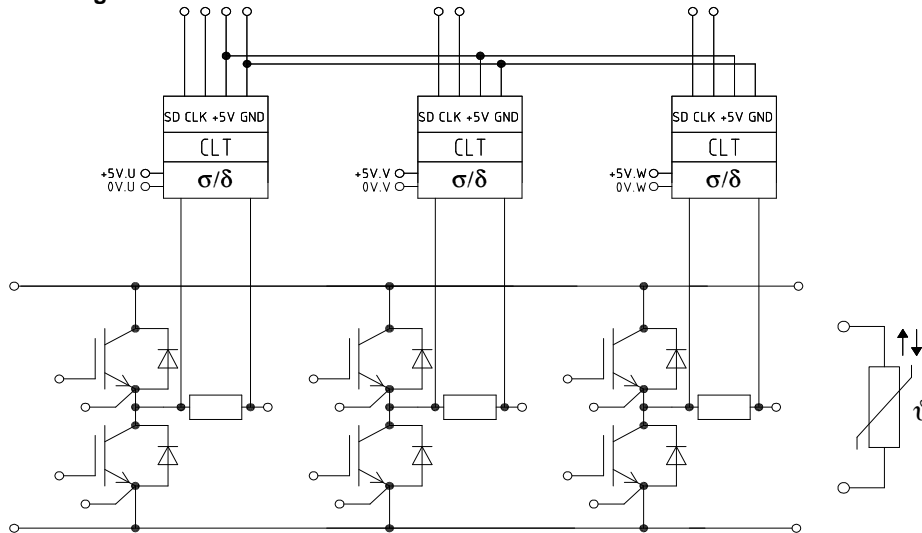

**Foto**  
**photo**

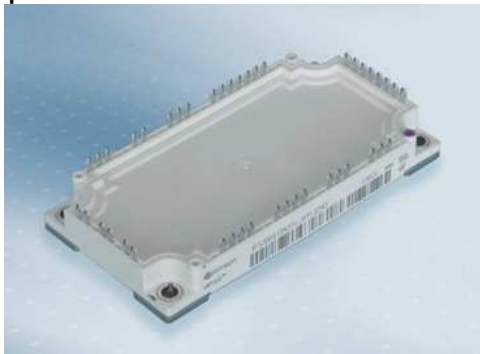

prepared by: US	date of publication: 16.08.2011
approved by: MH	revision: 2.1

# Technische Information / technical information

IGBT-Module  
IGBT-modules

## IFS75S12N3T4\_B11



### IGBT-Wechselrichter / IGBT-inverter

### Zieldaten / target data

#### Höchstzulässige Werte / maximum rated values

Kollektor-Emitter-Sperrspannung collector-emitter voltage	$T_{vj} = 25^{\circ}\text{C}$	$V_{CES}$	1200	V
Kollektor-Dauergleichstrom DC-collector current	$T_C = 95^{\circ}\text{C}, T_{vj} = 175^{\circ}\text{C}$	$I_{C, nom}$	75	A
Periodischer Kollektor Spitzenstrom repetitive peak collector current	$t_p = 1 \text{ ms}$	$I_{CRM}$	150	A
Gesamt-Verlustleistung total power dissipation	$T_C = 25^{\circ}\text{C}, T_{vj} = 175^{\circ}\text{C}$	$P_{tot}$	349	W
Gate-Emitter-Spitzenspannung gate-emitter peak voltage		$V_{GES}$	+/-20	V

#### Charakteristische Werte / characteristic values

min. typ. max.

Kollektor-Emitter Sättigungsspannung collector-emitter saturation voltage	$I_C = 75 \text{ A}, V_{GE} = 15 \text{ V}, T_{vj} = 25^{\circ}\text{C}$ $I_C = 75 \text{ A}, V_{GE} = 15 \text{ V}, T_{vj} = 125^{\circ}\text{C}$ $I_C = 75 \text{ A}, V_{GE} = 15 \text{ V}, T_{vj} = 150^{\circ}\text{C}$	$V_{CE sat}$	1,85 2,15 2,25	2,15	V
Gate-Schwellenspannung gate threshold voltage	$I_C = 4,00 \text{ mA}, V_{CE} = V_{GE}, T_{vj} = 25^{\circ}\text{C}$	$V_{GE(th)}$	5,2	5,8	6,4
Gateladung gate charge	$V_{GE} = -15 \text{ V} \dots +15 \text{ V}$	$Q_G$	0,57		$\mu\text{C}$
Interner Gatewiderstand internal gate resistor	$T_{vj} = 25^{\circ}\text{C}$	$R_{Gint}$	10		$\Omega$
Eingangskapazität input capacitance	$f = 1 \text{ MHz}, T_{vj} = 25^{\circ}\text{C}, V_{CE} = 25 \text{ V}, V_{GE} = 0 \text{ V}$	$C_{ies}$	4,30		nF
Rückwirkungskapazität reverse transfer capacitance	$f = 1 \text{ MHz}, T_{vj} = 25^{\circ}\text{C}, V_{CE} = 25 \text{ V}, V_{GE} = 0 \text{ V}$	$C_{res}$	0,16		nF
Kollektor-Emitter Reststrom collector-emitter cut-off current	$V_{CE} = 1200 \text{ V}, V_{GE} = 0 \text{ V}, T_{vj} = 25^{\circ}\text{C}$	$I_{CES}$		1,0	mA
Gate-Emitter Reststrom gate-emitter leakage current	$V_{CE} = 0 \text{ V}, V_{GE} = 20 \text{ V}, T_{vj} = 25^{\circ}\text{C}$	$I_{GES}$		100	nA
Einschaltverzögerungszeit (ind. Last) turn-on delay time (inductive load)	$I_C = 75 \text{ A}, V_{CE} = 600 \text{ V}, T_{vj} = 25^{\circ}\text{C}$ $V_{GE} = \pm 15 \text{ V}, T_{vj} = 125^{\circ}\text{C}$ $R_{Gon} = 2,2 \Omega, T_{vj} = 150^{\circ}\text{C}$	$t_{don}$	0,135 0,15 0,152		$\mu\text{s}$
Anstiegszeit (induktive Last) rise time (inductive load)	$I_C = 75 \text{ A}, V_{CE} = 600 \text{ V}, T_{vj} = 25^{\circ}\text{C}$ $V_{GE} = \pm 15 \text{ V}, T_{vj} = 125^{\circ}\text{C}$ $R_{Gon} = 2,2 \Omega, T_{vj} = 150^{\circ}\text{C}$	$t_r$	0,036 0,042 0,045		$\mu\text{s}$
Abschaltverzögerungszeit (ind. Last) turn-off delay time (inductive load)	$I_C = 75 \text{ A}, V_{CE} = 600 \text{ V}, T_{vj} = 25^{\circ}\text{C}$ $V_{GE} = \pm 15 \text{ V}, T_{vj} = 125^{\circ}\text{C}$ $R_{Goff} = 2,2 \Omega, T_{vj} = 150^{\circ}\text{C}$	$t_{doff}$	0,33 0,38 0,42		$\mu\text{s}$
Fallzeit (induktive Last) fall time (inductive load)	$I_C = 75 \text{ A}, V_{CE} = 600 \text{ V}, T_{vj} = 25^{\circ}\text{C}$ $V_{GE} = \pm 15 \text{ V}, T_{vj} = 125^{\circ}\text{C}$ $R_{Goff} = 2,2 \Omega, T_{vj} = 150^{\circ}\text{C}$	$t_f$	0,108 0,190 0,222		$\mu\text{s}$
Einschaltverlustenergie pro Puls turn-on energy loss per pulse	$I_C = 75 \text{ A}, V_{CE} = 600 \text{ V}, T_{vj} = 25^{\circ}\text{C}$ $V_{GE} = \pm 15 \text{ V}, di/dt = 2,4 \text{ kA}/\mu\text{s} (T_{vj} = 150^{\circ}\text{C}), T_{vj} = 125^{\circ}\text{C}$ $R_{Goff} = 2,2 \Omega, T_{vj} = 150^{\circ}\text{C}$	$E_{on}$	4,87 7,7 8,92		mJ
Abschaltverlustenergie pro Puls turn-off energy loss per pulse	$I_C = 75 \text{ A}, V_{CE} = 600 \text{ V}, T_{vj} = 25^{\circ}\text{C}$ $V_{GE} = \pm 15 \text{ V}, du_{CE}/dt = 3,3 \text{ kV}/\mu\text{s} (T_{vj} = 150^{\circ}\text{C}), T_{vj} = 125^{\circ}\text{C}$ $R_{Goff} = 2,2 \Omega, T_{vj} = 150^{\circ}\text{C}$	$E_{off}$	4,76 7,16 7,95		mJ
Kurzschlußverhalten SC Data	$V_{GE} \leq 15 \text{ V}, V_{CC} = 800 \text{ V}$ $V_{CEmax} = V_{CES} - L_{sCE} \cdot di/dt, t_p \leq 10 \mu\text{s}, T_{vj} \leq 150^{\circ}\text{C}$	$I_{SC}$	270		A
Innerer Wärmewiderstand thermal resistance, junction to case	pro IGBT / per IGBT	$R_{thJC}$	0,43		K/W
Übergangs-Wärmewiderstand thermal resistance, case to heatsink	pro IGBT / per IGBT $\lambda_{Paste} = 1 \text{ W}/(\text{m}^2\text{K}) / \lambda_{grease} = 1 \text{ W}/(\text{m}^2\text{K})$	$R_{thCH}$	0,195		K/W

prepared by: US	date of publication: 16.08.2011
approved by: MH	revision: 2.1

**Zieldaten**  
**Target Data**

**Diode-Wechselrichter / diode-inverter**

**Höchstzulässige Werte / maximum rated values**

Periodische Spitzenspernschaltung repetitive peak reverse voltage	$T_{vj} = 25^{\circ}\text{C}$	$V_{RRM}$	1200	V
Dauergleichstrom DC forward current		$I_F$	75	A
Periodischer Spitzenstrom repetitive peak forw. current	$t_p = 1 \text{ ms}$	$I_{FRM}$	150	A
Grenzlastintegral $I^2t$ - value	$V_R = 0\text{V}, t_p = 10\text{ms}, T_{vj} = 125^{\circ}\text{C}$ $V_R = 0\text{V}, t_p = 10\text{ms}, T_{vj} = 150^{\circ}\text{C}$	$I^2t$	960 960	A <sup>2</sup> s A <sup>2</sup> s
Spitzenverlustleistung maximum power dissipation	$T_C = 25^{\circ}\text{C}, T_{vj} = 175^{\circ}\text{C}$	$P_{ROM}$	217	W

**Charakteristische Werte / characteristic values**

min. typ. max.

Durchlaßspannung forward voltage	$I_F = 75 \text{ A}, V_{GE} = 0\text{V}, T_{vj} = 25^{\circ}\text{C}$	$V_F$		1,70	2,15	V
	$I_F = 75 \text{ A}, V_{GE} = 0\text{V}, T_{vj} = 125^{\circ}\text{C}$			1,65		V
	$I_F = 75 \text{ A}, V_{GE} = 0\text{V}, T_{vj} = 150^{\circ}\text{C}$			1,65		V
Rückstromspitze peak reverse recovery current	$I_F = 75 \text{ A}, -di_F/dt = 2,9 \text{ kA}/\mu\text{s} (T_{vj} = 150^{\circ}\text{C}), T_{vj} = 25^{\circ}\text{C}$	$I_{RM}$		91		A
	$V_R = 600\text{V}, T_{vj} = 125^{\circ}\text{C}$			98		A
	$V_{GE} = -15\text{V}, T_{vj} = 150^{\circ}\text{C}$			105		A
Sperrverzögerungsladung recovered charge	$I_F = 75 \text{ A}, -di_F/dt = 2,9 \text{ kA}/\mu\text{s} (T_{vj} = 150^{\circ}\text{C}), T_{vj} = 25^{\circ}\text{C}$	$Q_r$		8,2		$\mu\text{C}$
	$V_R = 600\text{V}, T_{vj} = 125^{\circ}\text{C}$			13,8		$\mu\text{C}$
	$V_{GE} = -15\text{V}, T_{vj} = 150^{\circ}\text{C}$			15,5		$\mu\text{C}$
Abschaltnenergie pro Puls reverse recovery energy	$I_F = 75 \text{ A}, -di_F/dt = 2,9 \text{ kA}/\mu\text{s} (T_{vj} = 150^{\circ}\text{C}), T_{vj} = 25^{\circ}\text{C}$	$E_{rec}$		4,8		mJ
	$V_R = 600\text{V}, T_{vj} = 125^{\circ}\text{C}$			6,9		mJ
	$V_{GE} = -15\text{V}, T_{vj} = 150^{\circ}\text{C}$			7,7		mJ
Innerer Wärmewiderstand thermal resistance, junction to case	pro Diode / per diode	$R_{thJC}$		0,69		K/W
Übergangs-Wärmewiderstand thermal resistance, case to heatsink	pro Diode / per diode $\lambda_{Paste} = 1 \text{ W}/(\text{m}^2\text{K}) / \lambda_{Grease} = 1 \text{ W}/(\text{m}^2\text{K})$	$R_{thCH}$		0,31		K/W

**Strommesswiderstand / shunt**

**Charakteristische Werte / characteristic values**

min. typ. max.

Nennwiderstand rated resistance	$25^{\circ}\text{C} < T_{shunt} < 200^{\circ}\text{C}$	$R_{25}$	2,376	2,40	2,424	m $\Omega$
Temperaturkoeffizient temperature coefficient (tcr)	$20^{\circ}\text{C} - 60^{\circ}\text{C}$	$\vartheta_{CR}$		< 30		ppm/K
Betriebstemperatur Strommesswiderstand operation temperature shunt		$T_{vop}$			200	$^{\circ}\text{C}$
Innerer Wärmewiderstand; thermal resistance, junction to case		$R_{thJC}$		13,0		K/W

prepared by: US	date of publication: 16.08.2011
approved by: MH	revision: 2.1

# Technische Information / technical information

IGBT-Module  
IGBT-Modules

## IFS75S12N3T4\_B11



### Zieldaten Target Data

#### NTC-Widerstand / NTC-thermistor

##### Charakteristische Werte / characteristic values

			min.	typ.	max.	
Nennwiderstand rated resistance	$T_C = 25^\circ\text{C}$	$R_{25}$		5,00		k $\Omega$
Abweichung von $R_{100}$ deviation of $R_{100}$	$T_C = 100^\circ\text{C}; R_{100} = 493 \Omega$	$\Delta R/R$	-5		5	%
Verlustleistung power dissipation	$T_C = 25^\circ\text{C}$	$P_{25}$			20,0	mW
B-Wert B-value	$R_2 = R_{25} \exp [B(1/T_2 - 1/(298,15\text{K}))]$	$B_{25/50}$		3375		K
B-Wert B-value	$R_2 = R_{25} \exp [B(1/T_2 - 1/(298,15\text{K}))]$	$B_{25/80}$		3411		K
B-Wert B-value	$R_2 = R_{25} \exp [B(1/T_2 - 1/(298,15\text{K}))]$	$B_{25/100}$		3433		K

Angaben gemäß gültiger Application Note.  
Specification according to the valid application note.

#### Modul / module

			min.	typ.	max.	
Isolations-Prüfspannung insulation test voltage	RMS, $f = 50 \text{ Hz}$ , $t = 1 \text{ min}$	$V_{\text{ISOL}}$		2,5		kV
Material Modulgrundplatte material of module baseplate				CU		
Material für innere Isolation material for internal insulation				$\text{Al}_2\text{O}_3$		
Kriechstrecke creepage distance	Kontakt - Kühlkörper / Kontakt - Kontakt terminal to heatsink / terminal to terminal	$d_{\text{creepage}}$		10		mm
Luftstrecke clearance	Kontakt - Kühlkörper / Kontakt - Kontakt terminal to heatsink / terminal to terminal	$d_{\text{clearance}}$		7,5		mm
Vergleichszahl der Kriechwegbildung comperative tracking index		CTI		> 200		

			min.	typ.	max.	
Übergangs-Wärmewiderstand thermal resistance, case to heatsink	pro Modul / per module $\lambda_{\text{Paste}} = 1 \text{ W/(m}^2\text{K)} / \lambda_{\text{Greese}} = 1 \text{ W/(m}^2\text{K)}$	$R_{\text{thCH}}$		0,011		K/W
Modulinduktivität stray inductance module		$L_{\text{sCE}}$		22		nH
Modulleitungs-widerstand, Anschlüsse - Chip module lead resistance, terminals - chip	$T_C = 25^\circ\text{C}$ , pro Schalter / per switch (Rshunt ist inklusive / Rshunt is inclusiv)	$R_{\text{CC+EE}}$		1,2		m $\Omega$
Höchstzulässige Sperrschichttemperatur maximum junction temperature	Wechselrichter inverter	$T_{\text{vj max}}$			175	$^\circ\text{C}$
Temperatur im Schaltbetrieb temperature under switching conditions	Wechselrichter inverter	$T_{\text{vj op}}$	-40		150	$^\circ\text{C}$
Zulässige Gehäuse-Betriebstemperatur allowed operation case temperature	Bodenplatte / Kontakt base plate / contact	$T_{\text{c op}}$	-40		125	$^\circ\text{C}$
Lagertemperatur storage temperature		$T_{\text{stg}}$	-40		125	$^\circ\text{C}$
Anzugsdrehmoment f. mech. Befestigung mounting torque	Schraube M5 - Montage gem. gültiger Applikation Note screw M5 - mounting according to valid application note	M	3,00	-	6,00	Nm
Gewicht weight		G		316		g

prepared by: US	date of publication: 16.08.2011
approved by: MH	revision: 2.1

# Technische Information / technical information

IGBT-Module  
IGBT-Modules

## IFS75S12N3T4\_B11



### Zieldaten Target Data

#### Sigma-Delta-Wandlereinheit / sigma-delta converter unit

#### Charakteristische Werte / characteristic values

$V_{CC1} = 4.75 \text{ V bis } / \text{ to } 5.25 \text{ V}$ ,  $V_{CC2} = 4.5 \text{ V bis } / \text{ to } 5.5 \text{ V}$ ,  $T_C = 105^\circ\text{C}$  sofern nicht anders spezifiziert / unless otherwise noted.

			min.	typ.	max.	
Maximale Phasenstromfrequenz maximum line current frequency	Phase / phase U, V, W	$f_{SYS}$			30,0	kHz
Maximale periodische Isolationsspannung I maximum repetitive isolation voltage I	Logik (SD/CLK) gegen Lastausgänge logik (SD/CLK) to terminals	$V_{IORM}$			1420	V
Maximale periodische Isolationsspannung II maximum repetitive isolation voltage II	Leistungshalbleiter gegen Bodenplatte (f = 50Hz, t = 1min) power semiconductor to base plate (f = 50Hz, t = 1min)	$V_{ISOL}$			2500	V
Spannungsflankensteilheitsfestigkeit voltage slope immunity	$V_{IMV} = 500\text{V}$ zwischen GND und 0V.U, 0V.V bzw. 0V.W $V_{IMV} = 500\text{V}$ between GND and 0V.U, 0V.V, 0V.W, respectively	d/dt $V_{slope}$			50	kV/ $\mu\text{s}$
Höchste zulässige Überspannung highest allowable overvoltage	Zwischen GND und 0V.U, 0V.V bzw. 0V.W Between GND and 0V.U, 0V.V, 0V.W, respectively	$V_{OVTM}$			6000	V
Maximale Stoßisolationsspannung maximum surge isolation voltage	Zwischen GND und 0V.U, 0V.V bzw. 0V.W Between GND and 0V.U, 0V.V, 0V.W, respectively	$V_{ISOM}$			6000	V
Isolationswiderstand isolation resistance	$V_{IMV} = 500\text{V}$ zwischen GND und 0V.U, 0V.V bzw. 0V.W $V_{IMV} = 500\text{V}$ between GND and 0V.U, 0V.V, 0V.W, respectively	$R_{IO}$	1			G $\Omega$
Maximaler Wechselrichter Ausgangsstrom für höchstmögliche Auflösung maximum inverter output current for highest resolution	Phase / phase U, V, W	$I_{M,max,high\_res}$	-133,3	-	+133,3	A
Maximaler Wechselrichter Ausgangsstrom für lineares Wandlerverhalten maximum inverter output current for linear converter behavior	Phase / phase U, V, W	$I_{M,max,linear}$	-83,3	-	+133,3	A
Tastverhältnis des Ausgangs SD bei 0 A Wechselrichter Ausgangsstrom duty cycle of output SD at 0 A inverter output current	$T_C = 25^\circ\text{C}$ ; $I_M = 0 \text{ A}$ ; Phase / phase U, V, W	$PDM_{ZERO}$	49,6	50,0	50,4	%
Tastverhältnis des Ausgangs SD bei max. positivem Wechselrichter Ausgangsstrom duty cycle of output SD at max. positive inverter output current	$T_C = 25^\circ\text{C}$ ; $I_M > 133,3 \text{ A}$ ; Phase / phase U, V, W	$PDM_{POS}$		100,0		%
Tastverhältnis des Ausgangs SD bei max. negativem Wechselrichter Ausgangsstrom duty cycle of output SD at max. negative inverter output current	$T_C = 25^\circ\text{C}$ ; $I_M < -133,3 \text{ A}$ ; Phase / phase U, V, W	$PDM_{NEG}$		0,0		%
Differentieller Verstärkungsfehler differential gain error	Bedingung: Shunt-Spannungsabfall bis Pin SD conditions: shunt voltage drop to Pin SD	$\Delta G$	-1,56	-	1,56	%
Gleichstrom-Versatz vom Strommesswiderstand zum Ausgang SD DC offset from internal shunt to Pin SD	Bedingung: $I_M = 0 \text{ A}$ , siehe auch Diagramme $\Delta PDM = f(T_a)$ und $\Delta PDM = f(V_{CC1})$ conditions: $I_M = 0 \text{ A}$ , see also diagrams $\Delta PDM = f(T_a)$ and $\Delta PDM = f(V_{CC1})$	$PDM_{DC\_offset}$	-	-	0,4	%PDM
Temperaturdrift des Gleichstrom-Versatz vom Strommesswiderstand zum Ausgang SD DC offset drift due to temperature from shunt to Pin SD	Bedingung: $I_M = 0 \text{ A}$ , siehe Diagramm $\Delta PDM = f(T_a)$ conditions: $I_M = 0 \text{ A}$ , see diagram $\Delta PDM = f(T_a)$	$PDM_{DC\_offset, T_a}$	0,09	-	0,135	%PDM
Versorgungsspannungsdrift ( $V_{dss1}$ ) des Gleichstrom-Versatz vom Strommesswiderstand zum Ausgang SD DC Offset drift due to $V_{dss1}$ from shunt to Pin SD	Bedingung: $I_M = 0 \text{ A}$ , siehe Diagramm $\Delta PDM = f(V_{CC1})$ conditions: $I_M = 0 \text{ A}$ , see diagram $\Delta PDM = f(V_{CC1})$	$PDM_{DC\_offset, V_{dss1}}$	0,116	-	0,15	%PDM
Effektive Anzahl der Bits (ENOB Auflösung) effective number of bits (ENOB resolution)	Phase U, V, W Bedingungen: $I_M = [-83,3\text{A}; +83,3\text{A}]$ , $f(I_M) = 1\text{kHz}$ , siehe Diagramm ENOB = $f(T_a)$ phase U, V, W conditions: $I_M = [-83,3\text{A}; +83,3\text{A}]$ , $f(I_M) = 1\text{kHz}$ , see diagram ENOB = $f(T_a)$	ENOB	10	12		bit
Signal-Rausch-Abstand signal-to-noise ratio	Phase U, V, W Bedingungen: $I_M = [-83,3\text{A}; +83,3\text{A}]$ , $f(I_M) = 1\text{kHz}$ , siehe Diagramm SNR = $f(T_a)$ phase U, V, W conditions: $I_M = [-83,3\text{A}; +83,3\text{A}]$ , $f(I_M) = 1\text{kHz}$ , see diagram SNR = $f(T_a)$	SNR	65	74		dB
Gesamtklirrfaktor total harmonic distortion	Phase U, V, W Bedingungen: $I_M = [-83,3\text{A}; +83,3\text{A}]$ , $f(I_M) = 1\text{kHz}$ , siehe Diagramm THD = $f(T_a)$ phase U, V, W conditions: $I_M = [-83,3\text{A}; +83,3\text{A}]$ , $f(I_M) = 1\text{kHz}$ , see diagram THD = $f(T_a)$	THD	65	72		dB

<sup>1)</sup> = Erklärung von PDM%: 100% = alle Pulse sind '1', 0% = alle Pulse sind '0', 50% = 50% für jeweils '1' und '0' am Ausgangs-Pin SD.

<sup>1)</sup> = explanation of PDM%: 100% = all '1', 0% = all '0', 50% = 50% for both '1' and '0' at output pin SD.

prepared by: US	date of publication: 16.08.2011
approved by: MH	revision: 2.1

# Technische Information / technical information

IGBT-Module  
IGBT-Modules

## IFS75S12N3T4\_B11



### Zieldaten Target Data

			min.	typ.	max.	
Versorgungsspannung Shuntseite supply voltage shunt side	Phase / phase U, V, W	$V_{CC1U,V,W}$	4,75	5,00	5,25	V
Versorgungsspannung Logikteil supply voltage logic section		$V_{CC2}$	4,5	5,0	5,5	V
Maximaler Stromverbrauch Leistungsteil maximal current consumption power section	Phase / phase U, V, W	$I_{CC1U,V,W}$		22	32	mA
Maximaler Stromverbrauch Logikteil maximal current consumption logic section		$I_{CC2}$		15	19	mA
$V_{CC1U,V,W}$ Unterspannungserkennungsschwelle $V_{CC1U,V,W}$ undervoltage detection threshold	Betriebszustand status: operating	$V_{UVLOH1}$		4,3	4,4	V
$V_{CC1U,V,W}$ Unterspannungserkennungsschwelle $V_{CC1U,V,W}$ undervoltage detection threshold	Unterspannungsfehlerzustand status: undervoltage fault	$V_{UVLOL1}$	3,9	4,1		V
Hysteresis ( $V_{UVLOH1} - V_{UVLOL1}$ ) hysteresis ( $V_{UVLOH1} - V_{UVLOL1}$ )		$V_{HYST1}$	0,1	0,2		V
$V_{CC2}$ Unterspannungserkennungsschwelle $V_{CC2}$ undervoltage detection	Betriebszustand status: operating	$V_{UVLOH2}$		4,0	4,3	V
$V_{CC2}$ Unterspannungserkennungsschwelle $V_{CC2}$ undervoltage detection threshold	Unterspannungsfehlerzustand status: undervoltage fault	$V_{UVLOL2}$	3,5	3,7		V
Hysteresis ( $V_{UVLOH2} - V_{UVLOL2}$ ) hysteresis ( $V_{UVLOH2} - V_{UVLOL2}$ )		$V_{HYST2}$	0,2	0,3		V

### Digital-Ausgang / digital output

$V_{CE1} = 4.75$  V bis / to 5.25 V,  $V_{CE2} = 4.5$  V bis / to 5.5 V,  $T_C = 105^\circ\text{C}$  sofern nicht anders spezifiziert / unless otherwise noted.

			min.	typ.	max.	
Ausgangsspannung Low-Pegel: CLK output voltage low: CLK	@ $V_{CC2} = 4.5\text{V}$ und / and $I_O = 4\text{mA}$ Belastung / load	$V_{OCLK,low}$		0,12	0,26	V
Ausgangsspannung High-Pegel: CLK output voltage high: CLK	@ $V_{CC2} = 4.5\text{V}$ und / and $I_O = 4\text{mA}$ Belastung / load	$V_{OCLK,high}$	4,48	4,8		V
Ausgangslaststrom Pull-down: CLK output load current pull-down: CLK	Modus / in mode: pull-down	$I_{OCLK,low}$		-22		mA
Ausgangslaststrom Pull-up: CLK output load current pull-up: CLK	Modus / in mode: pull-up	$I_{OCLK,high}$		14,5		mA
Ausgangsflankensteilheit, steigend: CLK rising output slope: CLK	Lastkapazität / load capacitance $C_L = 50\text{pF}$	$t_{CLKRT}$		1,16		ns
Ausgangsflankensteilheit, fallend: CLK falling output slope: CLK	Lastkapazität / load capacitance $C_L = 50\text{pF}$	$t_{CLKFT}$		1,16		ns
Ausgangsspannung Low-Pegel: SD output voltage low: SD	@ $V_{CC2} = 4.5\text{V}$ und $I_O = 4\text{mA}$ load, valid at falling edge of CLK	$V_{OSD,low}$		0,17	0,26	V
Ausgangsspannung High-Pegel: SD output voltage high: SD	@ $V_{CC2} = 4.5\text{V}$ und $I_O = 4\text{mA}$ load, valid at falling edge of CLK	$V_{OSD,high}$	3,98	4,3		V
Ausgangslaststrom Pull-down: SD output load current pull-down: SD	Modus / in mode: pull-down	$I_{OSD,low}$		-22		mA
Ausgangslaststrom Pull-up: SD output load current pull-up: SD	Modus / in mode: pull-up	$I_{OSD,high}$		14,5		mA
Ausgangsflankensteilheit, steigend: SD rising output slope: SD	Lastkapazität / load capacitance $C_L = 50\text{pF}$	$t_{SDRT}$		1,16		ns
Ausgangsflankensteilheit, fallend: SD falling output slope: SD	Lastkapazität / load capacitance $C_L = 50\text{pF}$	$t_{SDFT}$		1,16		ns
Taktfrequenz: CLK clock frequency: CLK		$f_{CLK}$	9,3	10,0	10,5	MHz
Tastverhältnis Takt High-Pegel: CLK duty cycle clock high: CLK	$T_{CLK} = 1/f_{CLK}$	$t_{CLKH}/T_{CLK}$	20	30	40	%
Daten Einrichtezeit vor steigender Takt-Flanke CLK data setup time prior to rising edge of CLK clock		$t_{SDS}$	10	25		ns
Daten Haltezeit nach fallender Takt-Flanke CLK data hold time after falling edge of CLK clock		$t_{SDH} = t_{CLK} - t_{SDS}$	40	50		ns
Jitter: CLK jitter: CLK	short term, cycle to cycle jitter	$\Delta t_{CLK}$		1,3	4,5	ns
Anstiegszeit steigende Takt-Flanke: CLK rising edge time of clock: CLK		$t_{CLKRT}$	0,5	1,5	2,5	ns
Abfallzeit fallende Takt-Flanke: CLK falling edge time of clock: CLK		$t_{CLKFT}$	0,5	1,5	2,5	ns
Anstiegszeit steigende Daten-Flanke: SD rising edge time of data: SD		$t_{SDRT}$	0,5	1,5	2,5	ns
Abfallzeit fallende Daten-Flanke: SD falling edge time of data: SD		$t_{SDFT}$	0,5	1,5	2,5	ns
CLK-Anlaufzeit nach Anlegen der Versorgungsspannung first CLK after power-up	oscillator output delivers pulses	$\Delta t_{CLKpulses}$		250		ns

prepared by: US	date of publication: 16.08.2011
approved by: MH	revision: 2.1

Taktdiagramm Modulator Ausgang / timing diagram modulator output

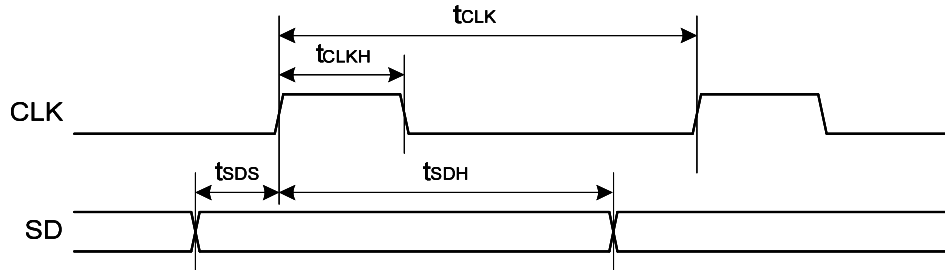

Taktdiagramm Anstiegs- / Fallzeit CLK-Ausgang / timing diagram rise / fall time output CLK

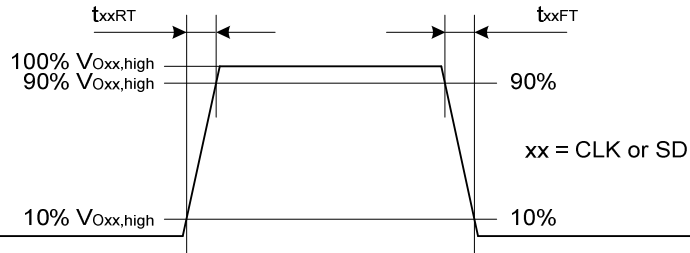

Taktdiagramm Jitter / timing diagram jitter

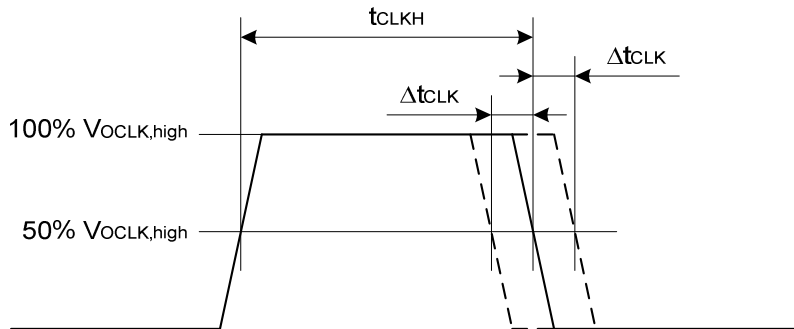

DC-Offset  $\Sigma/\Delta$ -Wandler (typisch)  
dc offset  $\Sigma/\Delta$  converter (typical)  
 $\Delta PDM = f(T_a)$   
 $V_{CC1} = 5V$

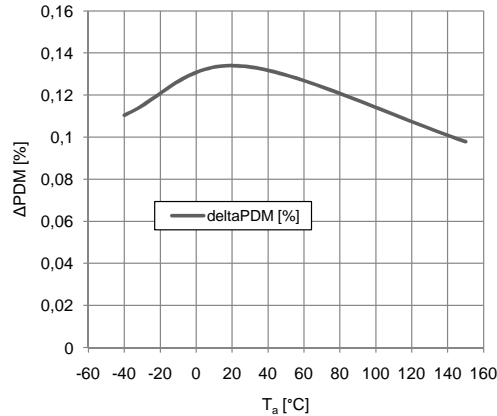

DC-Offset  $\Sigma/\Delta$ -Wandler (typisch)  
dc offset  $\Sigma/\Delta$  converter (typical)  
 $\Delta PDM = f(V_{CC1})$   
 $T_a = 25^\circ C$

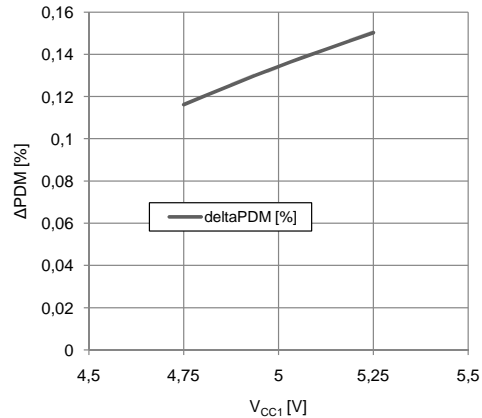

prepared by: US	date of publication: 16.08.2011
approved by: MH	revision: 2.1

**Zieldaten**  
**Target Data**

ENOB  $\Sigma/\Delta$ -Wandler (typisch)  
ENOB  $\Sigma/\Delta$  converter (typical)  
ENOB = f(Ta)  
VCC1 = 5V

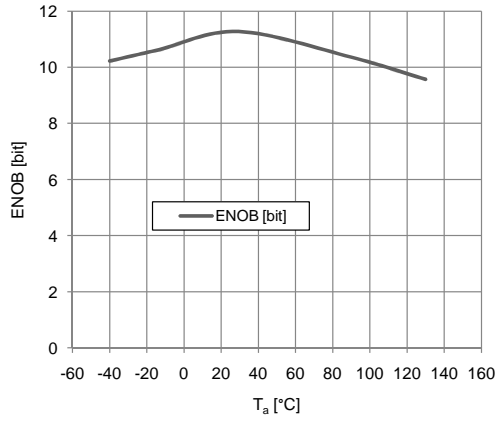

SNR  $\Sigma/\Delta$ -Wandler (typisch)  
SNR  $\Sigma/\Delta$  converter (typical)  
SNR = f(Ta)  
VCC1 = 5V

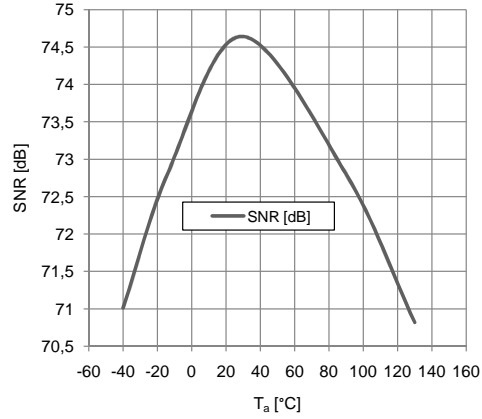

THD  $\Sigma/\Delta$ -Wandler (typisch)  
THD  $\Sigma/\Delta$  converter (typical)  
THD = f(Ta)  
VCC1 = 5V

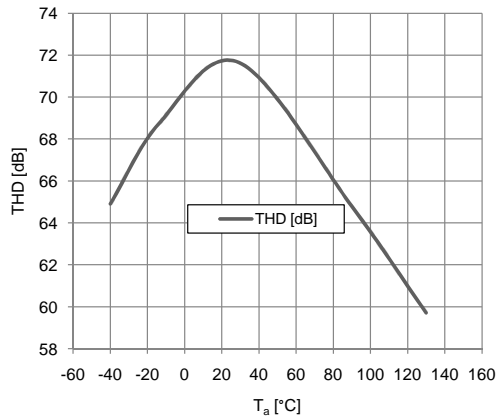

fCLK  $\Sigma/\Delta$ -Wandler (typisch)  
fCLK  $\Sigma/\Delta$  converter (typical)  
fCLK = f(Ta)  
VCC1 = 5V

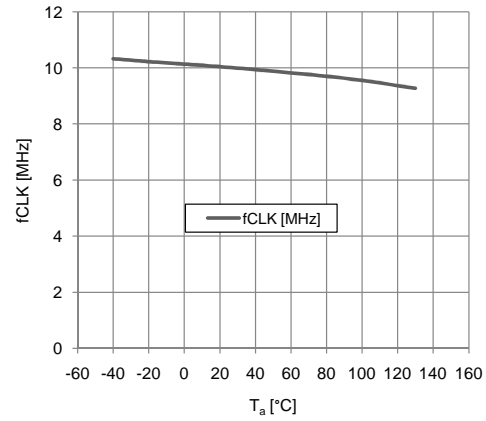

prepared by: US	date of publication: 16.08.2011
approved by: MH	revision: 2.1



**Zieldaten**  
**Target Data**

Ausgangskennlinie IGBT-Wechselr. (typisch)  
output characteristic IGBT inverter (typical)  
 $I_C = f(V_{CE})$   
 $V_{GE} = 15V$

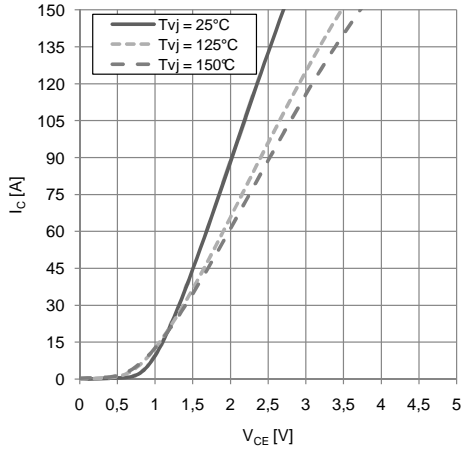

Ausgangskennlinienfeld IGBT-Wechselr. (typisch)  
output characteristic IGBT inverter (typical)  
 $I_C = f(V_{CE})$   
 $T_{vj} = 150^\circ C$

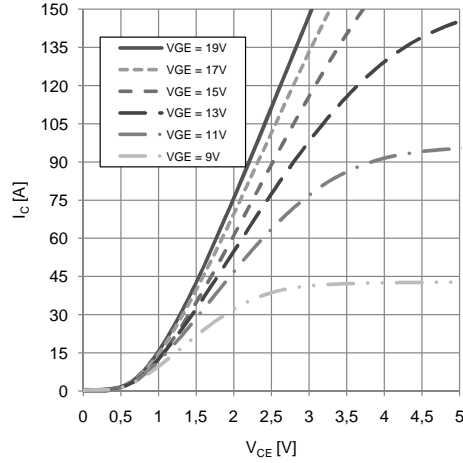

Übertragungscharakteristik IGBT-Wechselr. (typisch)  
transfer characteristic IGBT inverter (typical)  
 $I_C = f(V_{GE})$   
 $V_{CE} = 20V$

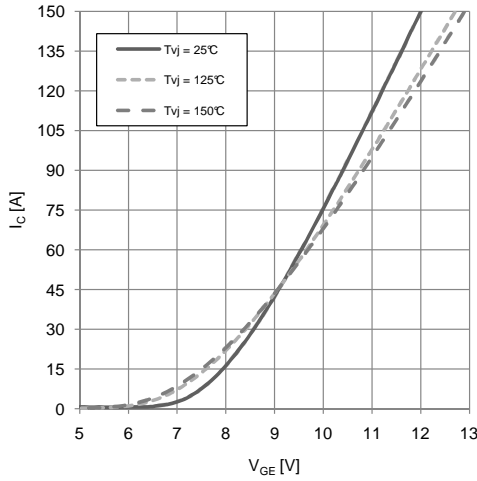

Einschaltverluste IGBT-Wechselr. (typisch)  
turn-on switching losses IGBT inverter (typical)  
 $E_{on} = f(I_C)$   
 $V_{ge} = \pm 15V, R_{gon} = 2.2\Omega, V_{ce} = 600V$

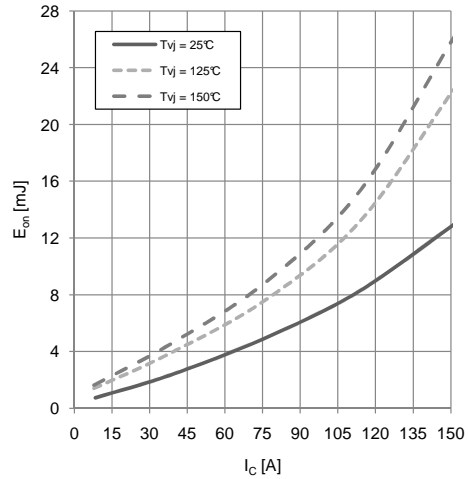

Ausschaltverluste IGBT-Wechselr. (typisch)  
turn-off switching losses IGBT inverter (typical)  
 $E_{off} = f(I_C)$   
 $V_{GE} = \pm 15V, R_{Goff} = 2.2\Omega$

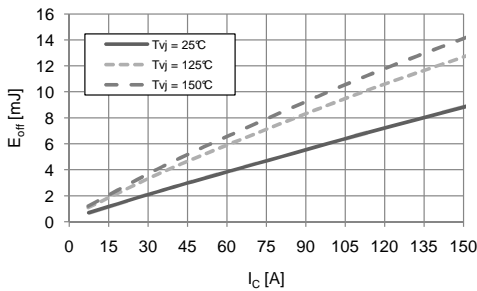

Schaltverluste IGBT-Wechselr. (typisch)  
switching losses IGBT inverter (typical)  
 $E_{on} = f(R_G), E_{off} = f(R_G)$   
 $V_{GE} = \pm 15V, I_C = 75A$

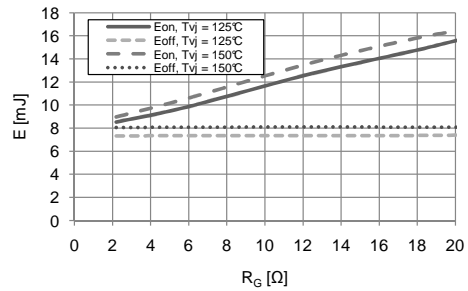

prepared by: US	date of publication: 16.08.2011
approved by: MH	revision: 2.1

**Zieldaten**  
**Target Data**

**Transienter Wärmewiderstand IGBT-Wechsel.**  
**transient thermal impedance IGBT-inverter**  
 $Z_{thJC} = f(t)$

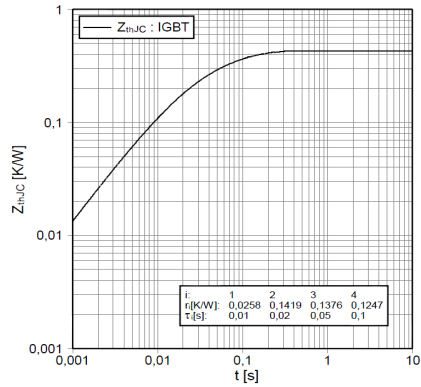

Sicherer Rückwärts-Arbeitsbereich IGBT-Wr. (RBSOA)  
reverse bias safe operating area IGBT inverter (RBSOA)  
 $I_c = f(V_{ce})$   
 $V_{GE} = \pm 15V, R_{goff} = 2.2\Omega, T_{vj} = 150^\circ C$

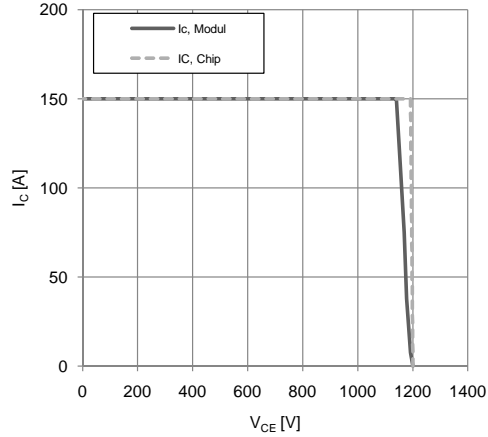

**Durchlasskennlinie der Diode-Wechselr. (typisch)**  
**forward characteristic of diode inverter (typical)**  
 $I_F = f(V_F)$

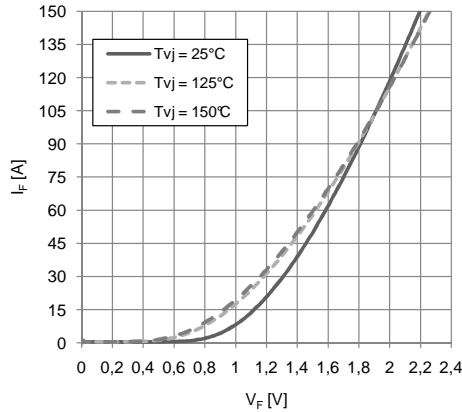

**Schaltverluste Diode-Wechselr. (typisch)**  
**switching losses diode inverter (typical)**  
 $E_{rec} = f(I_F)$   
 $V_{GE} = \pm 15V, R_{Gon} = 2.2\Omega, V_{CE} = 600V$

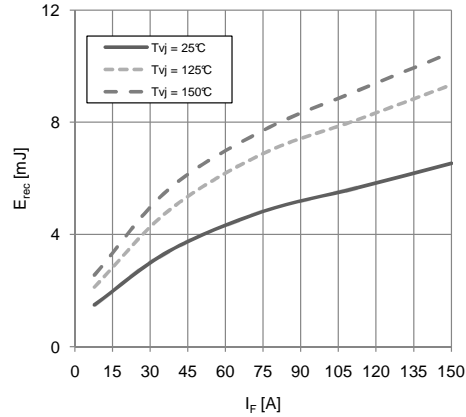

**Schaltverluste Diode-Wechselr. (typisch)**  
**switching losses diode inverter (typical)**  
 $E_{rec} = f(R_G)$   
 $V_{GE} = \pm 15V, I_F = 75A, V_{CE} = 600V$

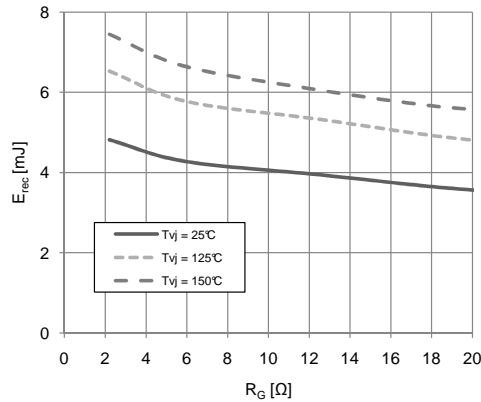

**Transienter Wärmewiderstand Diode-Wechselr.**  
**transient thermal impedance diode-inverter**  
 $Z_{thJC} = f(t)$

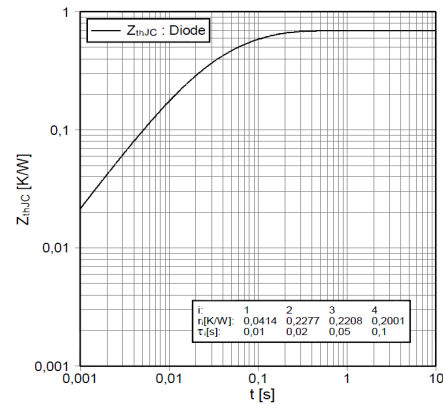

prepared by: US	date of publication: 16.08.2011
approved by: MH	revision: 2.1

Zieldaten  
Target Data

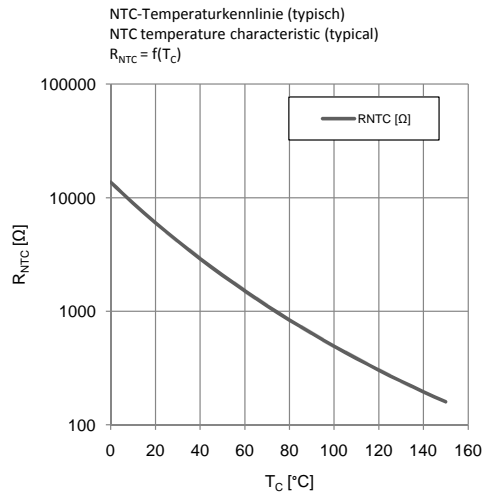

prepared by: US	date of publication: 16.08.2011
approved by: MH	revision: 2.1

Zieldaten  
Target Data

Schaltplan / circuit diagram

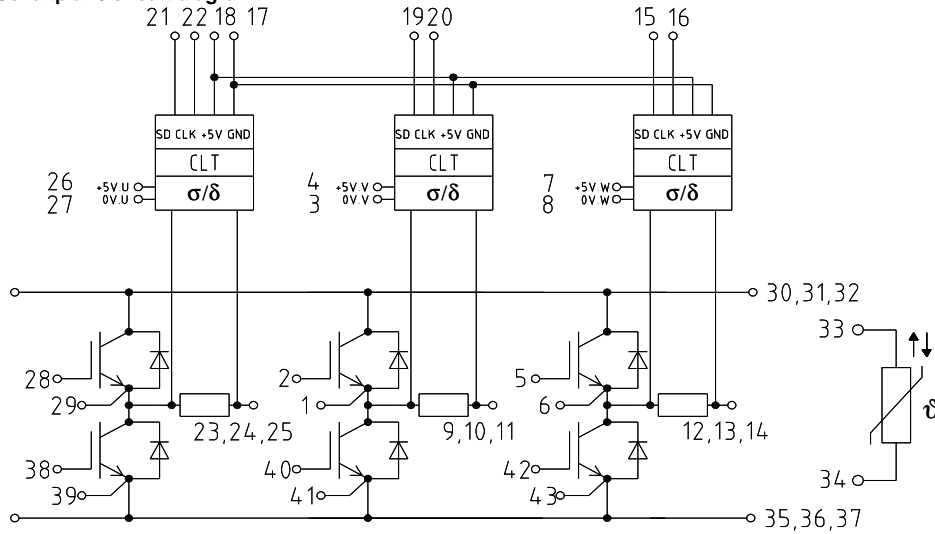

Gehäuseabmessungen / package outline

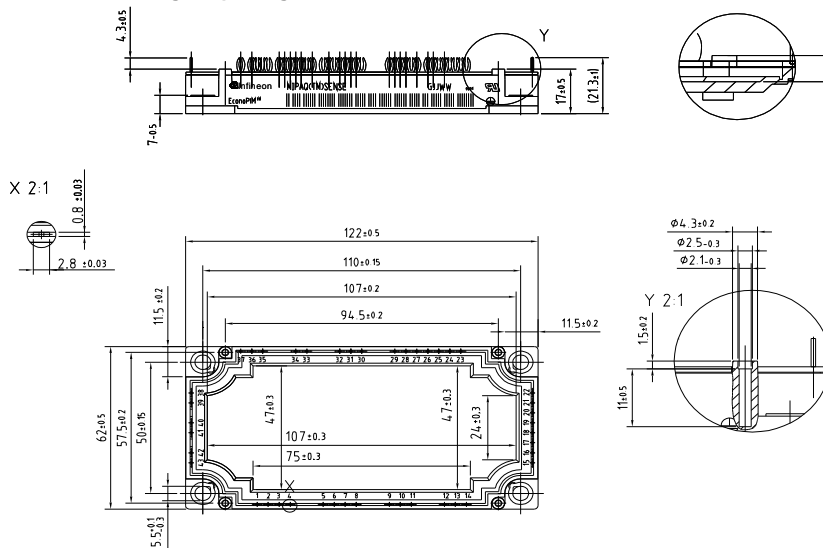

PCB Hole pattern

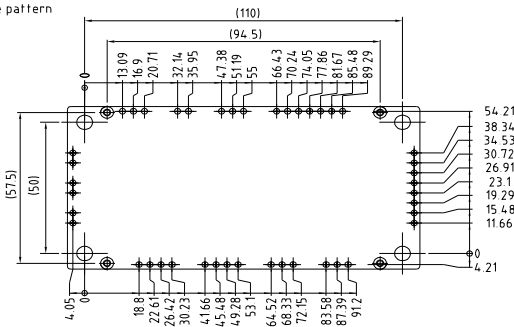

- Tolerance of PCB hole pattern  $\pm 0.1$
- Hole specification for contacts see AN 2007-09
- Diameters of plated holes  $\varnothing 2.14\text{mm} - 2.29\text{mm}$
- Diameters of drill  $\varnothing 2.35\text{mm}$

prepared by: US	date of publication: 16.08.2011
approved by: MH	revision: 2.1



**Zieldaten**  
**Target Data**

**Nutzungsbedingungen**

Die in diesem Produktdatenblatt enthaltenen Daten sind ausschließlich für technisch geschultes Fachpersonal bestimmt. Die Beurteilung der Eignung dieses Produktes für Ihre Anwendung sowie die Beurteilung der Vollständigkeit der bereitgestellten Produktdaten für diese Anwendung obliegt Ihnen bzw. Ihren technischen Abteilungen.

In diesem Produktdatenblatt werden diejenigen Merkmale beschrieben, für die wir eine liefervertragliche Gewährleistung übernehmen. Eine solche Gewährleistung richtet sich ausschließlich nach Maßgabe der im jeweiligen Liefervertrag enthaltenen Bestimmungen. Garantien jeglicher Art werden für das Produkt und dessen Eigenschaften keinesfalls übernommen.

Sollten Sie von uns Produktinformationen benötigen, die über den Inhalt dieses Produktdatenblatts hinausgehen und insbesondere eine spezifische Verwendung und den Einsatz dieses Produktes betreffen, setzen Sie sich bitte mit dem für Sie zuständigen Vertriebsbüro in Verbindung (siehe [www.infineon.com](http://www.infineon.com), Vertrieb&Kontakt). Für Interessenten halten wir Application Notes bereit.

Aufgrund der technischen Anforderungen könnte unser Produkt gesundheitsgefährdende Substanzen enthalten. Bei Rückfragen zu den in diesem Produkt jeweils enthaltenen Substanzen setzen Sie sich bitte ebenfalls mit dem für Sie zuständigen Vertriebsbüro in Verbindung.

Sollten Sie beabsichtigen, das Produkt in Anwendungen der Luftfahrt, in gesundheits- oder lebensgefährdenden oder lebenserhaltenden Anwendungsbereichen einzusetzen, bitten wir um Mitteilung. Wir weisen darauf hin, dass wir für diese Fälle

- die gemeinsame Durchführung eines Risiko- und Qualitätsassessments;
- den Abschluss von speziellen Qualitätssicherungsvereinbarungen;
- die gemeinsame Einführung von Maßnahmen zu einer laufenden Produktbeobachtung dringend empfehlen und gegebenenfalls die Belieferung von der Umsetzung solcher Maßnahmen abhängig machen.

Soweit erforderlich, bitten wir Sie, entsprechende Hinweise an Ihre Kunden zu geben.

Inhaltliche Änderungen dieses Produktdatenblatts bleiben vorbehalten.

**terms & conditions of usage**

The data contained in this product data sheet is exclusively intended for technically trained staff. You and your technical departments will have to evaluate the suitability of the product for the intended application and the completeness of the product data with respect to such application.

This product data sheet is describing the characteristics of this product for which a warranty is granted. Any such warranty is granted exclusively pursuant the terms and conditions of the supply agreement. There will be no guarantee of any kind for the product and its characteristics.

Should you require product information in excess of the data given in this product data sheet or which concerns the specific application of our product, please contact the sales office, which is responsible for you (see [www.infineon.com](http://www.infineon.com), sales&contact). For those that are specifically interested we may provide application notes.

Due to technical requirements our product may contain dangerous substances. For information on the types in question please contact the sales office, which is responsible for you.

Should you intend to use the Product in aviation applications, in health or live endangering or life support applications, please notify. Please note, that for any such applications we urgently recommend

- to perform joint Risk and Quality Assessments;
- the conclusion of Quality Agreements;
- to establish joint measures of an ongoing product survey,

and that we may make delivery depended on the realization of any such measures.

If and to the extent necessary, please forward equivalent notices to your customers.

Changes of this product data sheet are reserved.

prepared by: US	date of publication: 16.08.2011
approved by: MH	revision: 2.1