

Fast Switching SCR T607_18

175A Avg.
(275 RMS)
Up to 1200 Volts
10-50 μ s

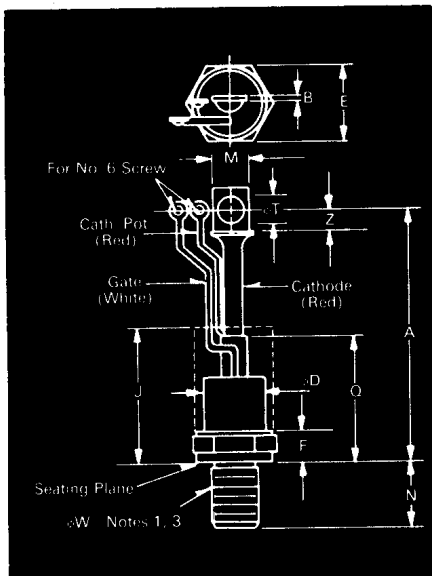

Conforms to TO-93 Outline

Features:

- Center fire, di/dynamic gate
- High di/dt with soft gate control
- High frequency operation
- Sinusoidal waveform operation to 20 KHz
- Rectangular waveform operation to 20 KHz
- Low dynamic forward voltage drop
- Low switching losses at high frequency
- Westinghouse Lifetime Guarantee

Symbol	Inches		Millimeters	
	Min.	Max.	Min.	Max.
A	7.750	8.100	196.85	205.74
A ₁	7.750	8.100	196.85	205.74
B	.063	.172	1.60	4.37
φD	.980	1.090	24.89	27.69
E	1.212	1.250	30.78	31.75
F	.250	.630	6.35	16.00
J	3.25		82.55	
M	.530	.755	13.46	19.18
N	1.040	1.077	26.42	27.36
Q		2.250		57.15
φT	.260	.290	6.60	7.37
Z	.340		8.64	
φW	¼-16 UNF-2A			

Creep Distance—.75 in. min. (19.05 mm).
Strike Distance—.69 in. min. (17.53 mm).
(In accordance with NEMA standards.)

Finish—Nickel Plate.
Approx. Weight—8 oz. (227 g).

1. Complete threads to extend to within 2½ threads of seating plane.
2. Angular orientation of terminals is undefined.
3. Pitch diameter of ¼-16 UNF-2A (coated) threads (ASA B1.1—1960).
4. Dimension "J" denotes seated height with leads bent at right angles.

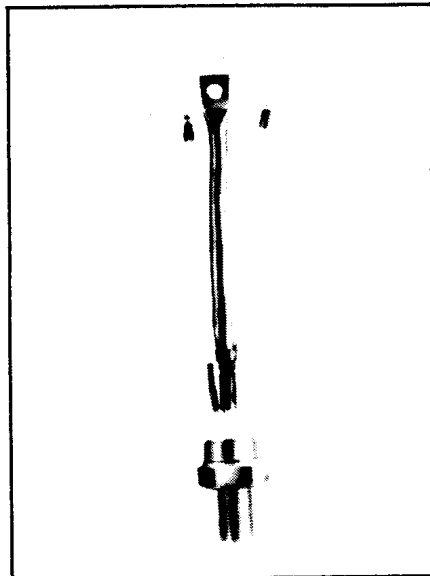

Applications:

- Inverters for UPS
- AC motor control
- Induction heating
- Cycloconverters
- Choppers

Ordering Information

Type	Voltage		Current		Turn-off		Gate Current		Leads	
Code	V _{DRM} and V _{RRM} (V)	Code	I _{T(av)} (A)	Code	t _q μ sec	Code	I _{GT} (ma)	Code	Case	Code
T607	100	01	175	18	10	5	150	4	TO-93	BT
	200	02			15					
	300	03			20					
	400	04			25					
	500	05			30					
	600	06			40					
	700	07			50					
	800	08								
	900	09								
	1000	10								
	1100	11								
	1200	*12								

Example

Obtain optimum device performance for your application by selecting proper Order Code.

Type T 607 rated at 175A average with V_{DRM} = 1000V, I_{GT} = 150 ma, t_q = 30 μ sec and standard flex lead — order as

*for 10 μ sec turn-off, consult factory

Type	Voltage	Current	Turn Off	Gate Current	Leads
T 6 0 7	1 0	1 8	5	4	B T

FAST SWITCHING THYRISTORS

175A Avg.
(275 RMS)
Up to 1200 Volts
10-50 μ s

Fast Switching
SCR
T607__18

Voltage

Blocking State Maximums ^② ($T_J = 125^\circ\text{C}$)

	Symbol	100	200	300	400	500	600	700	800	900	1000	1100	1200
Repetitive peak forward blocking voltage, V	V_{DRM}	100	200	300	400	500	600	700	800	900	1000	1100	1200
Repetitive peak reverse voltage, V	V_{RRM}	100	200	300	400	500	600	700	800	900	1000	1100	1200
Non-repetitive transient peak reverse voltage, $t \leq 5.0$ m sec, V	V_{RSM}	200	300	400	500	600	700	800	900	1000	1100	1200	1300
Forward leakage current, mA peak	I_{DRM}	← 25 →											
Reverse leakage current, mA peak	I_{RRM}	← 25 →											

Current

Conducting State Maximums
($T_J = 125^\circ\text{C}$)

	Symbol	T607__18
RMS forward current, A	$I_T(\text{rms})$	275
Ave. forward current, A	$I_T(\text{av})$	175
One-half cycle surge current ^③ , A	I_{TSM}	4500
I^2t for fusing (for times ≥ 8.3 ms), $\text{A}^2\text{-sec}$	I^2t	84,000
Forward voltage drop at $I_{TM} = 625\text{A}$ and $T_J = 25^\circ\text{C}$, V	V_{TM}	1.85
Min. repetitive di/dt ^{①④⑤} , A/ μ sec	di/dt	300

Switching

($T_J = 25^\circ\text{C}$)

	Symbol	
Max. turn-off time, $I_T = 150\text{A}$, $T_J = 125^\circ\text{C}$, $di/dt = 12.5$ A/ μ sec, reappplied $dv/dt = 20\text{V}/\mu$ sec linear to .8V V_{DRM} , μ sec ^{④⑤}	t_q	10 to 50
Typ. turn-on-time, $I_T = 100\text{A}$, $V_D = 100\text{V}$ ^④ , μ sec	t_{on}	3.5
Min. critical dv/dt , exponential to V_{DRM} , $T_J = 125^\circ\text{C}$, V/ μ sec ^{②⑤}	dv/dt	300
Min. di/dt non-repetitive, ^{①④⑤} , A/ μ sec	di/dt	800

Gate

Maximum Parameters
($T_J = 25^\circ\text{C}$)

	Symbol	
Gate current to trigger at $V_D = 12\text{V}$, mA	I_{GT}	150
Gate voltage to trigger at $V_D = 12\text{V}$, V	V_{GT}	3
Non-triggering gate voltage, $T_J = 125^\circ\text{C}$, and rated V_{DRM} , V	V_{GDM}	0.15
Peak forward gate current, A	I_{GTM}	4
Peak reverse gate voltage, V	V_{GRM}	5
Peak gate power, Watts	P_{GM}	16
Average gate power, Watts	$P_{G(av)}$	3

Thermal and Mechanical

	Symbol	
Min., Max. oper. junction temp., $^\circ\text{C}$	T_J	-40 to +125
Min., Max. storage temp., $^\circ\text{C}$	T_{stg}	-40 to +150
Max. mounting torque, in lb. ^①		300
Max. Thermal resistance ^①		
Junction to case, $^\circ\text{C}/\text{Watt}$	$R_{\theta JC}$.13
Case to sink, lubricated, $^\circ\text{C}/\text{Watt}$	$R_{\theta CS}$.08

- ① Consult recommended mounting procedures.
- ② Applies for zero or negative gate bias.
- ③ Per JEDEC RS-397, 5.2.2.1.
- ④ With recommended gate drive.
- ⑤ Higher dv/dt ratings available, consult factory.
- ⑥ Per JEDEC standard RS-397, 5.2.2.6.
- ⑦ For operation with antiparallel diode, consult factory.

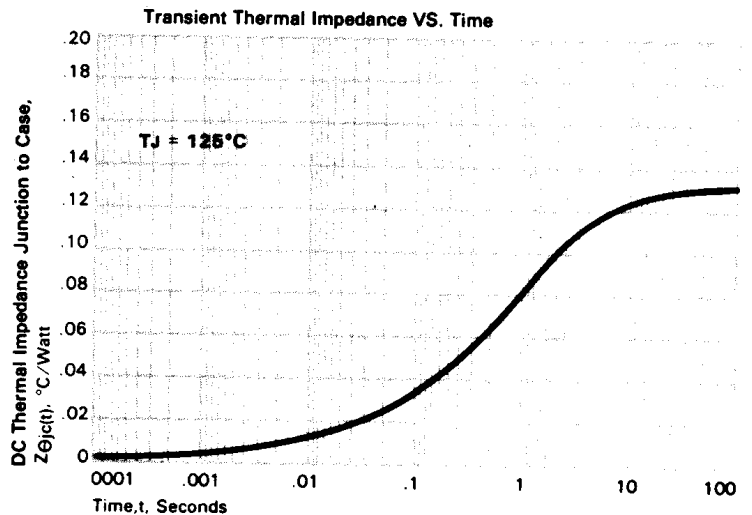
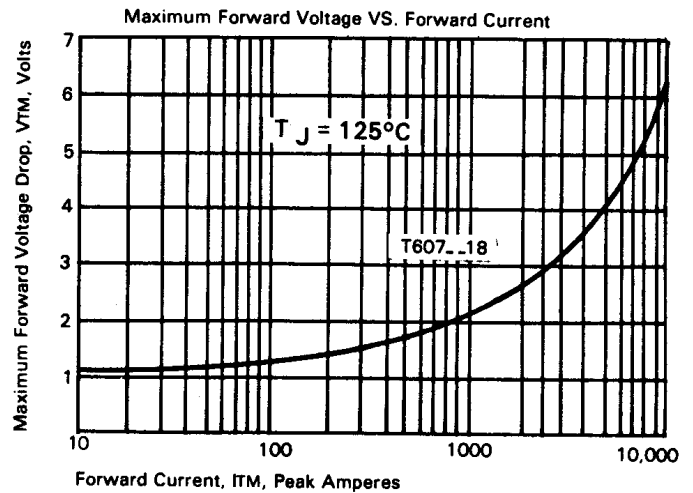

FAST SWITCHING THYRISTORS

Fast Switching SCR T607-18

175A Avg.
(275 RMS)
Up to 1200 Volts
10-50 μ s

Sinusoidal Current Data

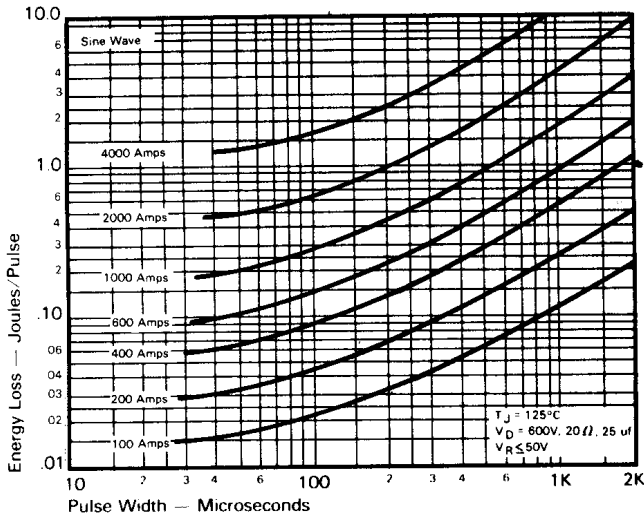

ENERGY PER PULSE FOR SINUSOIDAL PULSES

Trapezoidal Wave Current Data

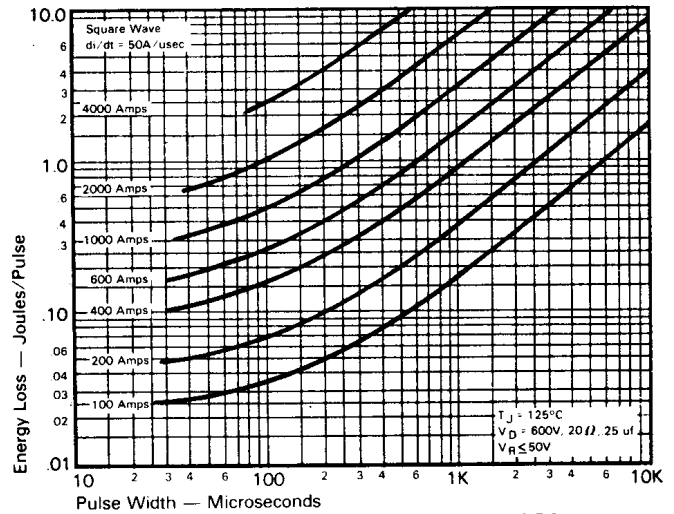

ENERGY PER PULSE FOR TRAPEZOIDAL PULSES
($di/dt = 50\text{A/usec}$)

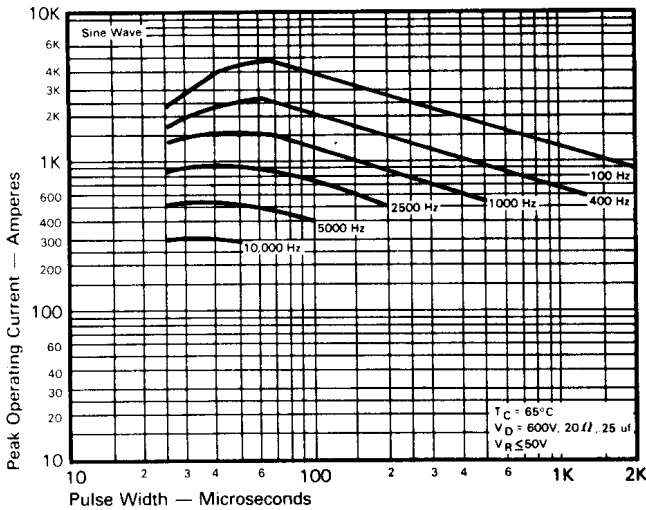

MAXIMUM ALLOWABLE PEAK ON-STATE CURRENT
vs. PULSE WIDTH ($T_C = 65^\circ\text{C}$)

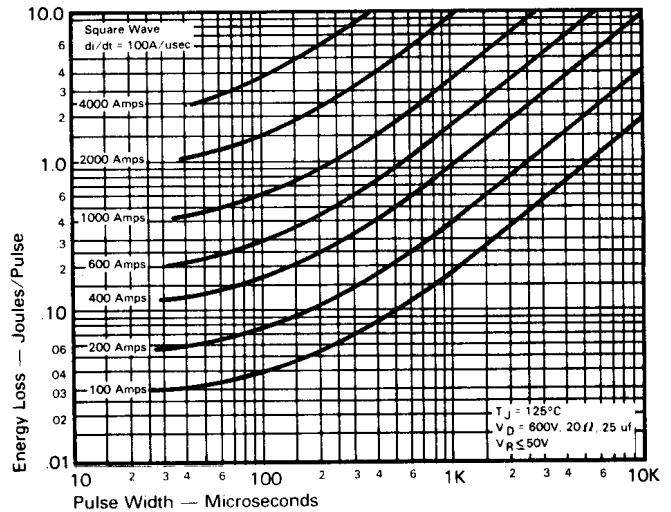

ENERGY PER PULSE FOR TRAPEZOIDAL PULSES
($di/dt = 100\text{A/usec}$)

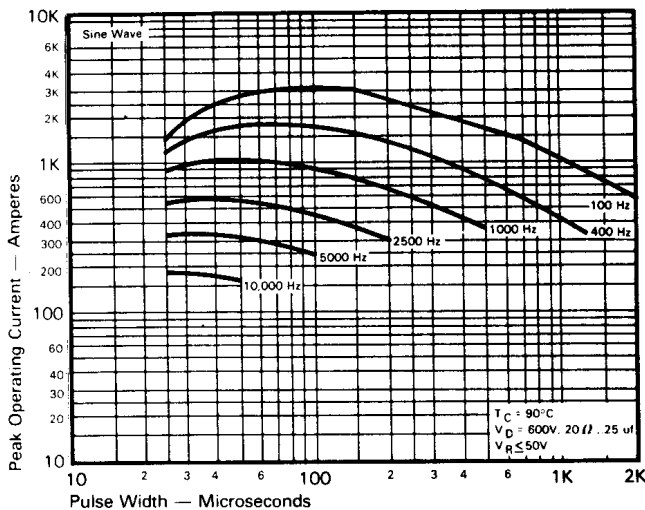

MAXIMUM ALLOWABLE PEAK ON-STATE CURRENT
vs. PULSE WIDTH ($T_C = 90^\circ\text{C}$)

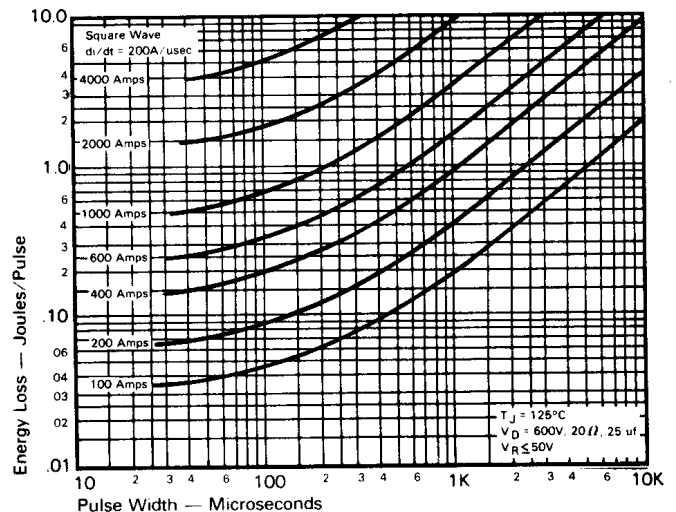

ENERGY PER PULSE FOR TRAPEZOIDAL PULSES
($di/dt = 200\text{A/usec}$)

FAST SWITCHING
THYRISTORS

175A Avg.
(275 RMS)
Up to 1200 Volts
10-50 μ s

Fast Switching
SCR
T607__18

Trapezoidal Wave Current Data
($T_C = 65^\circ\text{C}$)

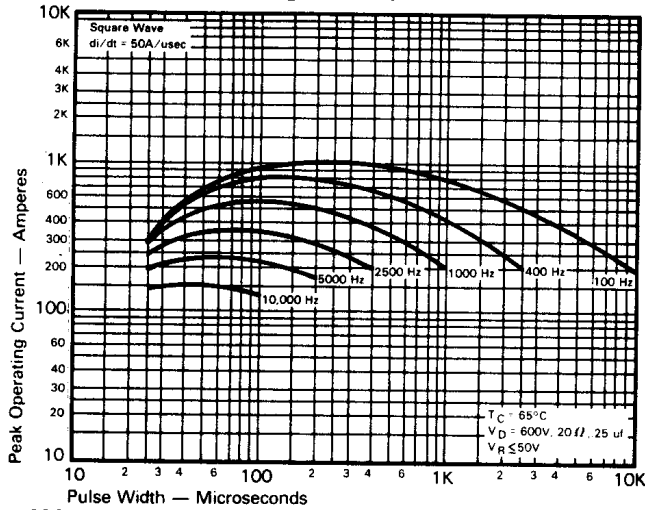

MAXIMUM ALLOWABLE PEAK ON-STATE CURRENT vs. PULSE WIDTH ($di/dt = 50A/us$)

Trapezoidal Wave Current Data
($T_C = 90^\circ\text{C}$)

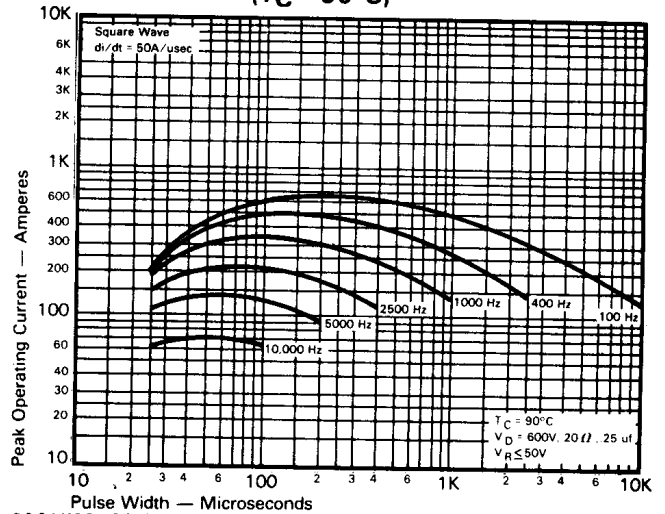

MAXIMUM ALLOWABLE PEAK ON-STATE CURRENT vs. PULSE WIDTH ($di/dt = 50A/us$)

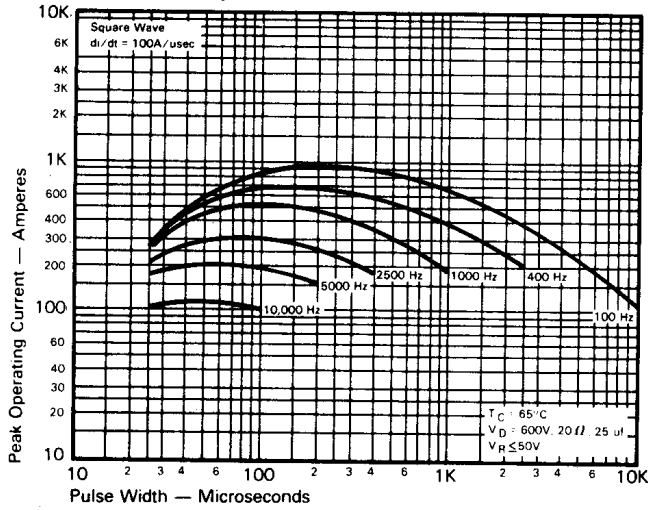

MAXIMUM ALLOWABLE PEAK ON-STATE CURRENT vs. PULSE WIDTH ($di/dt = 100A/us$)

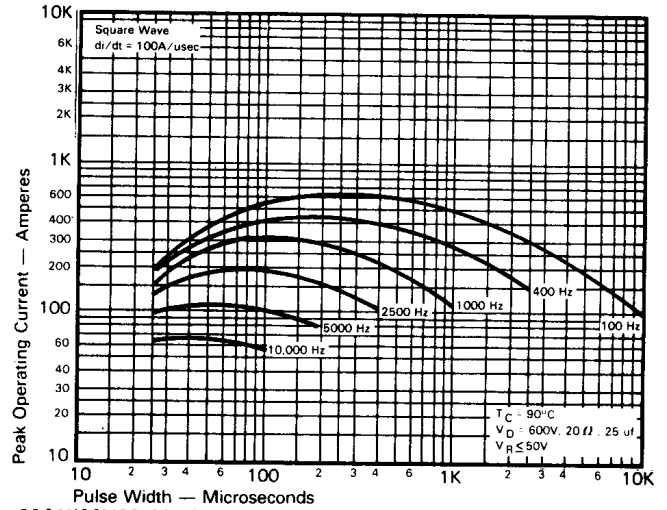

MAXIMUM ALLOWABLE PEAK ON-STATE CURRENT vs. PULSE WIDTH ($di/dt = 100A/us$)

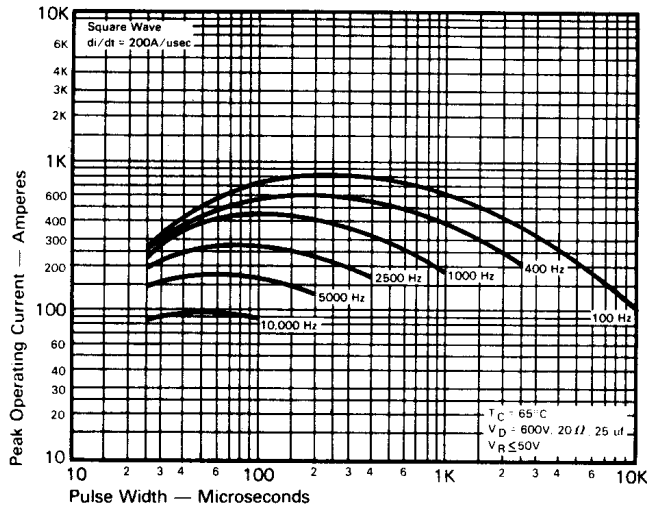

MAXIMUM ALLOWABLE PEAK ON-STATE CURRENT vs. PULSE WIDTH ($di/dt = 200A/us$)

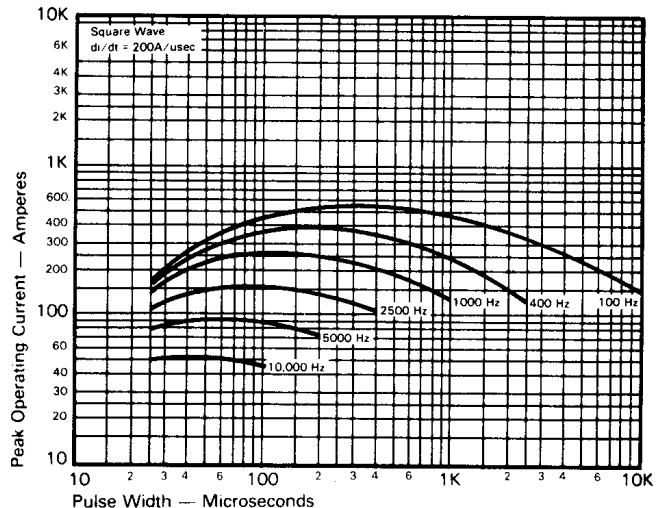

MAXIMUM ALLOWABLE PEAK ON-STATE CURRENT vs. PULSE WIDTH ($di/dt = 200A/us$)

FAST SWITCHING
THYRISTORS

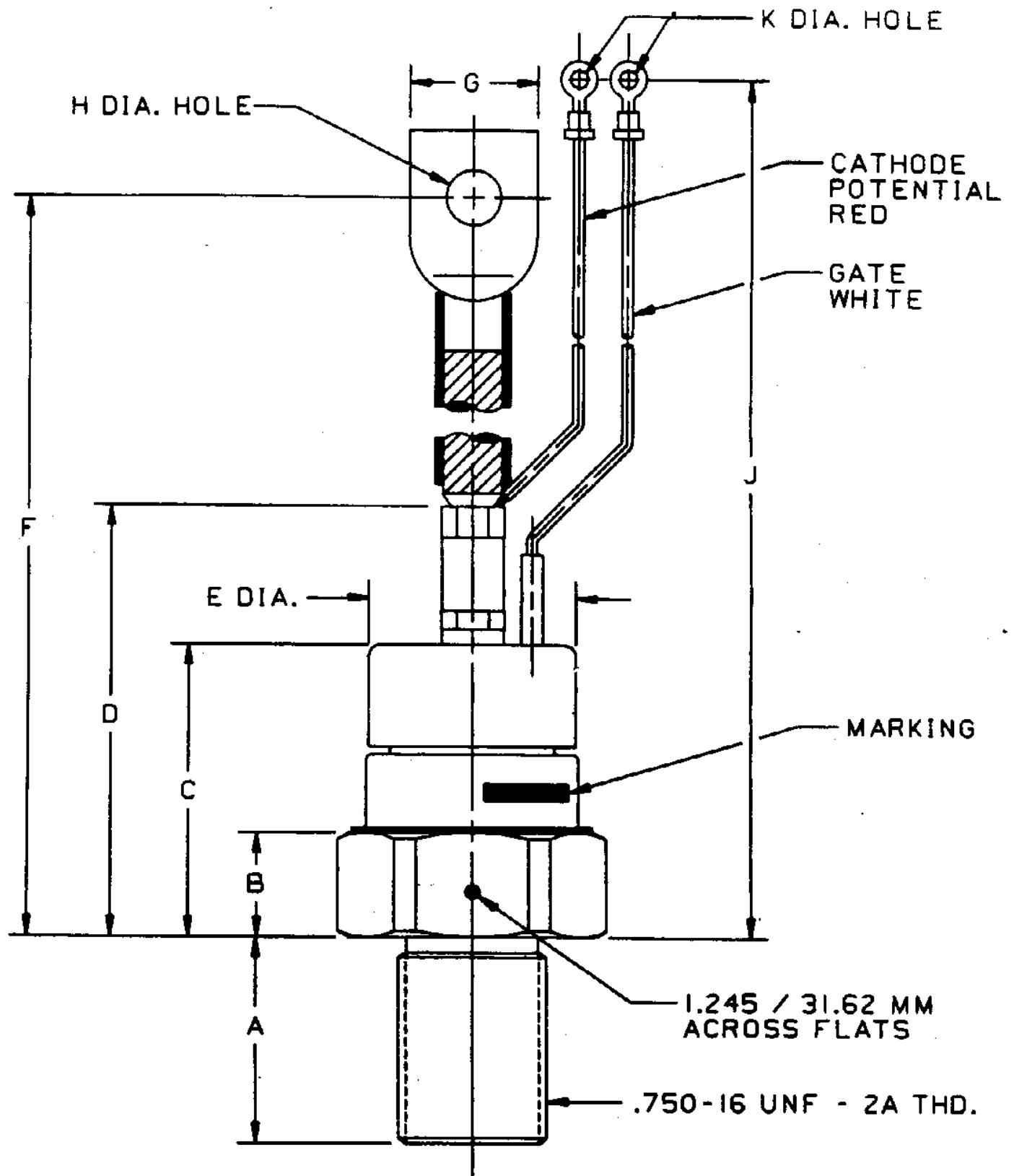

CASE NUMBER T60
NOMINAL DIMENSIONS

STRIKE DISTANCE = .65 INCH / 16.5 MM MIN.
CREEPAGE DISTANCE = .65 INCH / 16.5 MM MIN.

SYM.	A	B	C	D	E	F	G	H	J	K
INCHES	1.06	.55	1.50	2.25	1.07	7.91	.63	.281	7.91	.146
MM	26.9	14.0	38.1	57.2	27.2	200.9	16.0	7.14	200.9	3.71

ALL DIMENSIONS ARE REFERENCE