

Fast Switching SCR T727_45

450A Avg.
(700 RMS)
Up to 1200 Volts
15-60 μ s

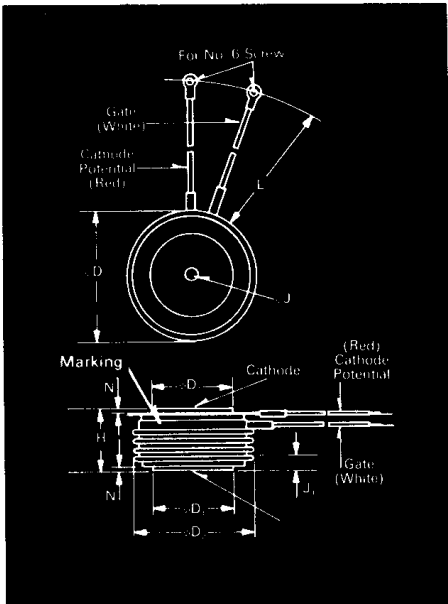

Symbol	Inches		Millimeters	
	Min.	Max.	Min.	Max.
ϕD	2.250	2.290	57.15	58.17
ϕD_1	1.333	1.343	33.86	34.11
ϕD_2	2.030	2.090	51.56	53.09
H	1.020	1.060	25.91	26.92
ϕJ	.135	.145	3.43	3.68
J_1	.075	.090	1.91	2.29
L	7.75	8.50	196.85	215.90
N	.040		1.02	

Creep Distance—1.00 in. min. (25.40 mm).
Strike Distance—.69 in. min. (17.53 mm).
(In accordance with NEMA standards.)
Finish—Nickel Plate.
Approx. Weight—8 oz. (227 g).

1. Dimension "H" is a clamped dimension.

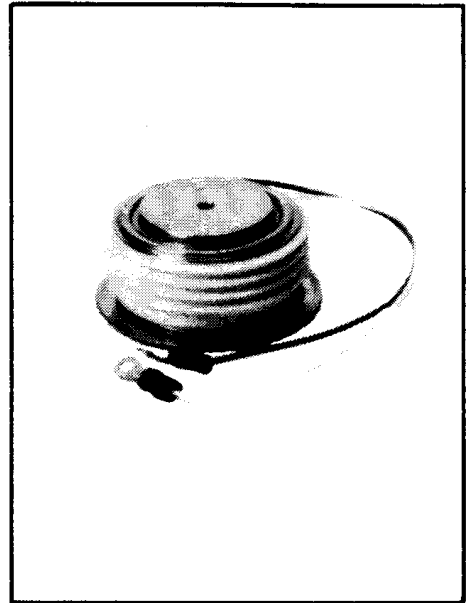

T72 Outline

Features:

- Center fired di/damic gate
- High di/dt with soft gate control
- High frequency operation
- Sinusoidal waveform operation to 20KHz
- Rectangular waveform operation to 20KHz
- Low dynamic forward voltage drop
- Low switching losses at high frequency
- Lifetime Guarantee

Applications:

- Inverters
- UPS
- Induction heating
- AC motor drives
- Cycloconverters
- Choppers
- Crowbars

Ordering Information

Type	Voltage		Current		Turn-off		Gate Current		Leads	
	Code	V_{DRM} and V_{RRM} (V)	Code	$I_T(av)$ (A)	Code	t_q μ sec	Code	I_{GT} (ma)	Case	Code
T727		100	01	450	45	15	7	150	T72	DN
		200	02							
		300	03							
		400	04							
		500	05							
		600	06							
		700	07							
		800	08							
		900	09							
		1000	10							
		1100	11							
		1200	12							
		1400	*14							

Example

Obtain optimum device performance for your application by selecting proper Order Code.

Type T727 rated at 450 A average with $V_{DRM} = 1000V$, $I_{GT} = 150$ ma, $t_q = 30$ μ sec max. and standard control leads—order as:

Type	Voltage	Current	Turn Off	Gate Current	Leads
T 7 2 7	1 0 4	5	5	4	D N

*for 15 and 20 μ sec V_F data, consult factory

450A Avg.
(700 RMS)
Up to 1200 Volts
15-60 μ s

Fast Switching
SCR
T727_45

Voltage

Blocking State Maximums^② ($T_J = 125^\circ\text{C}$)

Repetitive peak forward blocking voltage, V	V_{DRM}
Repetitive peak reverse voltage, V	V_{RRM}
Non-repetitive transient peak reverse voltage, $t \leq 5.0$ msec, V	V_{RSM}
Forward leakage current, mA peak	I_{DRM}
Reverse leakage current, mA peak	I_{RRM}

100	200	300	400	500	600	700	800	900	1000	1100	1200	1400
100	200	300	400	500	600	700	800	900	1000	1100	1200	1400
200	300	400	500	600	700	800	900	1000	1100	1200	1300	1500

← 30 ————— 30 →

Current

Conducting State Maximums
($T_J = 125^\circ\text{C}$)

Symbol	T727---45
RMS forward current, A	$I_{T(rms)}$
Ave. forward current, A	$I_{T(av)}$ 700
One-half cycle surge current ^③ , A	I_{TSM} 450
I^2t for fusing (for times ≥ 8.3 ms) A ² sec.	I^2t 8000 265,000
Forward voltage drop at $I_{TM} = 625$ A and $T_J = 25^\circ\text{C}$, V	V_{TM} 1.45
Min. repetitive di/dt A/ μ sec	di/dt 400

Switching

($T_J = 25^\circ\text{C}$)

Symbol	
Max. turn-off time, $I_T = 400$ A $T_J = 125^\circ\text{C}$, $di/dt = 25$ A/ μ sec, reappplied $dv/dt =$ 20V/ μ sec linear to 0.8 V_{DRM} , μ sec	t_q 15 to 60
Typ. turn-on-time, $I_T = 1000$ A $V_D = 300$ V, μ sec	t_{on} 3.0
Min. critical dv/dt , exponential to V_{DRM} $T_J = 125^\circ\text{C}$, V/ μ sec	dv/dt 300
Min. di/dt non-repetitive, A/ μ sec	di/dt 800

Gate

Maximum Parameters
($T_J = 25^\circ\text{C}$)

Symbol	
Gate current to trigger at $V_D = 12$ V, mA	I_{GT} 150
Gate voltage to trigger at $V_D = 12$ V, V	V_{GT} 3
Non-triggering gate voltage, $T_J = 125^\circ\text{C}$, and rated V_{DRM} , V	V_{GDM} 0.15
Peak forward gate current, A	I_{GTM} 4
Peak reverse gate voltage, V	V_{GRM} 5
Peak gate power, Watts	P_{GM} 16
Average gate power, Watts	$P_{G(av)}$ 3

Thermal and Mechanical

Symbol	
Min., Max. oper. junction temp., $^\circ\text{C}$	T_J -40 to +125
Min., Max. storage temp., $^\circ\text{C}$	T_{stg} -40 to +150
Max. mounting torque, in lb.	2000 to 2400
Max. Thermal resistance ^① Double side cooled Junction to case, $^\circ\text{C}/\text{Watt}$	$R_{\theta JC}$.06
Case to sink, lubricated, $^\circ\text{C}/\text{Watt}$	$R_{\theta CS}$.02

- ① Consult recommended mounting procedures.
- ② Applies for zero or negative gate bias.
- ③ Per JEDEC RS-397, 5.2.2.1.
- ④ With recommended gate drive.
- ⑤ Higher dv/dt ratings available, consult factory.
- ⑥ Per JEDEC standard RS-397, 5.2.2.6.
- ⑦ For operation with antiparallel diode, consult factory.

Maximum Forward Voltage Drop VS Forward Current

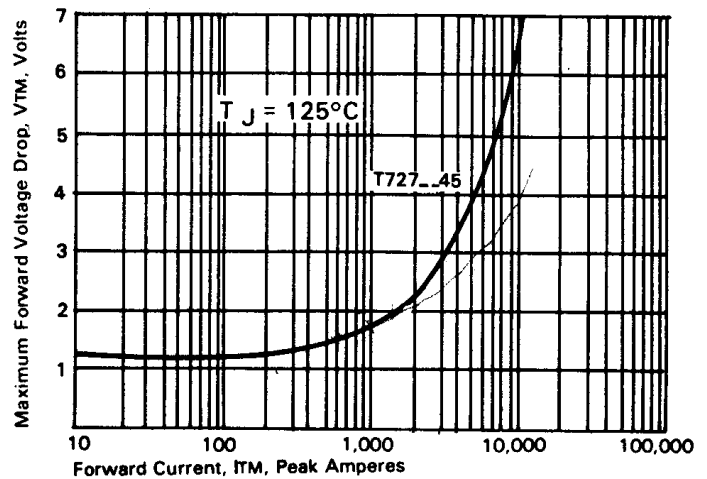

Transient Thermal Impedance VS. Time

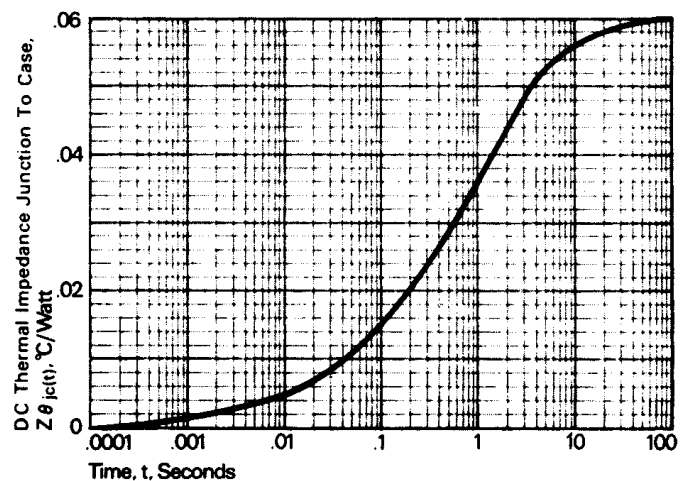

FAST SWITCHING THYRISTORS

Fast Switching SCR T727_45

450A Avg.
(700 RMS)
Up to 1200 Volts
15-60 μ s

Sinusoidal Current Data

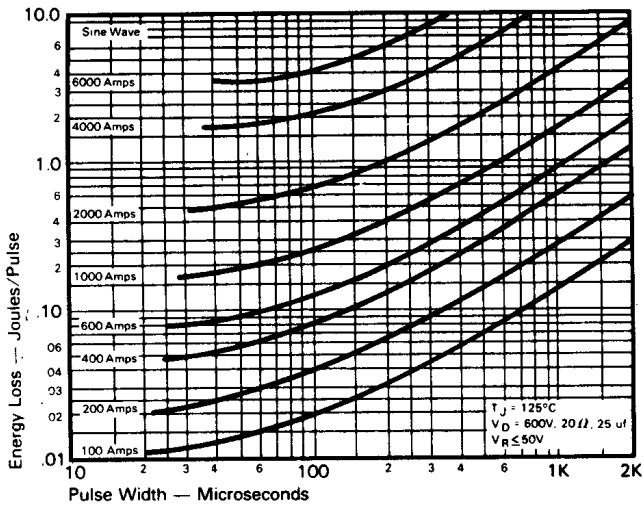

ENERGY PER PULSE FOR SINUSOIDAL PULSES

Trapezoidal Wave Current Data

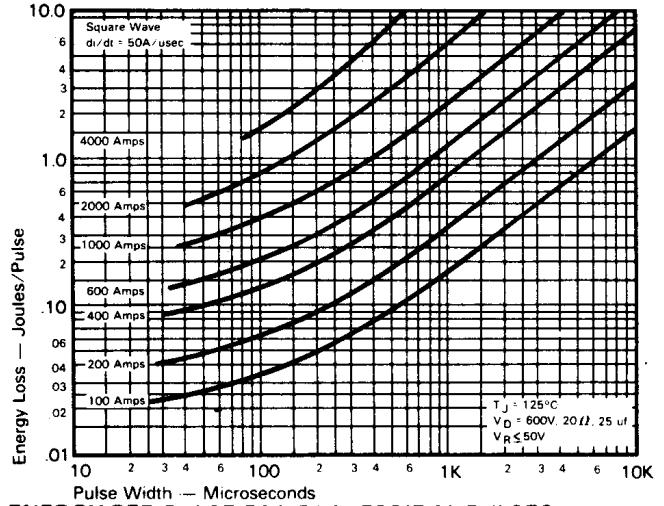

ENERGY PER PULSE FOR TRAPEZOIDAL PULSES
($di/dt = 50\text{A/usec}$)

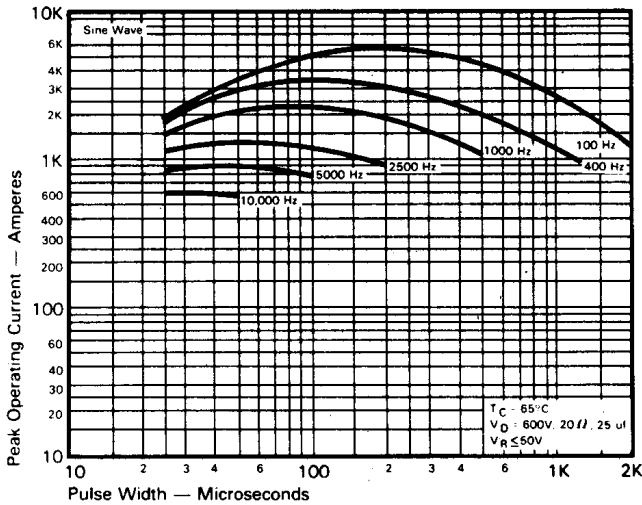

MAXIMUM ALLOWABLE PEAK ON-STATE CURRENT
vs. PULSE WIDTH ($T_C = 65^\circ\text{C}$)

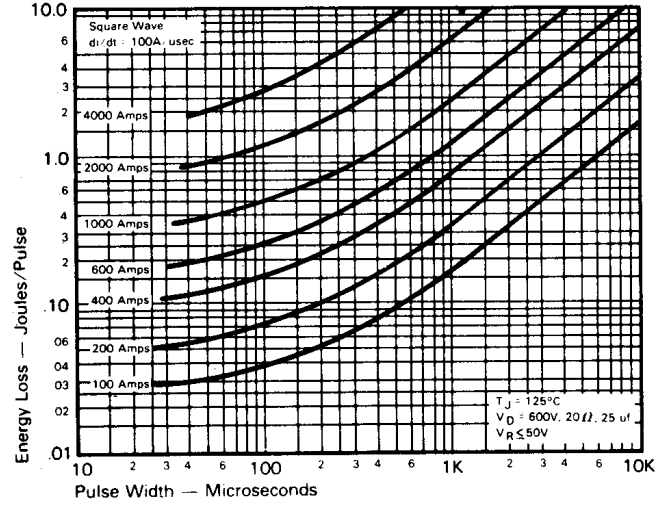

ENERGY PER PULSE FOR TRAPEZOIDAL PULSES
($di/dt = 100\text{A/usec}$)

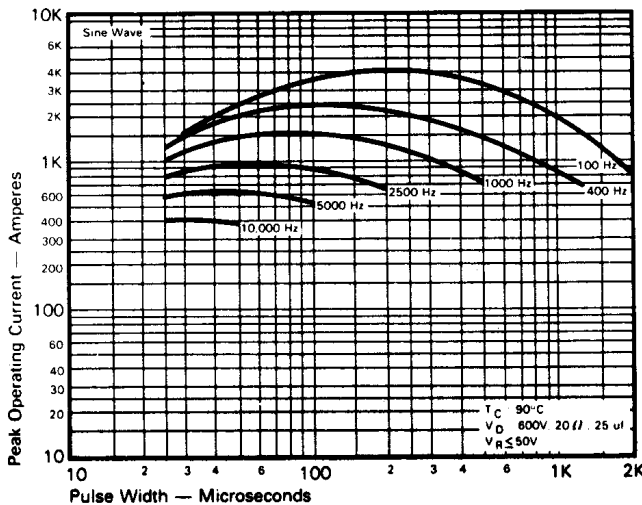

MAXIMUM ALLOWABLE PEAK ON-STATE CURRENT
vs. PULSE WIDTH ($T_C = 90^\circ\text{C}$)

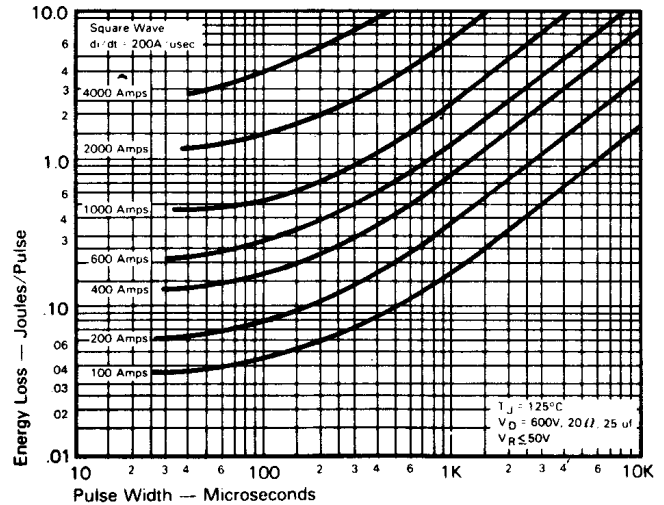

ENERGY PER PULSE FOR TRAPEZOIDAL PULSES
($di/dt = 200\text{A/usec}$)

FAST SWITCHING
THYRISTORS

**450A Avg.
(700 RMS)
Up to 1200 Volts
15-60 μ s**

**Fast Switching
SCR
T727_45**

**Trapezoidal Wave Current Data
($T_C = 65^\circ\text{C}$)**

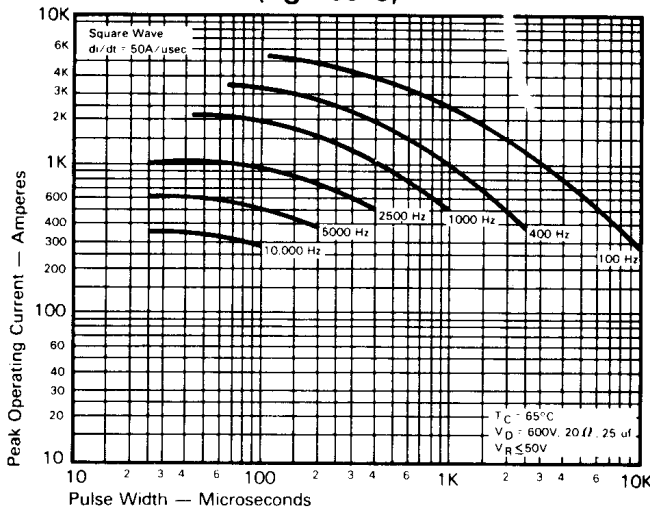

MAXIMUM ALLOWABLE PEAK ON-STATE CURRENT vs. PULSE WIDTH ($di/dt = 50A/usec$)

**Trapezoidal Wave Current Data
($T_C = 90^\circ\text{C}$)**

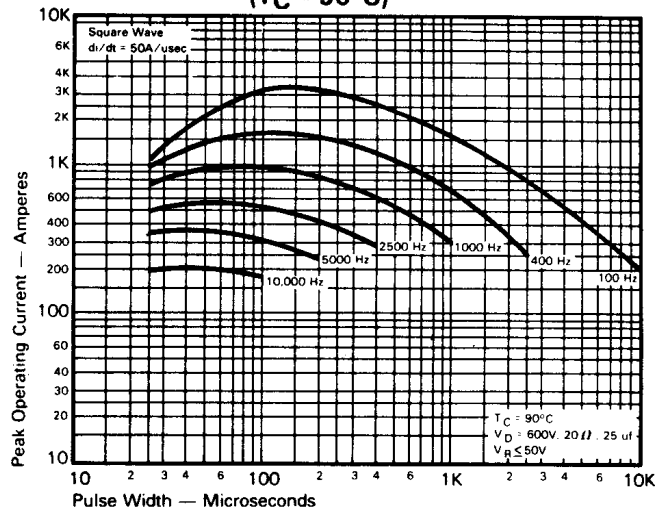

MAXIMUM ALLOWABLE PEAK ON-STATE CURRENT vs. PULSE WIDTH ($di/dt = 50A/usec$)

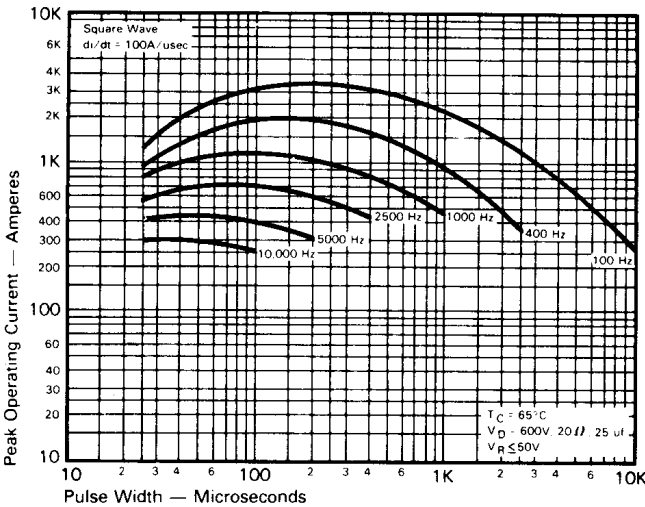

MAXIMUM ALLOWABLE PEAK ON-STATE CURRENT vs. PULSE WIDTH ($di/dt = 100A/usec$)

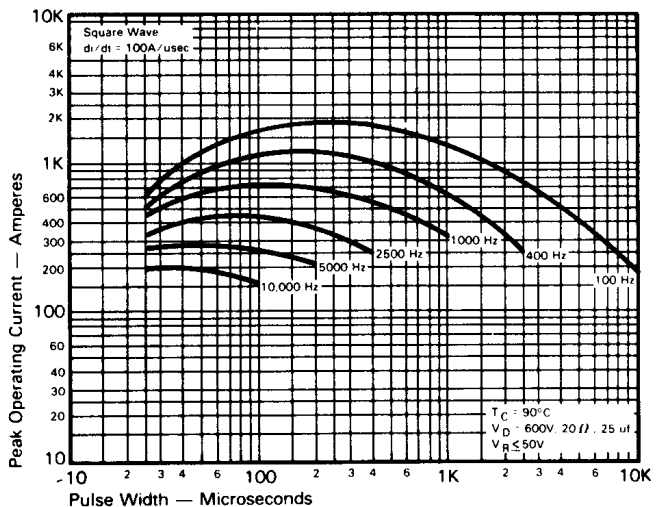

MAXIMUM ALLOWABLE PEAK ON-STATE CURRENT vs. PULSE WIDTH ($di/dt = 100A/usec$)

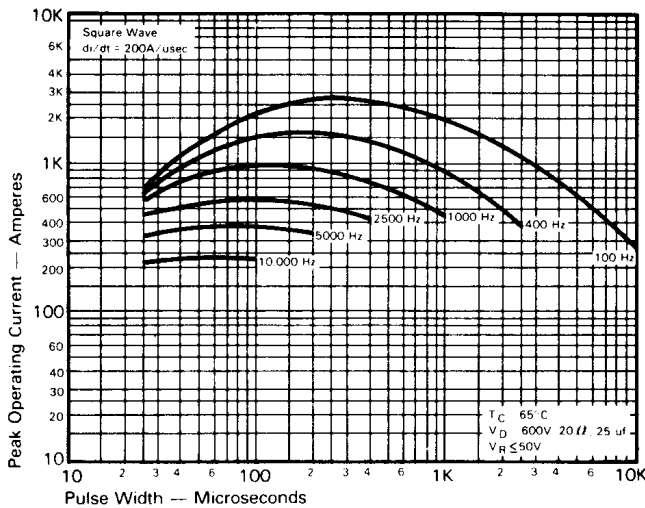

MAXIMUM ALLOWABLE PEAK ON-STATE CURRENT vs. PULSE WIDTH ($di/dt = 200A/usec$)

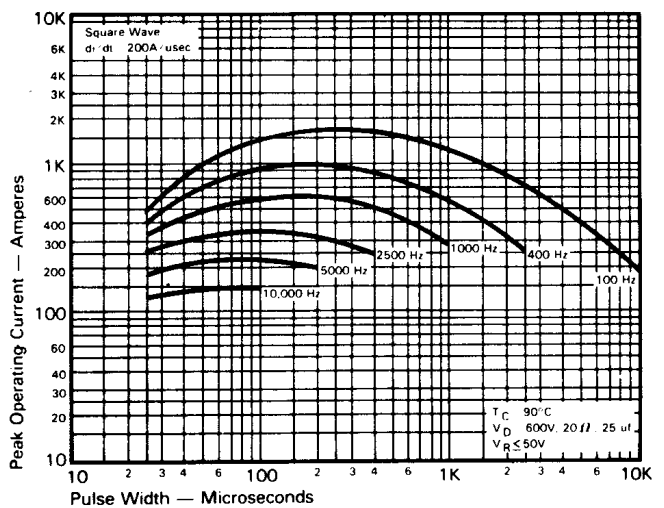

MAXIMUM ALLOWABLE PEAK ON-STATE CURRENT vs. PULSE WIDTH ($di/dt = 200A/usec$)

FAST SWITCHING THYRISTORS

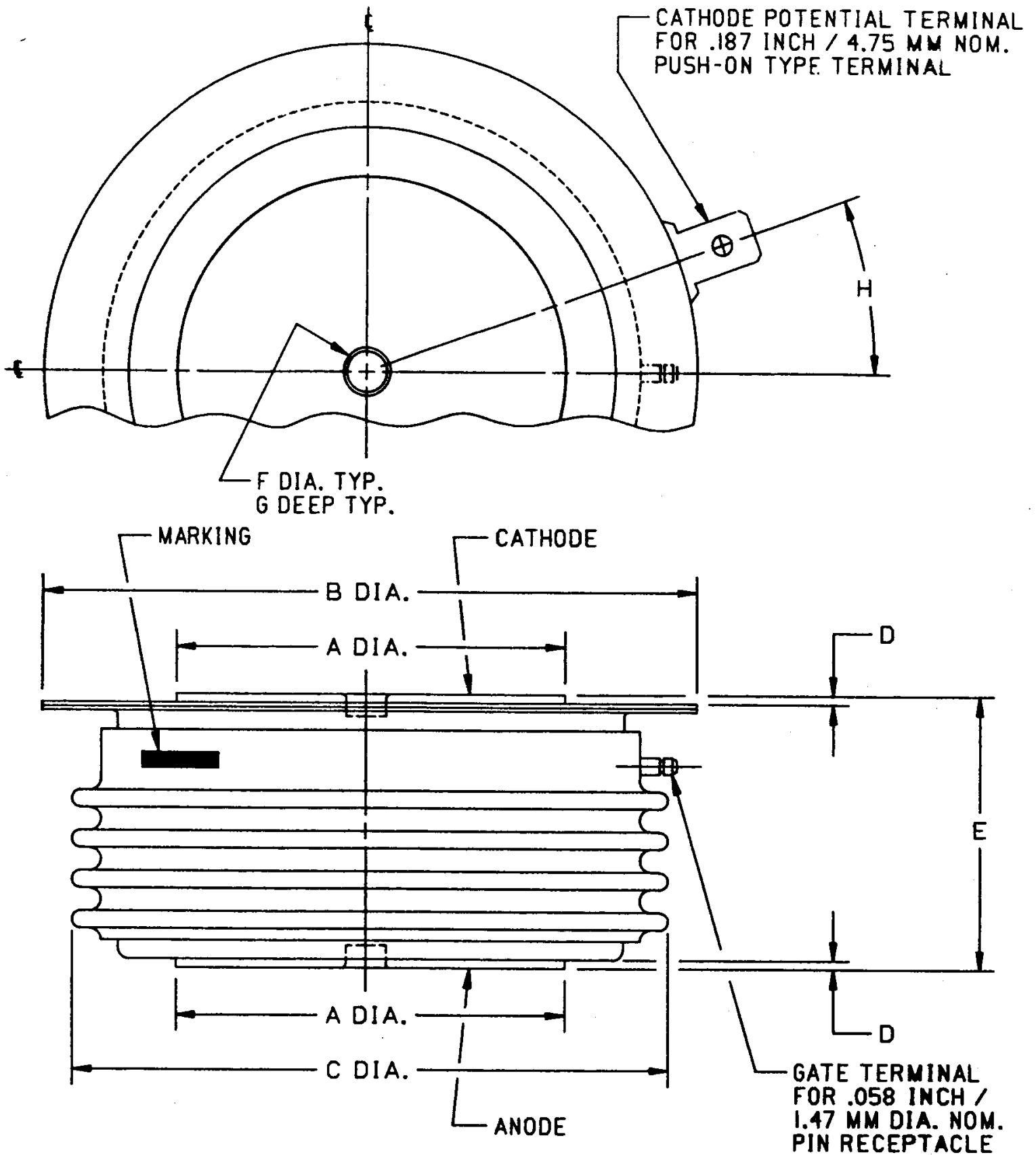

CASE NUMBER T72
 NOMINAL DIMENSIONS

STRIKE DISTANCE = .58 INCH / 14.7 MM MIN.
 CREEPAGE DISTANCE = 1.00 INCH / 25.4 MM MIN.

SYM.	A	B	C	D	E	F	G	H
INCHES	1.34	2.28	2.05	.030	1.020/1.060	.140	.080	20°
MM	34.0	57.9	52.1	0.76	25.91/26.92	3.56	2.03	20°

ALL DIMENSIONS ARE REFERENCE