

Prepared by	S. Iura	Revision: 1.6
Approved by	H. Yamaguchi : Apr. 2011	

MITSUBISHI HVIGBT MODULES

CM1500HC-66R

HIGH POWER SWITCHING USE
INSULATED TYPE

4th-Version HVIGBT (High Voltage Insulated Gate Bipolar Transistor) Modules

CM1500HC-66R



- I_C 1500 A
- V_{CES} 3300 V
- 1-element in a Pack
- Insulated Type
- LPT-IGBT / Soft Recovery Diode
- AISiC Baseplate

APPLICATION

Traction drives, High Reliability Converters / Inverters, DC choppers

OUTLINE DRAWING & CIRCUIT DIAGRAM

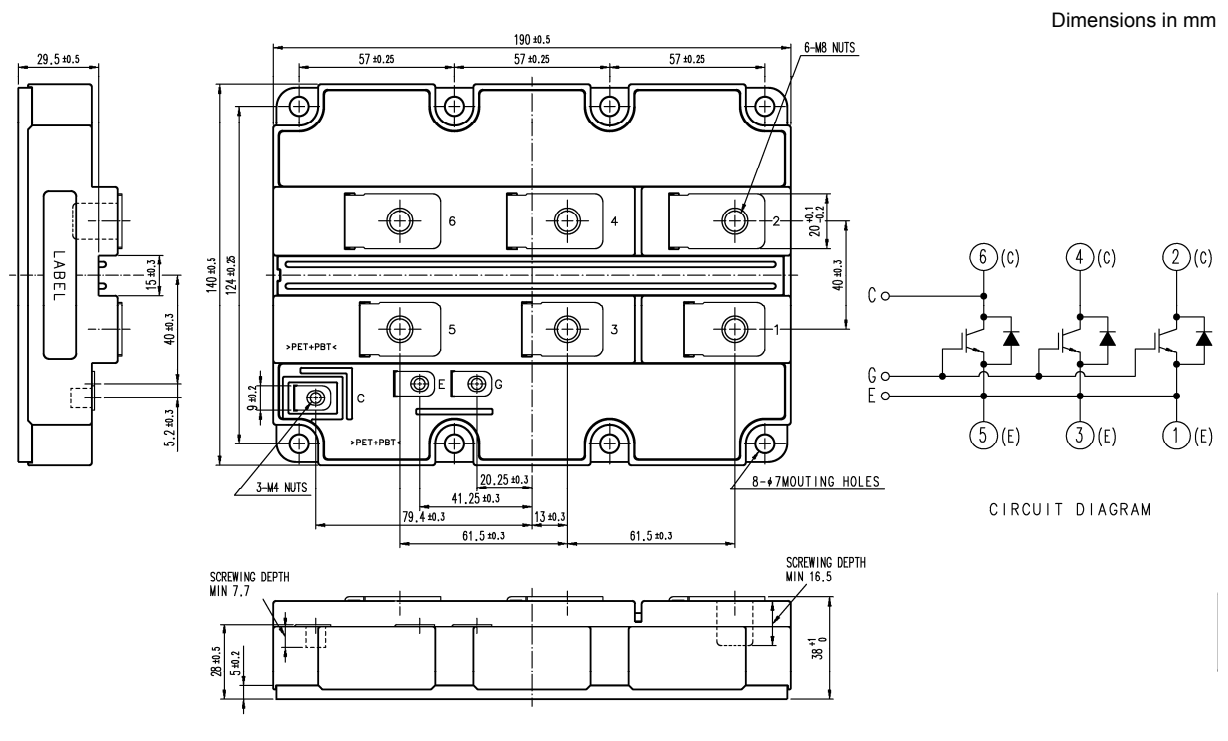

HVIGBT (High Voltage Insulated Gate Bipolar Transistor) MODULES



CM1500HC-66R

HIGH POWER SWITCHING USE
INSULATED TYPE

4th-Version HVIGBT (High Voltage Insulated Gate Bipolar Transistor) Modules

MAXIMUM RATINGS

Symbol	Item	Conditions	Ratings	Unit
V _{CES}	Collector-emitter voltage	V _{GE} = 0V, T _j = -40...+150°C	3300	V
		V _{GE} = 0V, T _j = -50°C	3200	
V _{GES}	Gate-emitter voltage	V _{CE} = 0V, T _j = 25°C	± 20	V
I _C	Collector current	DC, T _c = 95°C	1500	A
I _{CM}		Pulse ^(Note 1)	3000	A
I _E	Emitter current ^(Note 2)	DC	1500	A
I _{EM}		Pulse ^(Note 1)	3000	A
P _c	Maximum power dissipation ^(Note 3)	T _c = 25°C, IGBT part	15600	W
V _{iso}	Isolation voltage	RMS, sinusoidal, f = 60Hz, t = 1 min.	6000	V
V _e	Partial discharge extinction voltage	RMS, sinusoidal, f = 60Hz, Q _{PD} ≤ 10 pC	2600	V
T _j	Junction temperature		-50 ~ +150	°C
T _{op}	Operating temperature		-50 ~ +150	°C
T _{stg}	Storage temperature		-55 ~ +150	°C
t _{psc}	Maximum short circuit pulse width	V _{CC} = 2500V, V _{CE} ≤ V _{CES} , V _{GE} = 15V, T _j = 150°C	10	μs

ELECTRICAL CHARACTERISTICS

Symbol	Item	Conditions	Limits			Unit	
			Min	Typ	Max		
I _{CES}	Collector cutoff current	V _{CE} = V _{CES} , V _{GE} = 0V	T _j = 25°C	—	—	6.0	mA
			T _j = 125°C	—	6.0	—	
			T _j = 150°C	—	36.0	—	
V _{GE(th)}	Gate-emitter threshold voltage	V _{CE} = 10 V, I _C = 150 mA, T _j = 25°C	5.7	6.2	6.7	V	
I _{GES}	Gate leakage current	V _{GE} = V _{GES} , V _{CE} = 0V, T _j = 25°C	-0.5	—	0.5	μA	
C _{ies}	Input capacitance	V _{CE} = 10 V, V _{GE} = 0 V, f = 100 kHz T _j = 25°C	—	210.0	—	nF	
C _{oes}	Output capacitance		—	13.0	—	nF	
C _{res}	Reverse transfer capacitance		—	6.0	—	nF	
Q _g	Total gate charge	V _{CC} = 1800 V, I _C = 1500 A, V _{GE} = ±15 V	—	16.0	—	μC	
V _{CE(sat)}	Collector-emitter saturation voltage	I _C = 1500 A ^(Note 4) V _{GE} = 15 V	T _j = 25°C	—	2.45	—	V
			T _j = 125°C	—	3.10	3.70	
			T _j = 150°C	—	3.25	—	
t _{d(on)}	Turn-on delay time	V _{CC} = 1800 V I _C = 1500 A V _{GE} = ±15 V	T _j = 25°C	—	1.00	—	μs
			T _j = 125°C	—	0.95	1.25	
			T _j = 150°C	—	0.95	1.25	
t _r	Turn-on rise time	V _{CC} = 1800 V I _C = 1500 A V _{GE} = ±15 V	T _j = 25°C	—	0.28	—	μs
			T _j = 125°C	—	0.30	0.50	
			T _j = 150°C	—	0.30	0.50	
E _{on(10%)}	Turn-on switching energy ^(Note 5)	R _{G(on)} = 1.6 Ω L _s = 100 nH Inductive load	T _j = 25°C	—	2.10	—	J/P
			T _j = 125°C	—	2.75	—	
			T _j = 150°C	—	3.00	—	
E _{on}	Turn-on switching energy ^(Note 6)	V _{CC} = 1800 V I _C = 1500 A V _{GE} = ±15 V	T _j = 25°C	—	2.20	—	J/P
			T _j = 125°C	—	2.90	—	
			T _j = 150°C	—	3.20	—	

HVIGBT (High Voltage Insulated Gate Bipolar Transistor) MODULES



CM1500HC-66R

HIGH POWER SWITCHING USE
INSULATED TYPE

4th-Version HVIGBT (High Voltage Insulated Gate Bipolar Transistor) Modules

Symbol	Item	Conditions	Limits			Unit	
			Min	Typ	Max		
$t_{d(off)}$	Turn-off delay time	$V_{CC} = 1800\text{ V}$ $I_C = 1500\text{ A}$ $V_{GE} = \pm 15\text{ V}$ $R_{G(off)} = 5.6\ \Omega$ $L_s = 100\text{ nH}$ Inductive load	$T_J = 25^\circ\text{C}$	—	2.70	—	μs
			$T_J = 125^\circ\text{C}$	—	2.80	3.30	
			$T_J = 150^\circ\text{C}$	—	2.85	3.30	
t_f	Turn-off fall time		$T_J = 25^\circ\text{C}$	—	0.30	—	μs
			$T_J = 125^\circ\text{C}$	—	0.35	1.00	
			$T_J = 150^\circ\text{C}$	—	0.40	1.00	
$E_{off(10\%)}$	Turn-off switching energy (Note 5)		$T_J = 25^\circ\text{C}$	—	2.00	—	J/P
			$T_J = 125^\circ\text{C}$	—	2.45	—	
			$T_J = 150^\circ\text{C}$	—	2.50	—	
E_{off}	Turn-off switching energy (Note 6)	$T_J = 25^\circ\text{C}$	—	2.20	—	J/P	
		$T_J = 125^\circ\text{C}$	—	2.70	—		
		$T_J = 150^\circ\text{C}$	—	2.80	—		
V_{EC}	Emitter-collector voltage (Note 2)	$I_E = 1500\text{ A}$ (Note 4) $V_{GE} = 0\text{ V}$	$T_J = 25^\circ\text{C}$	—	2.15	—	V
			$T_J = 125^\circ\text{C}$	—	2.30	2.80	
			$T_J = 150^\circ\text{C}$	—	2.25	—	
t_{rr}	Reverse recovery time (Note 2)		$T_J = 25^\circ\text{C}$	—	0.50	—	μs
			$T_J = 125^\circ\text{C}$	—	0.70	—	
			$T_J = 150^\circ\text{C}$	—	0.80	—	
I_{rr}	Reverse recovery current (Note 2)		$T_J = 25^\circ\text{C}$	—	1250	—	A
			$T_J = 125^\circ\text{C}$	—	1500	—	
			$T_J = 150^\circ\text{C}$	—	1550	—	
Q_{rr}	Reverse recovery charge (Note 2)	$T_J = 25^\circ\text{C}$	—	1050	—	μC	
		$T_J = 125^\circ\text{C}$	—	1700	—		
		$T_J = 150^\circ\text{C}$	—	2000	—		
$E_{rec(10\%)}$	Reverse recovery energy (Note 2) (Note 5)	$T_J = 25^\circ\text{C}$	—	1.05	—	J/P	
		$T_J = 125^\circ\text{C}$	—	1.75	—		
		$T_J = 150^\circ\text{C}$	—	2.00	—		
E_{rec}	Reverse recovery energy (Note 2) (Note 6)	$T_J = 25^\circ\text{C}$	—	1.20	—	J/P	
		$T_J = 125^\circ\text{C}$	—	2.00	—		
		$T_J = 150^\circ\text{C}$	—	2.30	—		

CM1500HC-66R

HIGH POWER SWITCHING USE
INSULATED TYPE

4th-Version HVIGBT (High Voltage Insulated Gate Bipolar Transistor) Modules

THERMAL CHARACTERISTICS

Symbol	Item	Conditions	Limits			Unit
			Min	Typ	Max	
$R_{th(j-c)Q}$	Thermal resistance	Junction to Case, IGBT part	—	—	8.0	K/kW
$R_{th(j-c)R}$	Thermal resistance	Junction to Case, FWDi part	—	—	15.0	K/kW
$R_{th(c-f)}$	Contact thermal resistance	Case to Fin, $\lambda_{grease} = 1W/m \cdot K$, $D_{(c-f)} = 100 \mu m$	—	6.0	—	K/kW

MECHANICAL CHARACTERISTICS

Symbol	Item	Conditions	Limits			Unit
			Min	Typ	Max	
M_t	Mounting torque	M8: Main terminals screw	7.0	—	22.0	N·m
M_s		M6: Mounting screw	3.0	—	6.0	N·m
M_t		M4: Auxiliary terminals screw	1.0	—	3.0	N·m
m	Mass		—	1.2	—	kg
CTI	Comparative tracking index		600	—	—	—
d_a	Clearance		19.5	—	—	mm
d_s	Creepage distance		32.0	—	—	mm
$L_{P_{CE}}$	Parasitic stray inductance		—	11.0	—	nH
R_{CC+EE}	Internal lead resistance	$T_c = 25^\circ C$	—	0.12	—	m Ω
r_g	Internal gate resistor	$T_c = 25^\circ C$	—	1.5	—	Ω

- Note 1. Pulse width and repetition rate should be such that junction temperature (T_j) does not exceed T_{opmax} rating (150°C).
 Note 2. The symbols represent characteristics of the anti-parallel, emitter to collector free-wheel diode (FWDi).
 Note 3. Junction temperature (T_j) should not exceed T_{jmax} rating (150°C).
 Note 4. Pulse width and repetition rate should be such as to cause negligible temperature rise.
 Note 5. $E_{on(10\%)} / E_{off(10\%)} / E_{rec(10\%)}$ are the integral of $0.1V_{CE} \times 0.1I_C \times dt$.
 Note 6. The integration range of $E_{on} / E_{off} / E_{rec}$ according to IEC 60747.

CM1500HC-66R

HIGH POWER SWITCHING USE
INSULATED TYPE

4th-Version HVIGBT (High Voltage Insulated Gate Bipolar Transistor) Modules

PERFORMANCE CURVES

OUTPUT CHARACTERISTICS (TYPICAL)

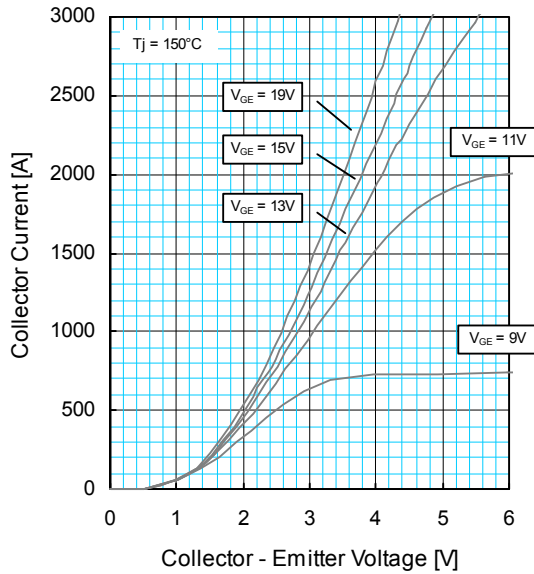

TRANSFER CHARACTERISTICS (TYPICAL)

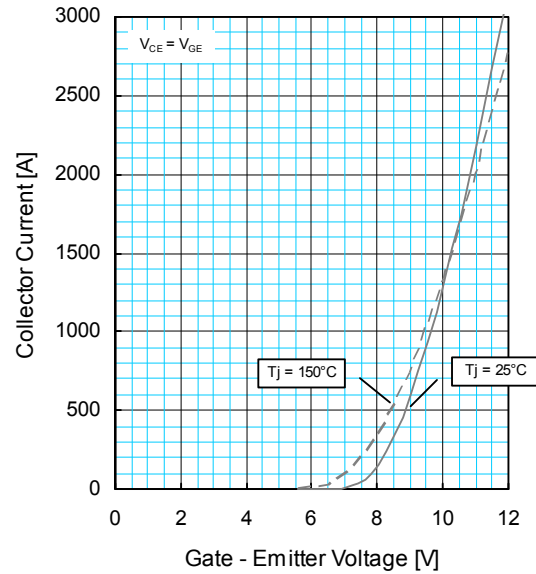

COLLECTOR-EMITTER SATURATION VOLTAGE CHARACTERISTICS (TYPICAL)

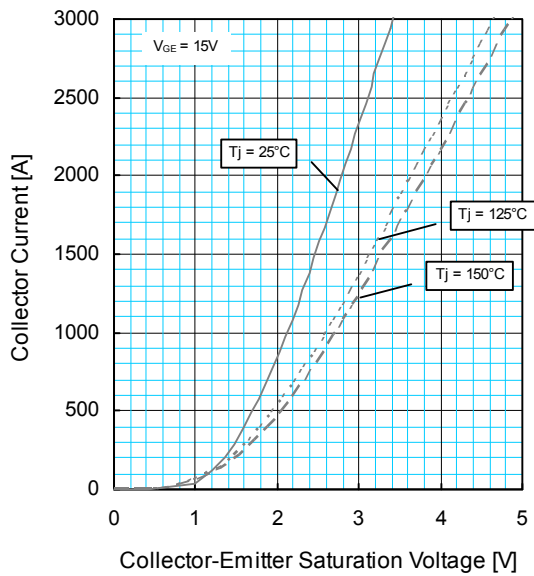

FREE-WHEEL DIODE FORWARD CHARACTERISTICS (TYPICAL)

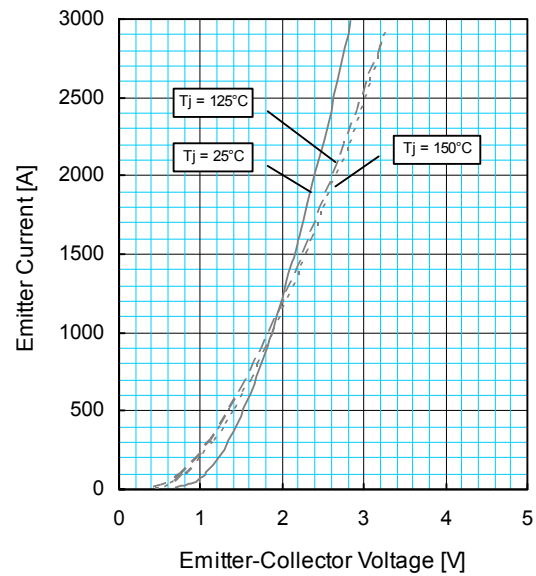

CM1500HC-66R

HIGH POWER SWITCHING USE
INSULATED TYPE

4th-Version HVIGBT (High Voltage Insulated Gate Bipolar Transistor) Modules

PERFORMANCE CURVES

CAPACITANCE CHARACTERISTICS (TYPICAL)

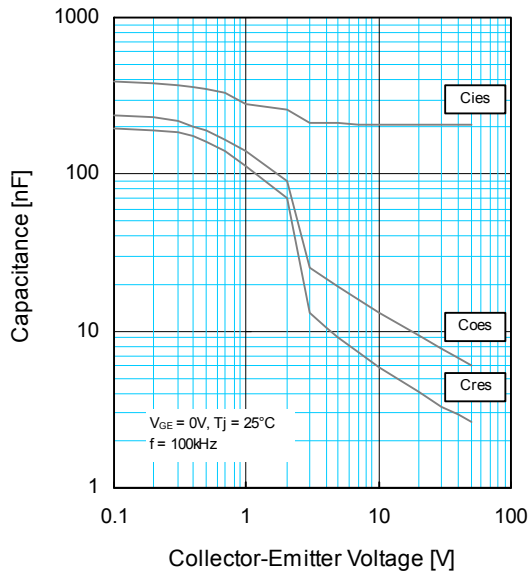

GATE CHARGE CHARACTERISTICS (TYPICAL)

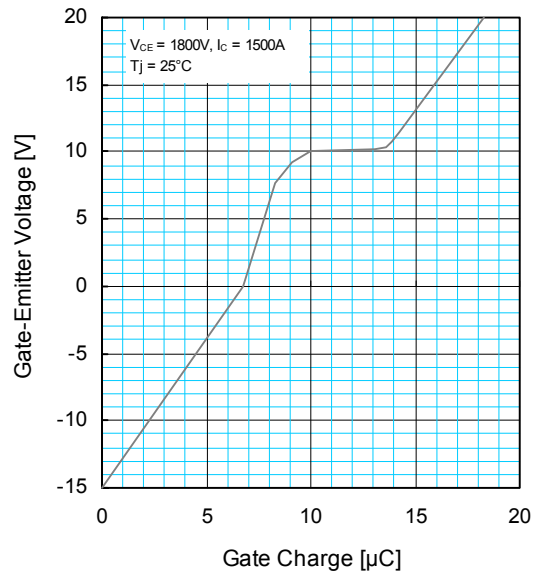

HALF-BRIDGE SWITCHING ENERGY CHARACTERISTICS (TYPICAL)

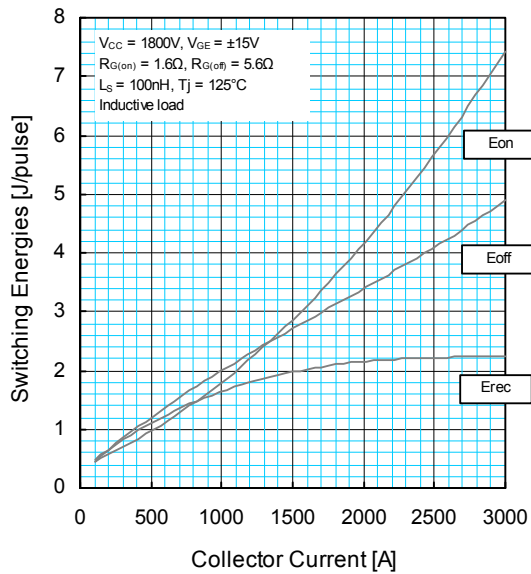

HALF-BRIDGE SWITCHING ENERGY CHARACTERISTICS (TYPICAL)

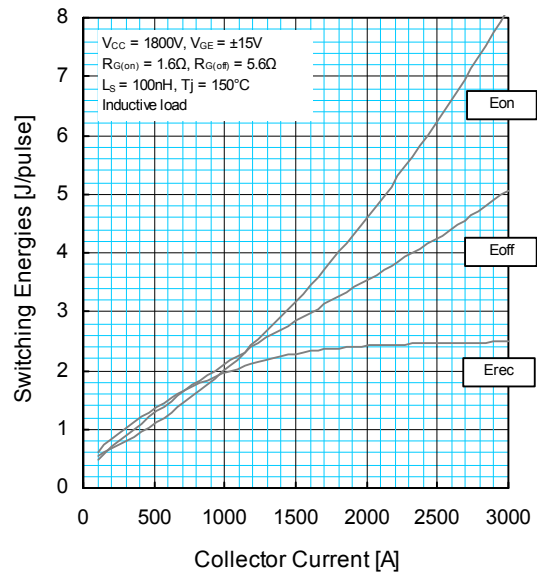

HVIGBT (High Voltage Insulated Gate Bipolar Transistor) MODULES



CM1500HC-66R

HIGH POWER SWITCHING USE
INSULATED TYPE

4th-Version HVIGBT (High Voltage Insulated Gate Bipolar Transistor) Modules

PERFORMANCE CURVES

HALF-BRIDGE SWITCHING ENERGY CHARACTERISTICS (TYPICAL)

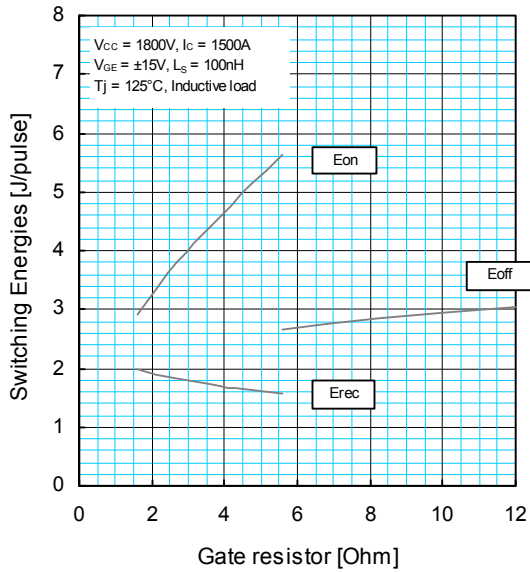

HALF-BRIDGE SWITCHING ENERGY CHARACTERISTICS (TYPICAL)

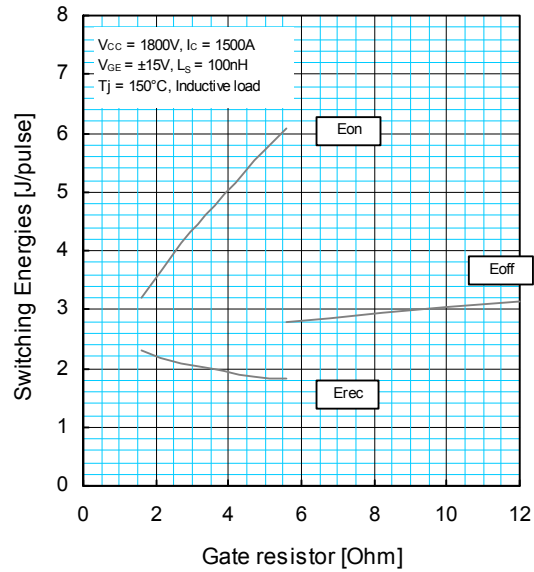

HALF-BRIDGE SWITCHING TIME CHARACTERISTICS (TYPICAL)

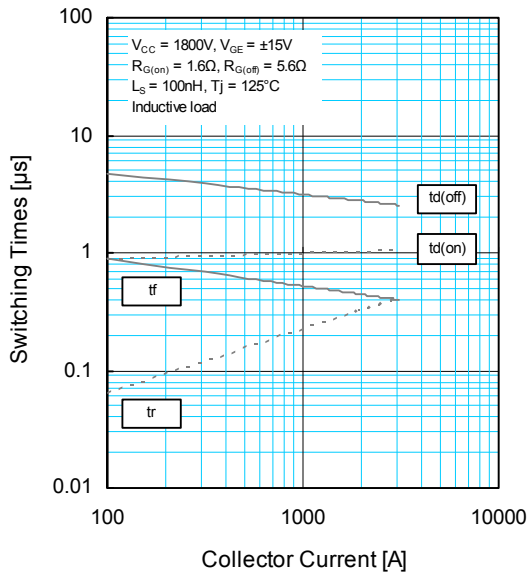

HALF-BRIDGE SWITCHING TIME CHARACTERISTICS (TYPICAL)

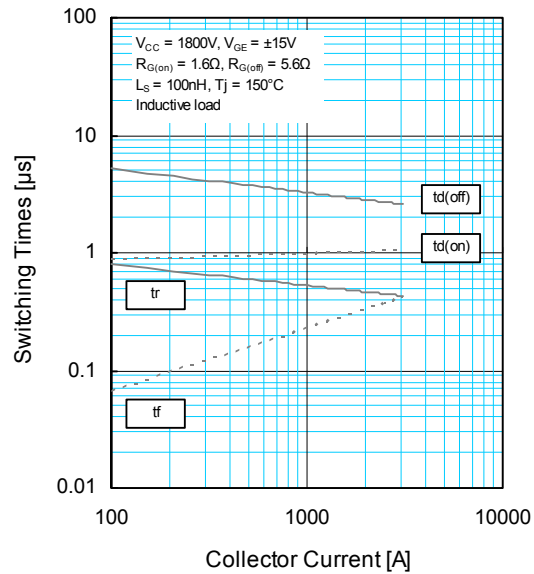

HVIGBT (High Voltage Insulated Gate Bipolar Transistor) MODULES



CM1500HC-66R

HIGH POWER SWITCHING USE
INSULATED TYPE

4th-Version HVIGBT (High Voltage Insulated Gate Bipolar Transistor) Modules

PERFORMANCE CURVES

FREE-WHEEL DIODE REVERSE RECOVERY CHARACTERISTICS (TYPICAL)

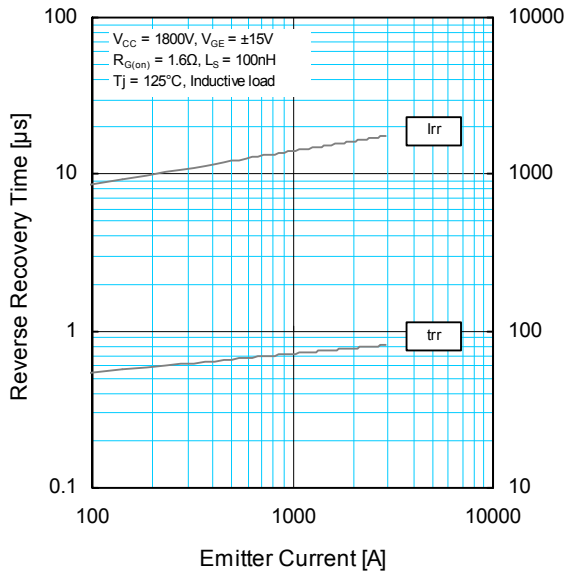

FREE-WHEEL DIODE REVERSE RECOVERY CHARACTERISTICS (TYPICAL)

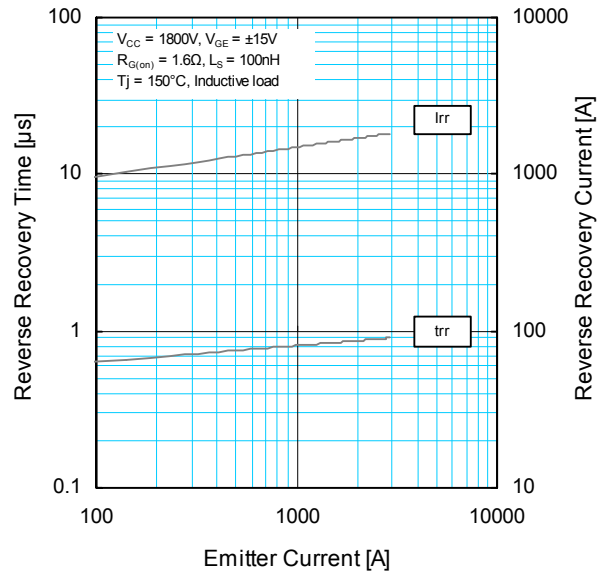

TRANSIENT THERMAL IMPEDANCE CHARACTERISTICS

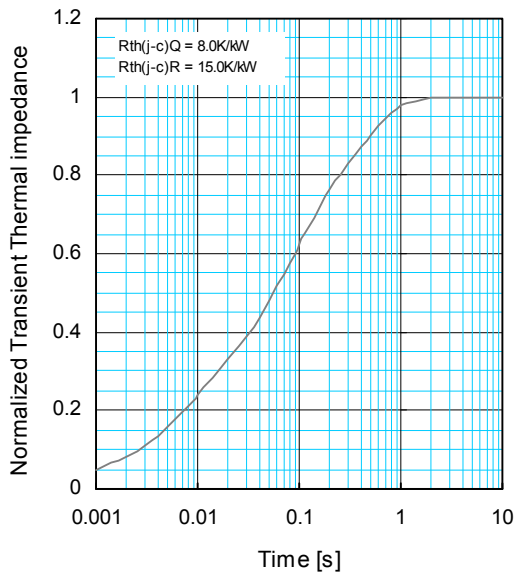

$$Z_{th(j-c)}(t) = \sum_{i=1}^n R_i \left\{ 1 - \exp\left(-\frac{t}{\tau_i}\right) \right\}$$

	1	2	3	4
R _i [K/kW] :	0.0096	0.1893	0.4044	0.3967
τ _i [sec] :	0.0001	0.0058	0.0602	0.3512

HVIGBT (High Voltage Insulated Gate Bipolar Transistor) MODULES



CM1500HC-66R

HIGH POWER SWITCHING USE
INSULATED TYPE

4th-Version HVIGBT (High Voltage Insulated Gate Bipolar Transistor) Modules

PERFORMANCE CURVES

REVERSE BIAS SAFE OPERATING AREA (RBSOA)

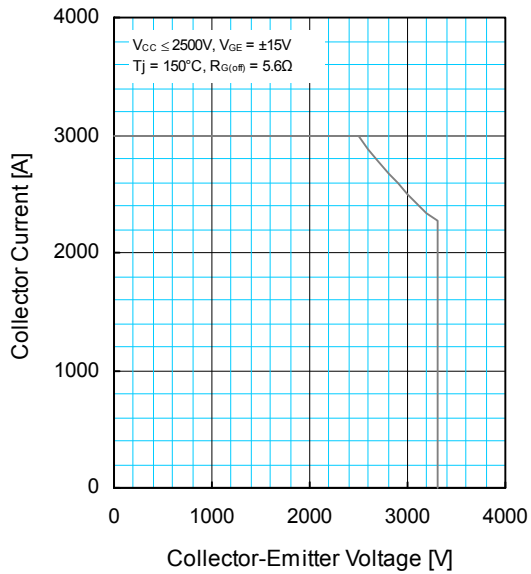

SHORT CIRCUIT SAFE OPERATING AREA (SCSOA)

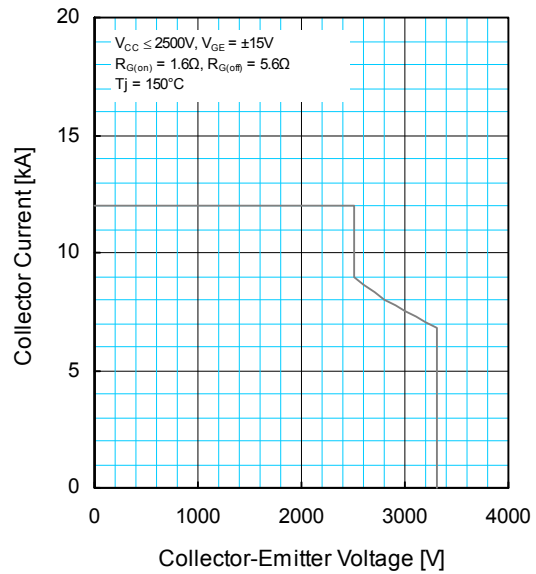

FREE-WHEEL DIODE REVERSE RECOVERY SAFE OPERATING AREA (RRSOA)

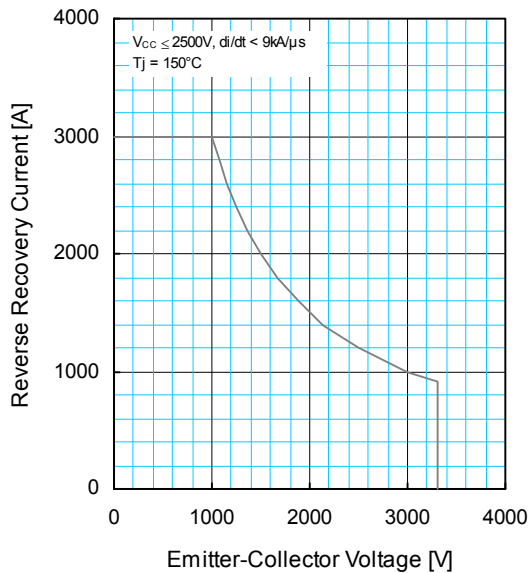

HVIGBT (High Voltage Insulated Gate Bipolar Transistor) MODULES

