

MITSUBISHI HVIGBT MODULES  
**CM800HB-50H**

2nd-Version HVIGBT (High Voltage Insulated Gate Bipolar Transistor) Modules

HIGH POWER SWITCHING USE  
**INSULATED TYPE**

**CM800HB-50H**



- Ic .....800A
- VCES .....2500V
- Insulated Type
- 1-element in a pack

**APPLICATION**

Inverters, Converters, DC choppers, Induction heating, DC to DC converters.

**OUTLINE DRAWING & CIRCUIT DIAGRAM**

Dimensions in mm

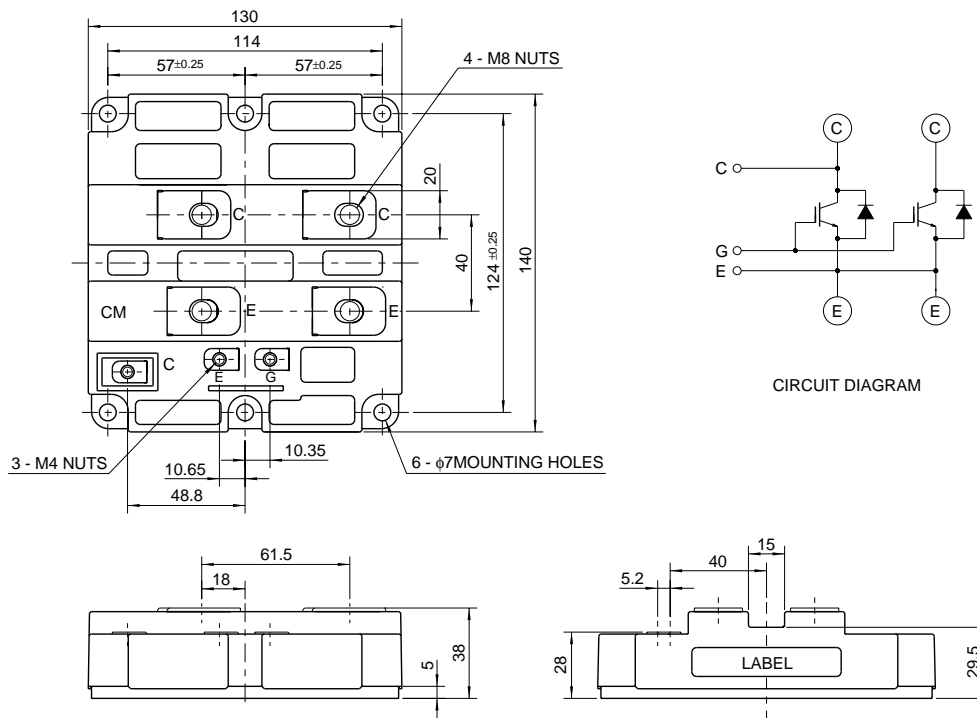

HVIGBT MODULES (High Voltage Insulated Gate Bipolar Transistor Modules)

Mar. 2003



# CM800HB-50H

HIGH POWER SWITCHING USE  
INSULATED TYPE

2nd-Version HVIGBT (High Voltage Insulated Gate Bipolar Transistor) Modules

### MAXIMUM RATINGS (Tj = 25°C)

Symbol	Item	Conditions	Ratings	Unit
VCES	Collector-emitter voltage	VGE = 0V	2500	V
VGES	Gate-emitter voltage	VCE = 0V	±20	V
IC	Collector current	DC, Tc = 110°C	800	A
ICM		Pulse (Note 1)	1600	A
IE (Note 2)	Emitter current		800	A
IEM (Note 2)		Pulse (Note 1)	1600	A
PC (Note 3)	Maximum collector dissipation	Tc = 25°C, IGBT part	10400	W
Tj	Junction temperature	—	-40 ~ +150	°C
Tstg	Storage temperature	—	-40 ~ +125	°C
Viso	Isolation voltage	Charged part to base plate, rms, sinusoidal, AC 60Hz 1min.	6000	V
—	Mounting torque	Main terminals screw M8	6.67 ~ 13.00	N·m
		Mounting screw M6	2.84 ~ 6.00	N·m
		Auxiliary terminals screw M4	0.88 ~ 2.00	N·m
—	Mass	Typical value	1.5	kg

### ELECTRICAL CHARACTERISTICS (Tj = 25°C)

Symbol	Item	Conditions	Limits			Unit
			Min	Typ	Max	
ICES	Collector cutoff current	VCE = VCES, VGE = 0V	—	—	10	mA
VGE(th)	Gate-emitter threshold voltage	IC = 80mA, VCE = 10V	4.5	6.0	7.5	V
IGES	Gate-leakage current	VGE = VGES, VCE = 0V	—	—	0.5	µA
VCE(sat)	Collector-emitter saturation voltage	Tj = 25°C	—	2.80	3.64	V
		Tj = 125°C	—	3.15	—	
Cies	Input capacitance	VCE = 10V VGE = 0V	—	120	—	nF
Coes	Output capacitance		—	13.2	—	nF
Cres	Reverse transfer capacitance		—	4.0	—	nF
QG	Total gate charge	VCC = 1250V, IC = 800A, VGE = 15V	—	5.4	—	µC
td (on)	Turn-on delay time	VCC = 1250V, IC = 800A	—	—	1.60	µs
tr	Turn-on rise time	VGE1 = VGE2 = 15V	—	—	2.00	µs
td (off)	Turn-off delay time	RG = 2.5Ω	—	—	2.50	µs
tr	Turn-off fall time	Resistive load switching operation	—	—	1.00	µs
VEC(Note 2)	Emitter-collector voltage	IE = 800A, VGE = 0V	—	2.50	3.25	V
t <sub>rr</sub> (Note 2)	Reverse recovery time	IE = 800A,	—	—	1.20	µs
Q <sub>rr</sub> (Note 2)	Reverse recovery charge	die / dt = -1600A / µs (Note 1)	—	230	—	µC
Rth(j-c)Q	Thermal resistance	Junction to case, IGBT part	—	—	0.012	K/W
Rth(j-c)R		Junction to case, FWDi part	—	—	0.024	K/W
Rth(c-f)	Contact thermal resistance	Case to fin, conductive grease applied	—	0.008	—	K/W

Note 1. Pulse width and repetition rate should be such that the device junction temp. (Tj) does not exceed Tjmax rating.

2. IE, VEC, t<sub>rr</sub>, Q<sub>rr</sub> & die/dt represent characteristics of the anti-parallel, emitter to collector free-wheel diode.

3. Junction temperature (Tj) should not increase beyond 150°C.

4. Pulse width and repetition rate should be such as to cause negligible temperature rise.

# CM800HB-50H

HIGH POWER SWITCHING USE  
INSULATED TYPE

2nd-Version HVIGBT (High Voltage Insulated Gate Bipolar Transistor) Modules

## PERFORMANCE CURVES

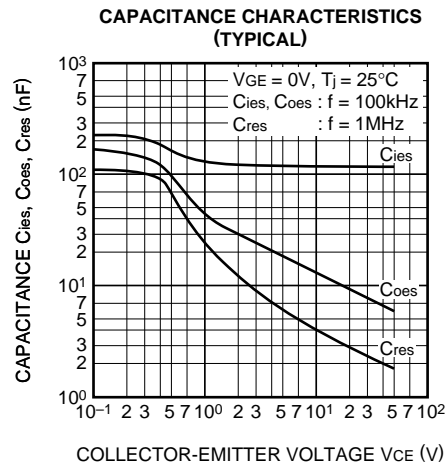
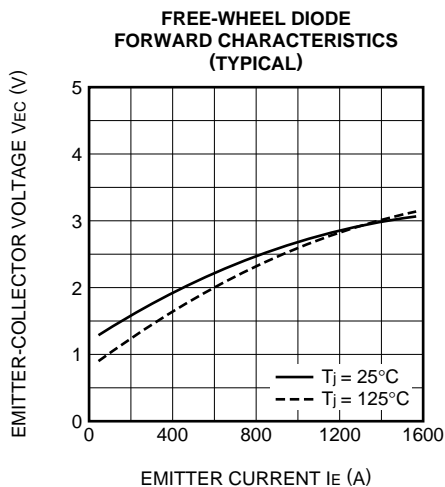
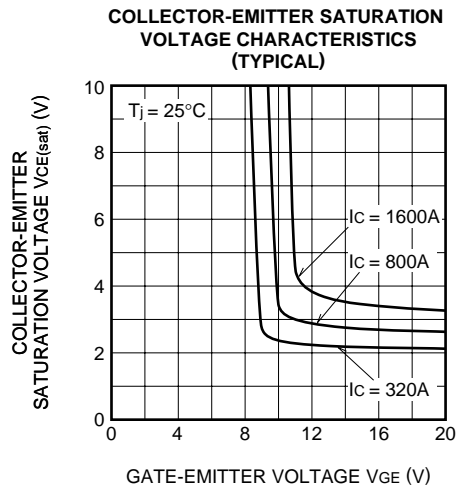
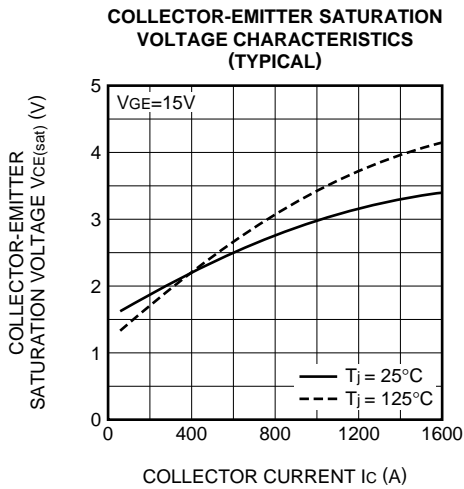
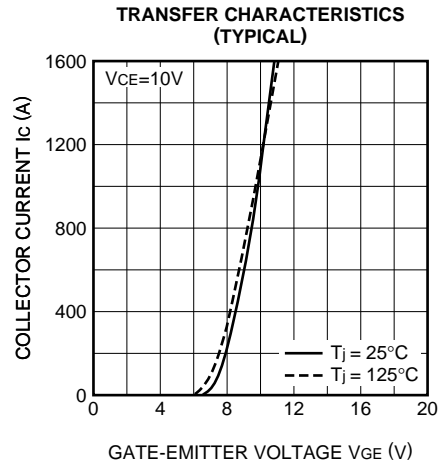
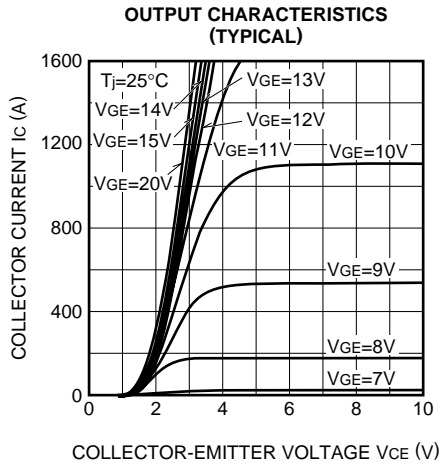

# CM800HB-50H

HIGH POWER SWITCHING USE  
INSULATED TYPE

2nd-Version HVIGBT (High Voltage Insulated Gate Bipolar Transistor) Modules

