

FEATURES

- Ideal for Server Memory applications using +5V
- Separate HVCC and LVCC capable of drive voltages from 4.0 to 13.2V for optimal system efficiency
- Adjustable thermal warning flag for phase-by-phase thermal protection
- Large drivers designed to drive 3nF in ≤ 10 ns with any voltage from 5V to 12V (typ) supplied to the HVCC and LVCC pins
 - Low-side driver – 2A source/4A sink
 - High-side driver – 2A source/2A sink
 - Transitions times & Propagation delays ≤ 10 ns
- Integrated bootstrap diode
- Capable of high switching frequencies from 200kHz up to greater than 1MHz
- Compatible with IR’s patented Active Tri-Level (ATL) PWM for fastest response to transient overshoot
- Non-overlap and under voltage protection
- Thermally enhanced 10-pin DFN package
- Lead free RoHS compliant package
- Low Quiescent power to optimize efficiency

APPLICATIONS

- Multiphase synchronous buck converter for Server CPUs and DDR Memory VR solutions
- High efficiency and compact VRM
- Optimized for Sleep state S3 systems using +5VSB
- Notebook Computer and Graphics VR solutions

DESCRIPTION

The CHL8515 MOSFET driver is a high-efficiency gate driver which can switch both high-side and low-side N-channel external MOSFETs in a synchronous buck converter. It is intended for use with IR Digital PWM controllers to provide a total voltage regulator (VR) solution for today’s advanced computing applications.

The CHL8515 driver is capable of rapidly switching large MOSFETs with low $R_{ds(on)}$ and large input capacitance used in high-efficiency designs. It is uniquely designed to operate from a 5V source, minimizing load current. It also has separate HVCC and LVCC drive inputs, capable of 4.0V to 13.2V operation. Used in conjunction with IR’s Variable Gate Drive controller feature, or a 5V standby source in sleep mode, maximum power stage efficiency can be attained.

The CHL8515 has a unique circuit which maintains drive strength to the external MOSFETs regardless of the drive voltage, insuring fast switching even at 5V as the drive voltage. The integrated boot diode reduces external component count. The CHL8515 also features an adaptive non-overlap control for shoot-through protection.

The CHL8515 is configured to drive both the high and low-side switches from the patented IR fast Active Tri-Level (ATL) PWM signal, which will optimize the turn off time of individual phases, optimizing transient performance.

Phase-by-phase thermal protection can be set from 61C to 150C with a simple resistor setting, and a thermal flag can be used to implement a thermal warning or thermal shutdown of the system by connecting OT# pins together and to the system enable in multiphase applications.

BASIC APPLICATION

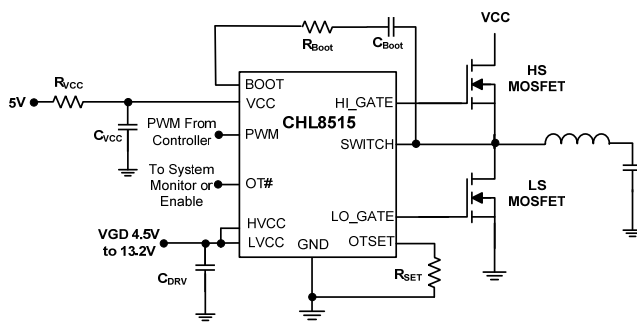

Figure 1: CHL8515 Basic Application Circuit

PIN DIAGRAM

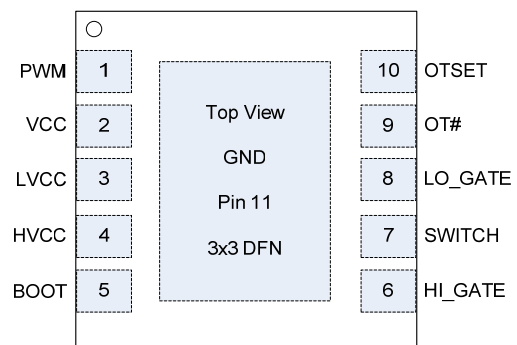
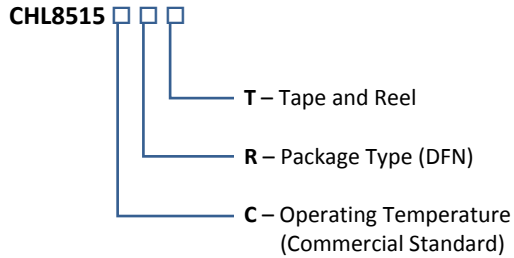

Figure 2: CHL8515 Package Top View

ORDERING INFORMATION



Package	Tape & Reel Qty	Part Number
DFN	3000	CHL8515CRT

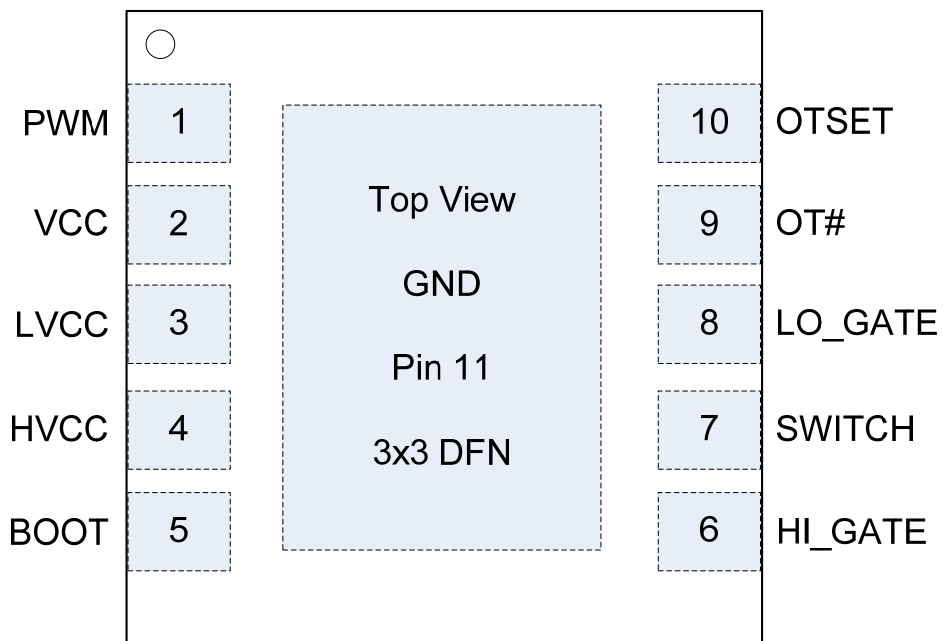

Figure 3: CHL8515 Pin Diagram Enlarged