

Thyristor

Phase leg

$$V_{RRM} = 1600 \text{ V}$$

$$I_{T(RMS)} = 79 \text{ A}$$

$$I_{T(AVM)} = 50 \text{ A}$$

Part number

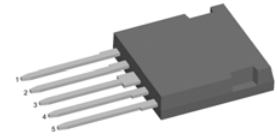
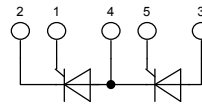
CMA 50 P 1600 FC

Backside: Isolated

E72873

Features / Advantages:

- Thyristor for line frequency
- Planar passivated chip
- Long-term stability

Applications:

- Motor control
- Power converter
- AC power controller
- Switch mode and resonant mode power supplies
- Lighting and temperature control

Package:

- Housing: i4-Pac
- DCB isolated backside
- Isolation Voltage 3000 V
- Epoxy meets UL 94V-0
- RoHS compliant

Symbol	Definition	Conditions	Ratings			Unit
			min.	typ.	max.	
V_{RSMDSM}	max. non-repetitive reverse/forward blocking voltage				1700	V
$V_{RRM/DRM}$	max. repetitive reverse/forward blocking voltage				1600	V
$I_{R/D}$	reverse current, drain current	$V_R = 1600 \text{ V}$			50	μA
		$V_R = 1600 \text{ V}$			3	mA
V_T	forward voltage	$I_T = 50 \text{ A}$			1.25	V
		$I_T = 100 \text{ A}$			1.52	V
		$I_T = 50 \text{ A}$			1.18	V
		$I_T = 100 \text{ A}$			1.48	V
$I_{T(AVM)}$	max. average forward current	$T_C = 90^\circ\text{C}$			50	A
$I_{T(RMS)}$	RMS forward current	180° sine			79	A
V_{T0}	threshold voltage	} for power loss calculation only			0.92	V
r_T	slope resistance				6.3	m Ω
R_{thJC}	thermal resistance junction to case				0.65	K/W
T_{VJ}	virtual junction temperature		-40		150	$^\circ\text{C}$
P_{tot}	total power dissipation				190	W
P_{GM}	max. gate power dissipation	$t_p = 30 \mu\text{s}$			10	W
		$t_p = 300 \mu\text{s}$			5	W
P_{GAV}	average gate power dissipation				0.5	W
I_{FSM}	max. forward surge current	$t = 10 \text{ ms}; (50 \text{ Hz}), \text{ sine}$			800	A
		$t = 8,3 \text{ ms}; (60 \text{ Hz}), \text{ sine}$			865	A
		$t = 10 \text{ ms}; (50 \text{ Hz}), \text{ sine}$			680	A
		$t = 8,3 \text{ ms}; (60 \text{ Hz}), \text{ sine}$			735	A
I^2t	value for fusing	$t = 10 \text{ ms}; (50 \text{ Hz}), \text{ sine}$			3.20	kA ² s
		$t = 8,3 \text{ ms}; (60 \text{ Hz}), \text{ sine}$			3.12	kA ² s
		$t = 10 \text{ ms}; (50 \text{ Hz}), \text{ sine}$			2.31	kA ² s
		$t = 8,3 \text{ ms}; (60 \text{ Hz}), \text{ sine}$			2.25	kA ² s
C_J	junction capacitance	$V_R = 400 \text{ V}$ $f = 1 \text{ MHz}$			32	pF

Symbol	Definition	Conditions	Ratings			Unit
			min.	typ.	max.	
$(di/dt)_cr$	critical rate of rise of current	$T_{VJ} = 125^{\circ}\text{C}$ repetitive, $I_T = 150\text{ A}$ $f = 50\text{ Hz}$; $t_p = 200\ \mu\text{s}$ $I_G = 0.45\text{ A}$; $di_G/dt = 0.3\text{ A}/\mu\text{s}$			150	$\text{A}/\mu\text{s}$
		$V_D = \frac{2}{3} V_{DRM}$ non-repetitive, $I_T = 22\text{ A}$			500	$\text{A}/\mu\text{s}$
$(dv/dt)_cr$	critical rate of rise of voltage	$V_D = \frac{2}{3} V_{DRM}$ $T_{VJ} = 125^{\circ}\text{C}$ $R_{GK} = \infty$; method 1 (linear voltage rise)			1000	$\text{V}/\mu\text{s}$
V_{GT}	gate trigger voltage	$V_D = 6\text{ V}$ $T_{VJ} = 25^{\circ}\text{C}$ $T_{VJ} = -40^{\circ}\text{C}$			1.4	V
I_{GT}	gate trigger current	$V_D = 6\text{ V}$ $T_{VJ} = 25^{\circ}\text{C}$ $T_{VJ} = -40^{\circ}\text{C}$			1.6	V
					80	mA
					120	mA
V_{GD}	gate non-trigger voltage	$V_D = \frac{2}{3} V_{DRM}$ $T_{VJ} = 150^{\circ}\text{C}$			0.2	V
I_{GD}	gate non-trigger current				5	mA
I_L	latching current	$t_p = 10\ \mu\text{s}$ $T_{VJ} = 25^{\circ}\text{C}$ $I_G = 0.3\text{ A}$; $di_G/dt = 0.3\text{ A}/\mu\text{s}$			450	mA
I_H	holding current	$V_D = 6\text{ V}$ $R_{GK} = \infty$ $T_{VJ} = 25^{\circ}\text{C}$			100	mA
t_{gd}	gate controlled delay time	$V_R = \frac{1}{2} V_{DRM}$ $T_{VJ} = 25^{\circ}\text{C}$ $I_G = 0.5\text{ A}$; $di_G/dt = 0.5\text{ A}/\mu\text{s}$			2	μs
t_q	turn-off time	$V_R = 100\text{ V}$; $I_T = 20\text{ A}$ $T_{VJ} = 150^{\circ}\text{C}$ $V_D = \frac{2}{3} V_{DRM}$; $t_p = 200\ \mu\text{s}$ $di/dt = 10\text{ A}/\mu\text{s}$; $dv/dt = 20\text{ V}/\mu\text{s}$		150		μs

Symbol	Definition	Conditions	Ratings			Unit
			min.	typ.	max.	
I_{RMS}	RMS current	per terminal ¹⁾			70	A
R_{thCH}	thermal resistance case to heatsink			0.20		K/W
T_{stg}	storage temperature		-55		150	°C
Weight				9		g
F_C	mounting force with clip		20		120	N
V_{ISOL}	isolation voltage	t = 1 second	3600			V
		t = 1 minute	3000			V
d_s	creepage distance on surface		1.7			mm
d_A	striking distance through air		5.5			mm

¹⁾ I_{RMS} is typically limited by: 1. terminal-to-chip resistance; or by 2. current capability of the chip.
 In case of 1, a common cathode/anode configuration and a non-isolated backside, the whole current capability can be used by connecting the backside.

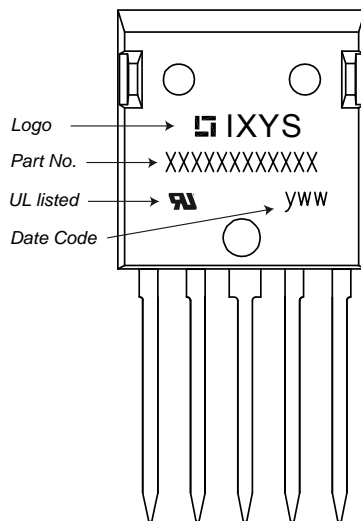
Product Marking

Part number

C = Thyristor (SCR)
 M = Thyristor
 A = (up to 1800 V)
 50 = Current Rating [A]
 P = Phase leg
 1600 = Reverse Voltage [V]
 FC = i4-Pac (5)

Ordering	Part Name	Marking on Product	Delivering Mode	Base Qty	Code Key
Standard	CMA 50 P 1600 FC	CMA50P1600FC	Tube	24	507603

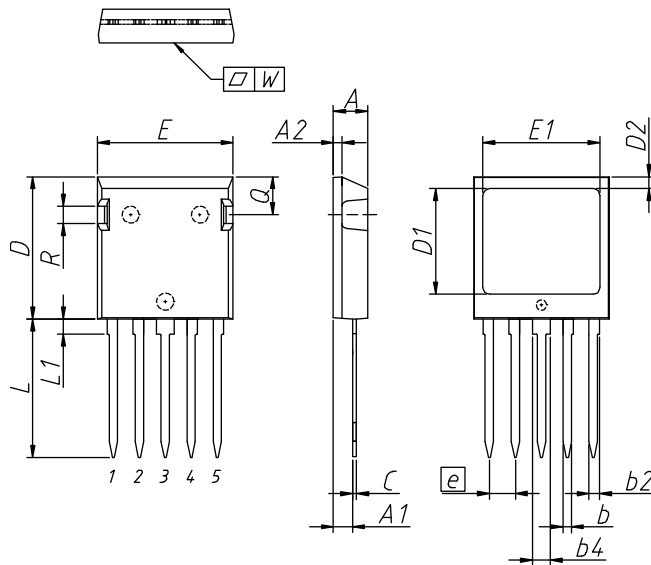
Similar Part	Package	Voltage class
CMA30P1600FC	i4-Pac (5)	1600

Outlines i4-Pac

DIM.	MILLIMETER		INCHES	
	MIN	MAX	MIN	MAX
A	4,83	5,21	0,190	0,205
A1	2,59	3,00	0,102	0,118
A2	1,17	2,16	0,046	0,085
b	1,14	1,40	0,045	0,055
b2	1,47	1,73	0,058	0,068
b4	2,54	2,79	0,100	0,110
C	0,51	0,74	0,020	0,029
D	20,80	21,34	0,819	0,840
D1	14,99	15,75	0,590	0,620
D2	1,65	2,03	0,065	0,080
E	19,56	20,29	0,770	0,799
E1	16,76	17,53	0,660	0,690
e	3,81 BSC		0,15 BSC	
L	19,81	21,34	0,780	0,840
L1	2,11	2,59	0,083	0,102
Q	5,33	6,20	0,210	0,244
R	2,54	4,57	0,100	0,180
W	-	0,10	-	0,004

Die konvexe Form des Substrates ist typ. < 0.05 mm über der Kunststoffoberfläche der Bauteilunterseite
 The convex bow of substrate is typ. < 0.05 mm over plastic surface level of device bottom side