

## Standard Rectifier

<b>3 ~ Rectifier</b>	
$V_{RRM}$	= 800 V
$I_{DAV}$	= 40 A
$I_{FSM}$	= 370 A

### 3~ Rectifier Bridge

Part number

GUO40-08NO1

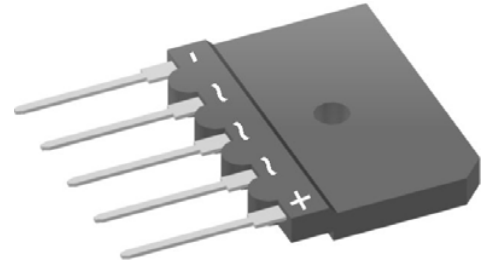

Backside: isolated

 E326641

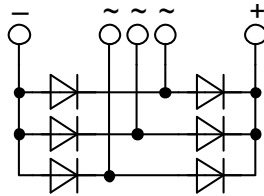

#### Features / Advantages:

- Low forward voltage drop
- Planar passivated chips
- Easy to mount with one screw
- Space and weight savings

#### Applications:

- Supplies for DC power equipment
- Input rectifiers for PWM inverter
- Battery DC power supplies
- Field supply for DC motors

#### Package:

- Housing: GUPF
- Industry standard outline
- Plastic overmolded tab for electrical isolation
- Isolation Voltage 2500 V
- Epoxy meets UL 94V-0
- RoHS compliant

Rectifier				Ratings				
Symbol	Definition	Conditions		min.	typ.	max.	Unit	
$V_{RSM}$	max. non-repetitive reverse blocking voltage		$T_{VJ} = 25^{\circ}\text{C}$			900	V	
$V_{RRM}$	max. repetitive reverse blocking voltage		$T_{VJ} = 25^{\circ}\text{C}$			800	V	
$I_R$	reverse current, drain current	$V_R = 800\text{ V}$	$T_{VJ} = 25^{\circ}\text{C}$			50	$\mu\text{A}$	
		$V_R = 800\text{ V}$	$T_{VJ} = 150^{\circ}\text{C}$			1.5	mA	
$V_F$	forward voltage drop	$I_F = 12.5\text{ A}$	$T_{VJ} = 25^{\circ}\text{C}$			1.15	V	
						1.30	V	
		$I_F = 25\text{ A}$	$T_{VJ} = 125^{\circ}\text{C}$			1.05	V	
						1.20	V	
$I_{DAV}$	bridge output current	$T_C = 85^{\circ}\text{C}$ 120° sine	$T_{VJ} = 175^{\circ}\text{C}$			40	A	
$V_{FO}$	threshold voltage		$T_{VJ} = 175^{\circ}\text{C}$			0.86	V	
$r_F$	slope resistance					12.9	m $\Omega$	
$R_{thJC}$	thermal resistance junction to case					4.30	K/W	
$R_{thCH}$	thermal resistance case to heatsink				0.50		K/W	
$P_{tot}$	total power dissipation		$T_C = 25^{\circ}\text{C}$			35	W	
$I_{FSM}$	max. forward surge current	$t = 10\text{ ms}; (50\text{ Hz}), \text{ sine}$	$T_{VJ} = 45^{\circ}\text{C}$			370	A	
						400	A	
		$t = 8,3\text{ ms}; (60\text{ Hz}), \text{ sine}$	$T_{VJ} = 175^{\circ}\text{C}$	$V_R = 0\text{ V}$			315	A
							340	A
$I^2t$	value for fusing	$t = 10\text{ ms}; (50\text{ Hz}), \text{ sine}$	$T_{VJ} = 45^{\circ}\text{C}$			685	A <sup>2</sup> s	
						665	A <sup>2</sup> s	
		$t = 8,3\text{ ms}; (60\text{ Hz}), \text{ sine}$	$T_{VJ} = 175^{\circ}\text{C}$	$V_R = 0\text{ V}$			495	A <sup>2</sup> s
							480	A <sup>2</sup> s
$C_J$	junction capacitance	$V_R = 400\text{ V}$ $f = 1\text{ MHz}$	$T_{VJ} = 25^{\circ}\text{C}$		11		pF	

Package GUPP		Ratings				
Symbol	Definition	Conditions	min.	typ.	max.	Unit
$I_{RMS}$	RMS current	per terminal			70	A
$T_{stg}$	storage temperature		-55		150	°C
$T_{vj}$	virtual junction temperature		-40		175	°C
<b>Weight</b>				8.5		g
$M_D$	mounting torque		0.8		1.2	Nm
$F_C$	mounting force with clip		20		120	N
$V_{ISOL}$	isolation voltage	t = 1 second	2500			V
		t = 1 minute	2000			V
$d_{Spp/App}$	creepage distance on surface   striking distance through air	terminal to terminal	6.7	5.4		mm
$d_{Spb/Apb}$		terminal to backside	10.0	8.0		mm

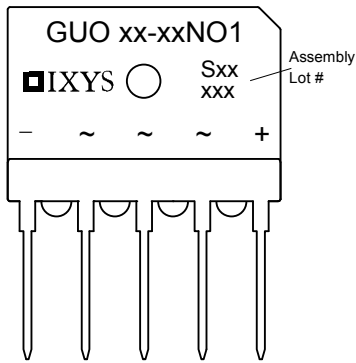

Ordering	Part Number	Marking on Product	Delivery Mode	Quantity	Code No.
Standard	GUO40-08NO1	GUO40-08NO1	Tube	15	509523

Similar Part	Package	Voltage class
GUO40-16NO1	GUPP	1600
GUO40-12NO1	GUPP	1200

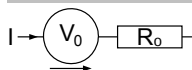
**Equivalent Circuits for Simulation**
 $T_{vj} = 175^{\circ}C$ 

**Rectifier**

$V_{0\max}$	threshold voltage	0.86	V
$R_{0\max}$	slope resistance	10.3	mΩ

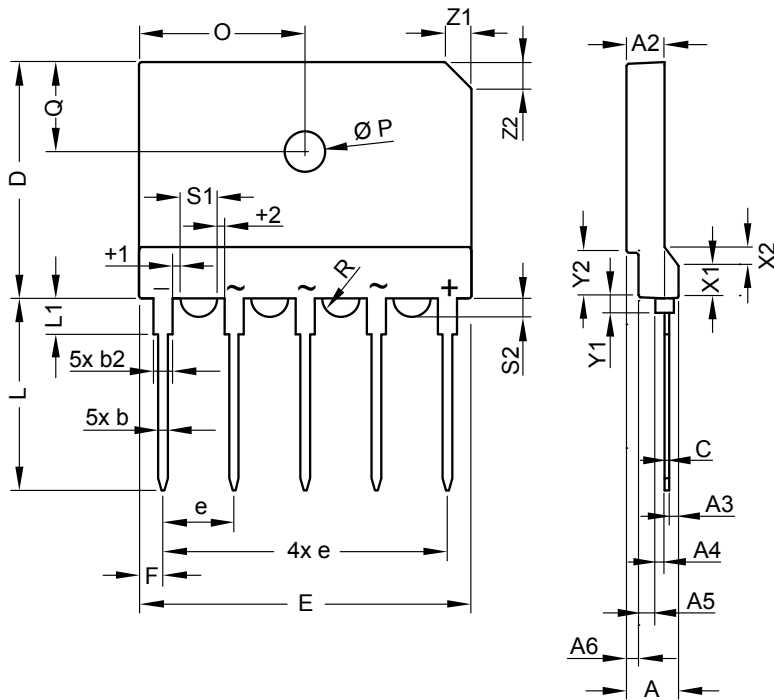
**Outlines GUPF**

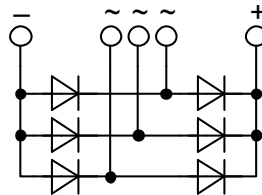

Dim.	Millimeter			Inches		
	min	typ.	max	min	typ.	max
A	5.40	5.50	5.60	0.213	0.217	0.221
A2	3.90	4.00	4.10	0.154	0.158	0.162
A3	0.95	1.00	1.10	0.037	0.039	0.043
A4	0.95	1.00	1.05	0.037	0.039	0.041
A5	1.60	1.70	1.80	0.063	0.067	0.071
A6	1.25	1.30	1.35	0.049	0.051	0.053
b	0.95	1.00	1.05	0.037	0.039	0.041
b2	1.95	2.00	2.05	0.077	0.079	0.081
C	0.45	0.50	0.55	0.018	0.020	0.022
D	24.80	25.00	25.20	0.977	0.985	0.993
E	34.70	35.00	35.30	1.367	1.379	1.391
e	BSC 7.50			BSC 0.296		
F	2.40	2.50	2.60	0.095	0.099	0.102
L	20.30	20.40	20.50	0.800	0.804	0.808
L1	3.70	3.75	3.80	0.146	0.148	0.150
O	17.40	17.50	17.60	0.686	0.690	0.693
$\varnothing P$	4.10	4.20	4.30	0.162	0.165	0.169
Q	9.20	9.30	9.40	0.362	0.366	0.370
$\varnothing_{1/2} R$	1.77			0.070		
s1	3.45	3.50	3.55	0.136	0.138	0.140
s2	1.45	1.50	1.55	0.057	0.059	0.061
t1	0.95	1.00	1.05	0.037	0.039	0.041
t2	0.95	1.00	1.05	0.037	0.039	0.041
x1	3.20	3.30	3.40	0.126	0.130	0.134
x2	1.90	2.00	2.10	0.075	0.079	0.083
y1	1.60	1.65	1.70	0.063	0.065	0.067
y2	4.65	4.70	4.75	0.183	0.185	0.187
z1	2.80	2.90	3.00	0.110	0.114	0.118



Rectifier

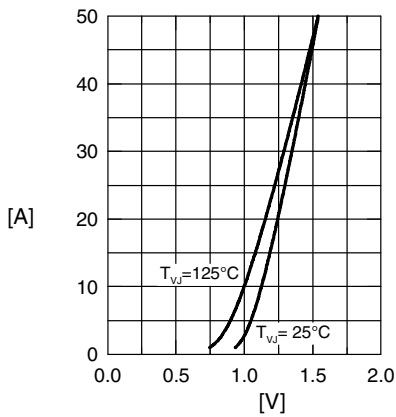

Fig. 1 Forward current versus voltage drop per diode

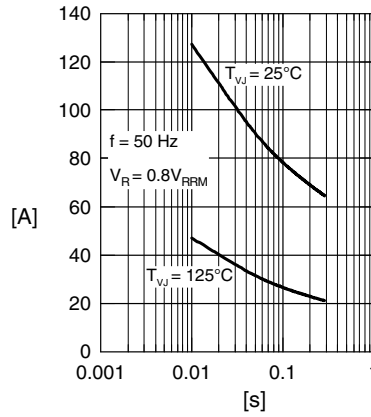

Fig. 2 Surge overload current

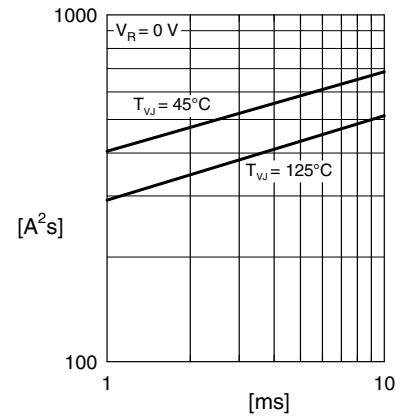

Fig. 3  $I^2t$  versus time per diode

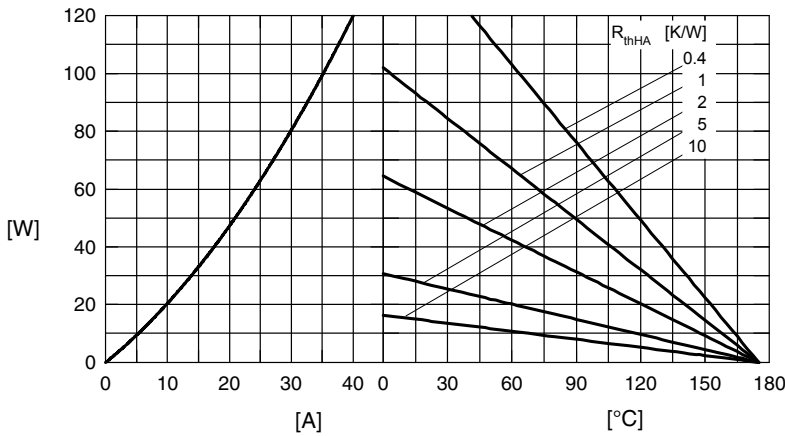

Fig. 4 Power dissipation versus direct output current and ambient temperature, sine 180°

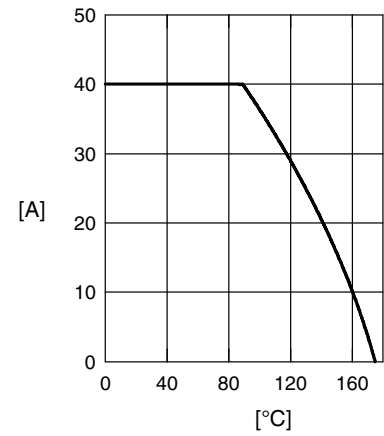

Fig. 5 Max. forward current vs. case temperature

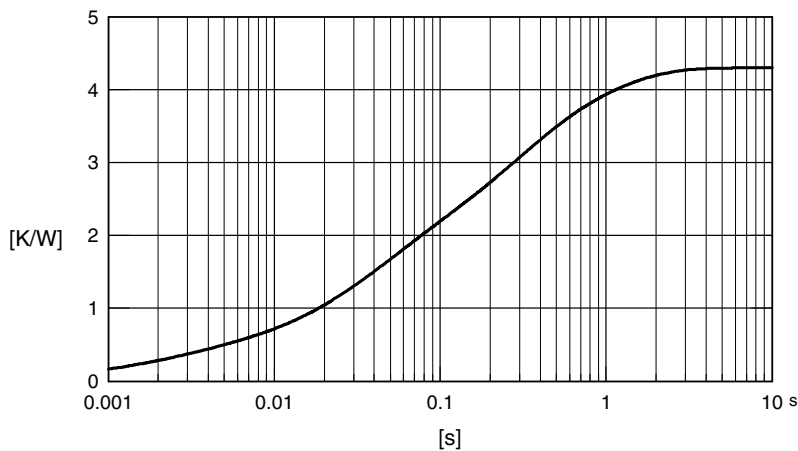

Fig. 6 Transient thermal impedance junction to case

Constants for  $Z_{thJC}$  calculation:

i	$R_{thi}$ [K/W]	$t_i$ [s]
1	0.302	0.002
2	1.252	0.032
3	1.582	0.227
4	1.164	0.82