

# HiPerFRED<sup>2</sup>

High Performance Fast Recovery Diode  
Low Loss and Soft Recovery  
Phase leg

$V_{RRM} = 300\text{ V}$   
 $I_{FAV} = 30\text{ A}$   
 $t_{rr} = 35\text{ ns}$

Part number

**DPG 30 P 300 PJ**

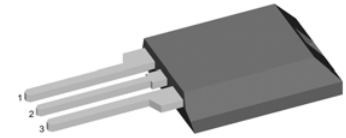
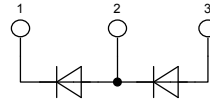

Backside: isolated

E72873

### Features / Advantages:

- Planar passivated chips
- Very low leakage current
- Very short recovery time
- Improved thermal behaviour
- Very low  $I_{RM}$ -values
- Very soft recovery behaviour
- Avalanche voltage rated for reliable operation
- Soft reverse recovery for low EMI/RFI
- Low  $I_{RM}$  reduces:
  - Power dissipation within the diode
  - Turn-on loss in the commutating switch

### Applications:

- Antiparallel diode for high frequency switching devices
- Antisaturation diode
- Snubber diode
- Free wheeling diode
- Rectifiers in switch mode power supplies (SMPS)
- Uninterruptible power supplies (UPS)

### Package:

- Housing: ISOPLUS220
- Industry standard outline
- DCB isolated backside
- Isolation Voltage 3000 V
- Epoxy meets UL 94V-0
- RoHS compliant

### Ratings

Symbol	Definition	Conditions	min.	typ.	max.	Unit
$V_{RRM}$	max. repetitive reverse voltage				300	V
$I_R$	reverse current	$V_R = 300\text{ V}$			1	$\mu\text{A}$
		$V_R = 300\text{ V}$			0.2	mA
$V_F$	forward voltage	$I_F = 30\text{ A}$			1.28	V
		$I_F = 60\text{ A}$			1.58	V
		$I_F = 30\text{ A}$			0.99	V
		$I_F = 60\text{ A}$			1.32	V
$I_{FAV}$	average forward current	rectangular d = 0.5			30	A
$V_{FO}$	threshold voltage	} for power loss calculation only			0.60	V
$r_F$	slope resistance				11	m $\Omega$
$R_{thJC}$	thermal resistance junction to case				1.05	K/W
$T_{VJ}$	virtual junction temperature		-55		175	$^{\circ}\text{C}$
$P_{tot}$	total power dissipation				145	W
$I_{FSM}$	max. forward surge current	t = 10 ms (50 Hz), sine			450	A
$I_{RM}$	max. reverse recovery current				3	A
		$I_F = 30\text{ A}; V_R = 200\text{ V}$			8.5	A
$t_{rr}$	reverse recovery time	-di <sub>F</sub> /dt = 200 A/ $\mu\text{s}$			35	ns
					65	ns
$C_J$	junction capacitance	$V_R = 200\text{ V}; f = 1\text{ MHz}$			60	pF

Symbol	Definition	Conditions	Ratings			Unit
			min.	typ.	max.	
$I_{RMS}$	RMS current	per terminal			35	A
$R_{thCH}$	thermal resistance case to heatsink			0.50		K/W
$T_{stg}$	storage temperature		-55		150	°C
<b>Weight</b>				2		g
$F_C$	mounting force with clip		20		60	N
$V_{ISOL}$	isolation voltage	t = 1 second	3600			V
		t = 1 minute	3000			V
$d_{Spp/App}$	creepage   striking distance on surface   through air	terminal to terminal	1.0			mm
$d_{Spb/Apb}$	creepage   striking distance on surface   through air	terminal to backside	3.0			mm

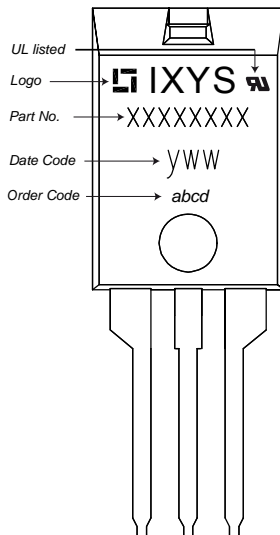
**Product Marking**

**Part number**

- D = Diode
- P = HiPerFRED
- G = extreme fast
- 30 = Current Rating [A]
- P = Phase leg
- 300 = Reverse Voltage [V]
- PJ = ISOPLUS220AB (3)

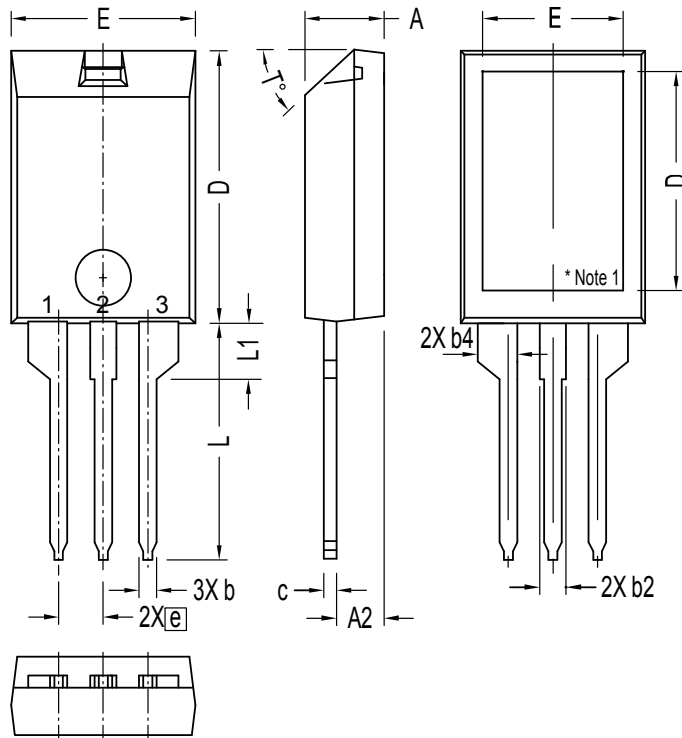
Ordering	Part Name	Marking on Product	Delivering Mode	Base Qty	Code Key
Standard	DPG 30 P 300 PJ	DPG30P300PJ	Tube	50	508134

**Outlines ISOPLUS220**

SYM	INCHES		MILLIMETERS	
	MIN	MAX	MIN	MAX
A	.157	.197	4.00	5.00
A2	.098	.118	2.50	3.00
b	.035	.051	0.90	1.30
b2	.049	.065	1.25	1.65
b4	.093	.100	2.35	2.55
c	.028	.039	0.70	1.00
D	.591	.630	15.00	16.00
D1	.472	.512	12.00	13.00
E	.394	.433	10.00	11.00
E1	.295	.335	7.50	8.50
e	.100 BASIC		2.55	BASIC
L	.512	.571	13.00	14.50
L1	.118	.138	3.00	3.50
T°			42.5°	47.5°

**NOTE:**

1. Bottom heatsink is electrically isolated from Pin 1, 2, or 3.
2. This drawing will meet dimensional requirement of JEDEC SS Product Outline TO-273 except D and D1 dimension.

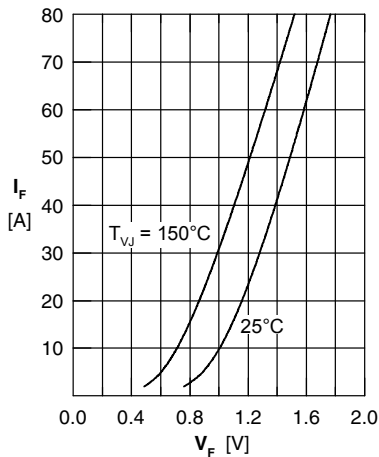

Fig. 1 Forward current  $I_F$  versus forward voltage  $V_F$

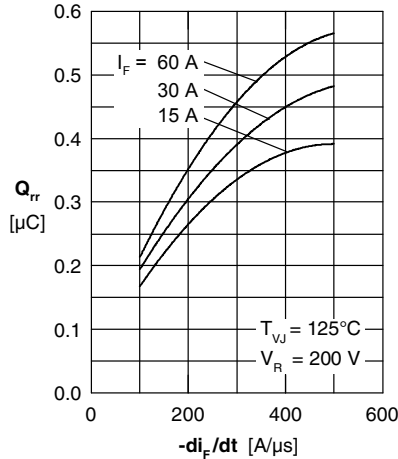

Fig. 2 Typ. reverse recovery charge  $Q_{rr}$  versus  $-di_F/dt$

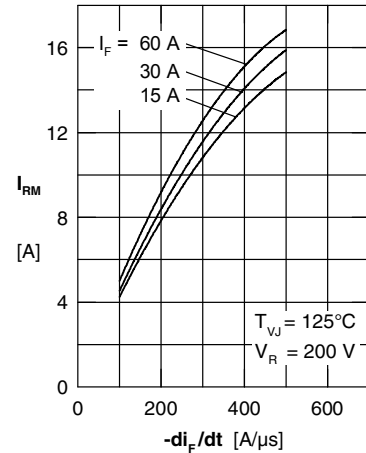

Fig. 3 Typ. reverse recovery current  $I_{RM}$  versus  $-di_F/dt$

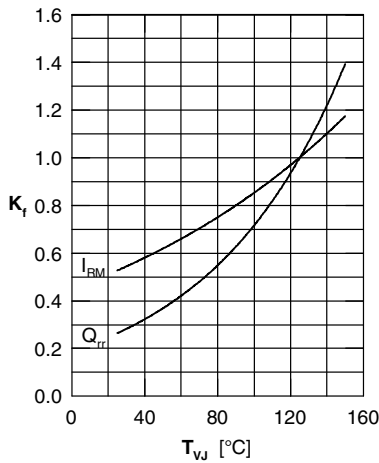

Fig. 4 Dynamic parameters  $Q_{rr}$ ,  $I_{RM}$  versus  $T_{VJ}$

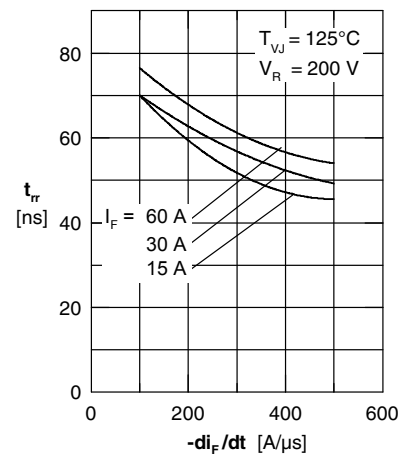

Fig. 5 Typ. reverse recovery time  $t_{rr}$  versus  $-di_F/dt$

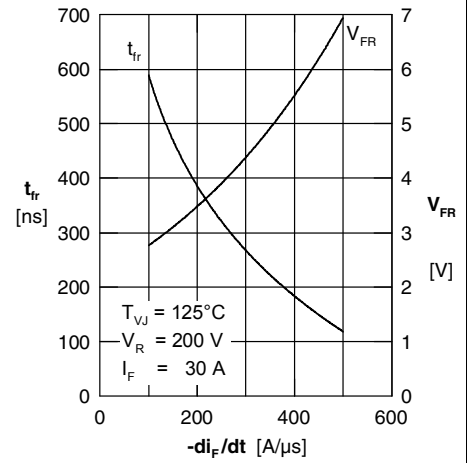

Fig. 6 Typ. forward recovery voltage  $V_{FR}$  & forward recovery time  $t_{fr}$  vs.  $di_F/dt$

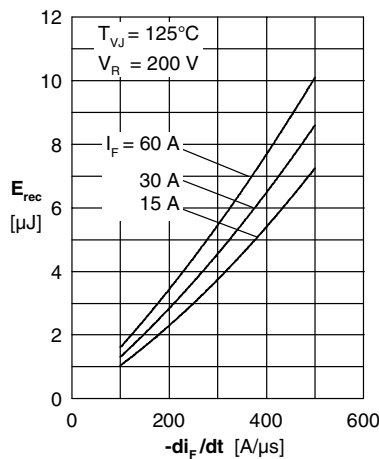

Fig. 7 Typ. recovery energy  $E_{rec}$  versus  $-di_F/dt$

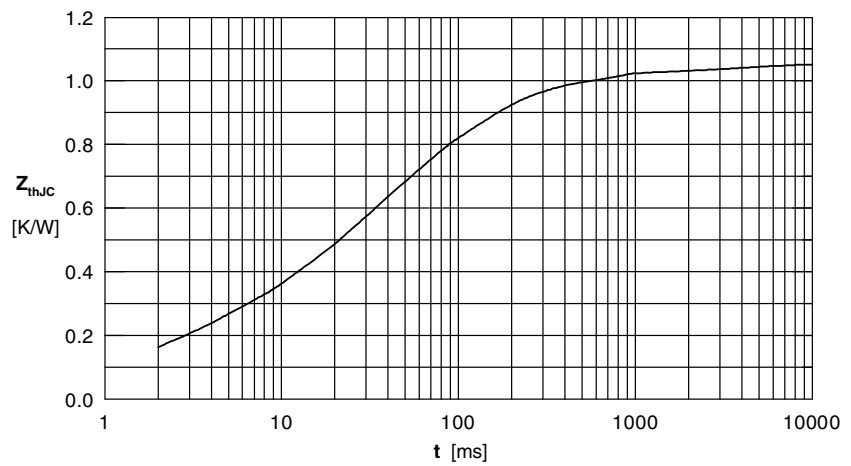

Fig. 8 Transient thermal impedance junction to case