

IGBT XPT Module

H Bridge

$$V_{CES} = 1200 \text{ V}$$

$$I_{C25} = 85 \text{ A}$$

$$V_{CE(sat)} = 1.8 \text{ V}$$

Preliminary data

Part name (Marking on product)

MIXA 61H1200ED

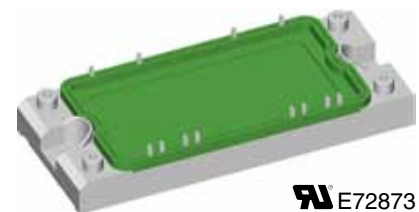
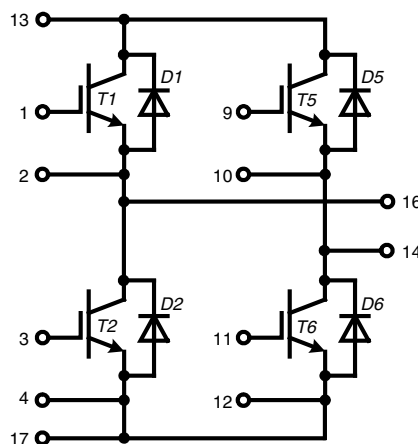

E72873

Features:

- Easy paralleling due to the positive temperature coefficient of the on-state voltage
- Rugged XPT design (Xtreme light Punch Through) results in:
 - short circuit rated for 10 μ sec.
 - very low gate charge
 - square RBSOA @ 3x I_C
 - low EMI
- Thin wafer technology combined with the XPT design results in a competitive low $V_{CE(sat)}$
- SONIC™ diode
 - fast and soft reverse recovery
 - low operating forward voltage

Application:

- AC motor drives
- Solar inverter
- Medical equipment
- Uninterruptible power supply
- Air-conditioning systems
- Welding equipment
- Switched-mode and resonant-mode power supplies

Package:

- "E2-Pack" standard outline
- Insulated copper base plate
- Soldering pins for PCB mounting

Output Inverter T1 - T6

Symbol	Definitions	Conditions	Ratings			Unit
			min.	typ.	max.	
V_{CES}	collector emitter voltage				1200	V
V_{GES}	max. DC gate voltage	continuous			±20	V
V_{GEM}	max. transient collector gate voltage	transient			±30	V
I_{C25}	collector current				85	A
I_{C80}					60	A
P_{tot}	total power dissipation				290	W
$V_{CE(sat)}$	collector emitter saturation voltage	$I_C = 55 \text{ A}; V_{GE} = 15 \text{ V}$		1.8	2.1	V
				2.1		V
$V_{GE(th)}$	gate emitter threshold voltage	$I_C = 2 \text{ mA}; V_{GE} = V_{CE}$		5.4	6.0	V
I_{CES}	collector emitter leakage current	$V_{CE} = V_{CES}; V_{GE} = 0 \text{ V}$			0.5	mA
					0.2	mA
I_{GES}	gate emitter leakage current	$V_{GE} = \pm 20 \text{ V}$			500	nA
$Q_{G(on)}$	total gate charge	$V_{CE} = 600 \text{ V}; V_{GE} = 15 \text{ V}; I_C = 50 \text{ A}$			165	nC
$t_{d(on)}$	turn-on delay time	inductive load $V_{CE} = 600 \text{ V}; I_C = 50 \text{ A}$ $V_{GE} = \pm 15 \text{ V}; R_G = 15 \Omega$	$T_{VJ} = 125^\circ\text{C}$		70	ns
t_r	current rise time				40	ns
$t_{d(off)}$	turn-off delay time				250	ns
t_f	current fall time				100	ns
E_{on}	turn-on energy per pulse				4.5	mJ
E_{off}	turn-off energy per pulse				5.5	mJ
RBSOA	reverse bias safe operating area	$V_{GE} = \pm 15 \text{ V}; R_G = 15 \Omega;$			150	A
SCSOA	short circuit safe operating area					
t_{SC}	short circuit duration	$V_{CE} = 900 \text{ V}; V_{GE} = \pm 15 \text{ V};$			10	μs
I_{SC}	short circuit current	$R_G = 15 \Omega;$ non-repetitive		200		A
R_{thJC}	thermal resistance junction to case	(per IGBT)			0.43	K/W

Output Inverter D1 - D6

Symbol	Definitions	Conditions	Ratings			Unit
			min.	typ.	max.	
V_{RRM}	max. repetitive reverse voltage				1200	V
I_{F25}	forward current				85	A
I_{F80}					57	A
V_F	forward voltage	$I_F = 60 \text{ A}; V_{GE} = 0 \text{ V}$		1.95	2.2	V
				1.95		V
Q_{rr}	reverse recovery charge	$V_R = 600 \text{ V}$ $di_f/dt = -1200 \text{ A}/\mu\text{s}$ $I_F = 60 \text{ A}; V_{GE} = 0 \text{ V}$	$T_{VJ} = 125^\circ\text{C}$		8	μC
I_{RM}	max. reverse recovery current				60	A
t_{rr}	reverse recovery time				350	ns
E_{rec}	reverse recovery energy				2.5	mJ
R_{thJC}	thermal resistance junction to case	(per diode)			0.6	K/W

$T_C = 25^\circ\text{C}$ unless otherwise stated

Module

Symbol	Definitions	Conditions	Ratings			Unit
			min.	typ.	max.	
T_{VJ}	operating temperature		-40		125	°C
T_{VJM}	max. virtual junction temperature				150	°C
T_{stg}	storage temperature		-40		125	°C
V_{ISOL}	isolation voltage	$I_{ISOL} \leq 1 \text{ mA}; 50/60 \text{ Hz}$			3000	V~
CTI	comparative tracking index				-	
M_d	mounting torque (M5)		3		6	Nm
d_s	creep distance on surface		6			mm
d_A	strike distance through air		6			mm
$R_{pin-chip}$	resistance pin to chip			5		mΩ
R_{thCH}	thermal resistance case to heatsink	with heatsink compound		0.02		K/W
Weight				180		g

Equivalent Circuits for Simulation

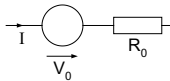

Symbol	Definitions	Conditions	min.	Ratings		Unit
				typ.	max.	
V_0	IGBT	T1 - T6		1.1		V
R_0				25.1		mΩ
V_0	free wheeling diode	D1 - D6		1.22		V
R_0				12.99		mΩ

$T_c = 25^\circ\text{C}$ unless otherwise stated

Circuit Diagram

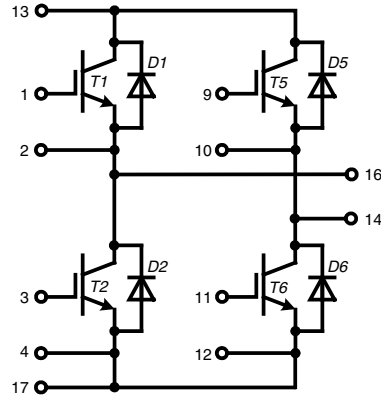

Outline Drawing

Dimensions in mm (1 mm = 0.0394")

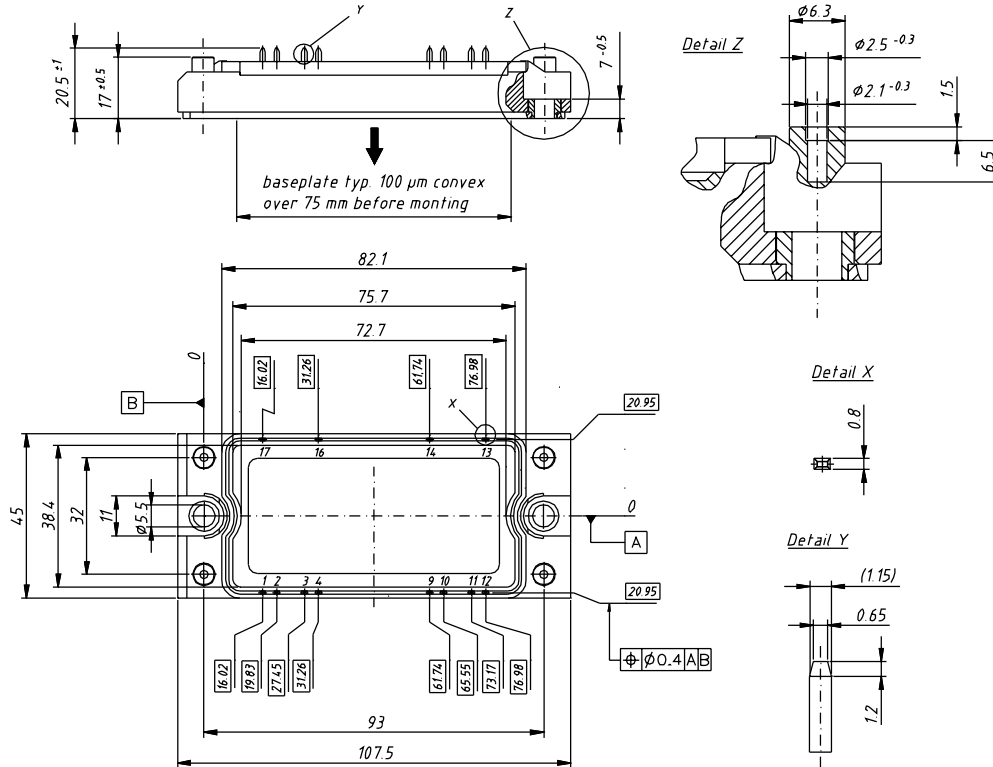

Product Marking

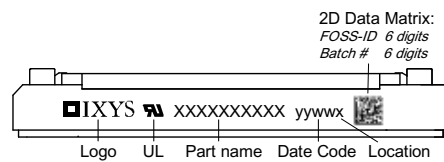

Part number

- M = Module
- I = IGBT
- X = XPT
- A = standard
- 61 = Current Rating [A]
- H = H- Bridge
- 1200 = Reverse Voltage [V]
- ED = E2-Pack

Ordering	Part Name	Marking on Product	Delivering Mode	Base Qty	Ordering Code
Standard	MIXA61H1200ED	MIXA61H1200ED	Box	6	511060

IXYS reserves the right to change limits, test conditions and dimensions.

20110509a

© 2011 IXYS All rights reserved

4 - 6

Inverter T1 - T6

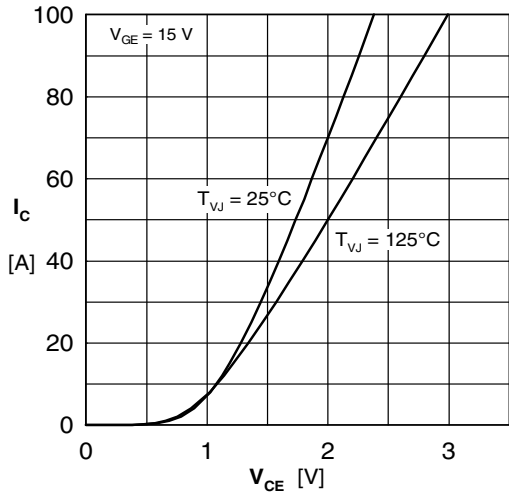

Fig. 1 Typ. output characteristics

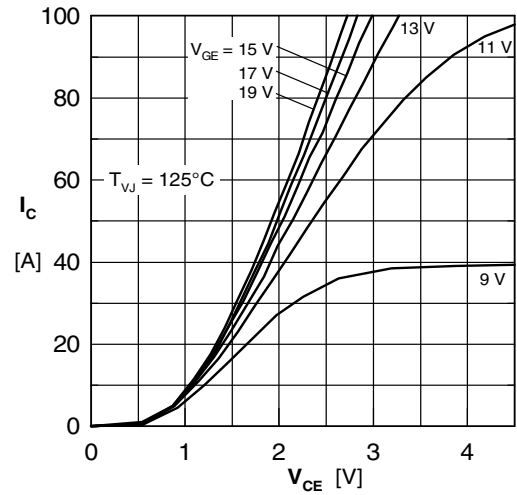

Fig. 2 Typ. output characteristics

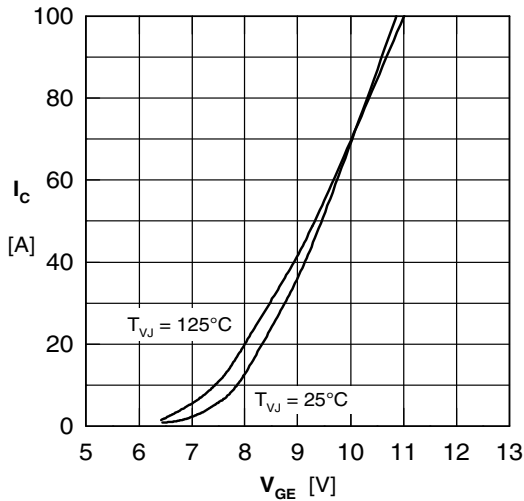

Fig. 3 Typ. transfer characteristics

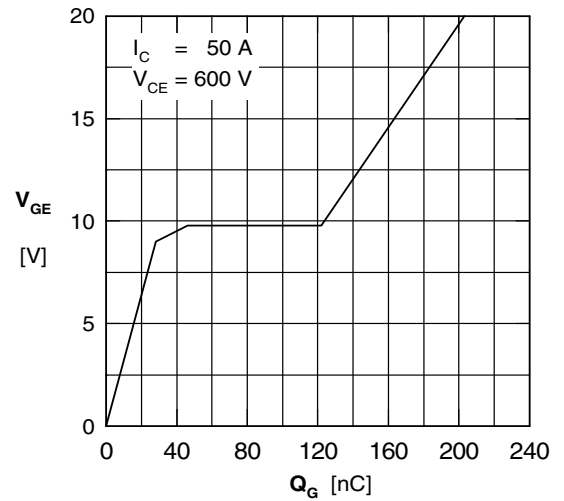

Fig. 4 Typ. turn-on gate charge

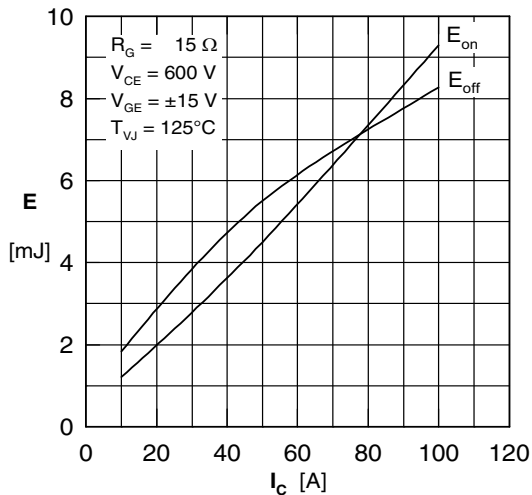

Fig. 5 Typ. switching energy vs. collector current

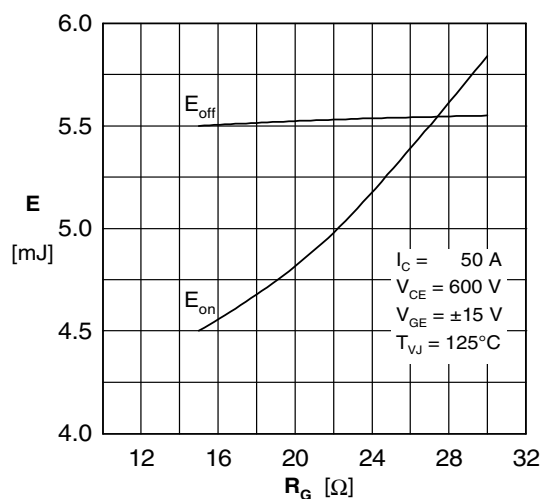

Fig. 6 Typ. switching energy vs. gate resistance

IXYS reserves the right to change limits, test conditions and dimensions.

20110509a

Inverter D1 - D6

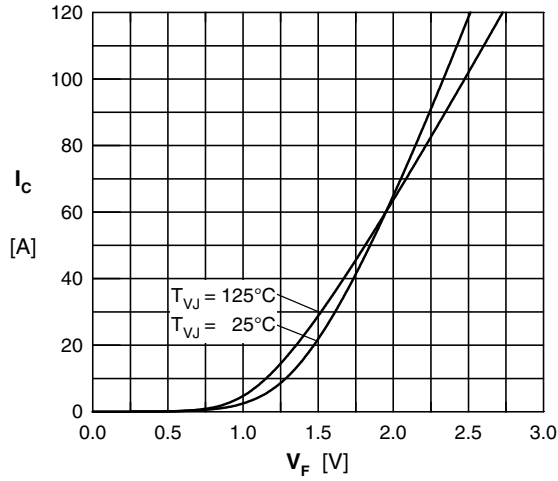

Fig. 7 Typ. Forward current versus V_F

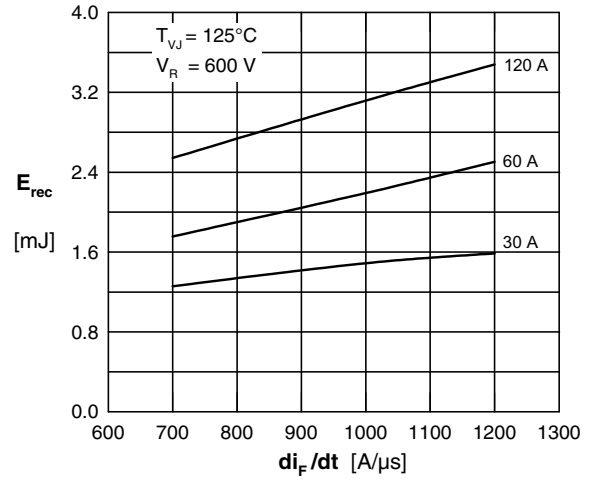

Fig. 8 Typ. recovery energy E_{rec} versus di/dt

	IGBT		FRD	
	R_i	τ_i	R_i	τ_i
1	0.1	0.0025	0.137	0.0025
2	0.05	0.03	0.1	0.03
3	0.21	0.03	0.233	0.03
4	0.07	0.08	0.13	0.08

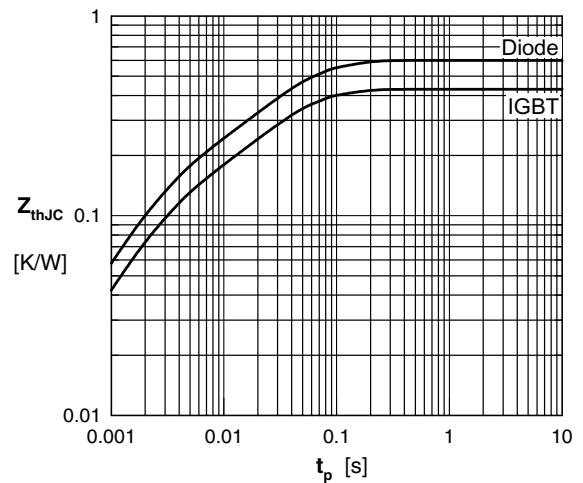

Fig. 9 Typ. transient thermal impedance