

# IGBT

**IXGH 35N120C**  
**IXGT 35N120C**

## Lightspeed Series

**$V_{CES} = 1200\text{ V}$**   
 **$I_{C25} = 70\text{ A}$**   
 **$V_{CE(sat)} = 4.0\text{ V}$**   
 **$t_{fi(typ)} = 115\text{ ns}$**

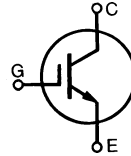

Symbol	Test Conditions	Maximum Ratings
$V_{CES}$	$T_J = 25^\circ\text{C to } 150^\circ\text{C}$	1200 V
$V_{CGR}$	$T_J = 25^\circ\text{C to } 150^\circ\text{C}; R_{GE} = 1\text{ M}\Omega$	1200 V
$V_{GES}$	Continuous	$\pm 20\text{ V}$
$V_{GEM}$	Transient	$\pm 30\text{ V}$
$I_{C25}$	$T_C = 25^\circ\text{C}$	70 A
$I_{C90}$	$T_C = 90^\circ\text{C}$	35 A
$I_{CM}$	$T_C = 25^\circ\text{C}, 1\text{ ms}$	140 A
<b>SSOA (RBSOA)</b>	$V_{GE} = 15\text{ V}, T_{VJ} = 125^\circ\text{C}, R_G = 5\ \Omega$ Clamped inductive load	$I_{CM} = 90$ @ $0.8 V_{CES}$
$P_C$	$T_C = 25^\circ\text{C}$	300 W
$T_J$		-55 ... +150 $^\circ\text{C}$
$T_{JM}$		150 $^\circ\text{C}$
$T_{stg}$		-55 ... +150 $^\circ\text{C}$
Maximum Lead temperature for soldering 1.6 mm (0.062 in.) from case for 10 s		300 $^\circ\text{C}$
Maximum Tab temperature for soldering SMD devices for 10 s		260 $^\circ\text{C}$
$M_d$	Mounting torque (M3)	1.13/10 Nm/lb.in.
<b>Weight</b>	TO-247 AD	6 g
	TO-268	4 g

**TO-268 (IXGT)**

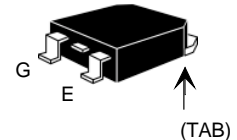

**TO-247 AD (IXGH)**

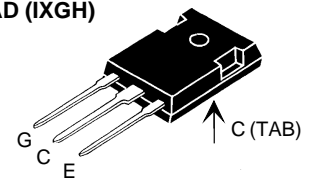

G = Gate,  
E = Emitter,

C = Collector,  
TAB = Collector

### Features

- International standard packages  
JEDEC TO-268 surface and  
JEDEC TO-247 AD
- Low switching losses
- MOS Gate turn-on  
- drive simplicity

### Applications

- AC motor speed control
- DC servo and robot drives
- DC choppers
- Uninterruptible power supplies (UPS)
- Switched-mode and resonant-mode  
power supplies

### Advantages

- High power density
- Suitable for surface mounting
- Easy to mount with 1 screw,  
(isolated mounting screw hole)

Symbol	Test Conditions	Characteristic Values ( $T_J = 25^\circ\text{C}$ , unless otherwise specified)		
		min.	typ.	max.
$BV_{CES}$	$I_C = 1\text{ mA}, V_{GE} = 0\text{ V}$	1200		V
$V_{GE(th)}$	$I_C = 750\ \mu\text{A}, V_{CE} = V_{GE}$	2.5		V
$I_{CES}$	$V_{CE} = V_{CES}$ $V_{GE} = 0\text{ V}$	$T_J = 25^\circ\text{C}$		250 $\mu\text{A}$
		$T_J = 125^\circ\text{C}$		5 mA
$I_{GES}$	$V_{CE} = 0\text{ V}, V_{GE} = \pm 20\text{ V}$			$\pm 100\text{ nA}$
$V_{CE(sat)}$	$I_C = I_{C90}, V_{GE} = 15\text{ V}$	$T_J = 125^\circ\text{C}$		4.0 V
			3.2	V

Symbol	Test Conditions	Characteristic Values ( $T_J = 25^\circ\text{C}$ , unless otherwise specified)			
		min.	typ.	max.	
$g_{fs}$	$I_C = I_{C90}; V_{CE} = 10\text{ V}$ , Pulse test, $t \leq 300\ \mu\text{s}$ , duty cycle $\leq 2\%$	30	40	S	
$C_{ies}$	$V_{CE} = 25\text{ V}$ , $V_{GE} = 0\text{ V}$ , $f = 1\text{ MHz}$		4620	pF	
$C_{oes}$			260	pF	
$C_{res}$			90	pF	
$Q_g$	$I_C = I_{C90}$ , $V_{GE} = 15\text{ V}$ , $V_{CE} = 0.5 V_{CES}$		170	nC	
$Q_{ge}$			28	nC	
$Q_{gc}$			57	nC	
$t_{d(on)}$	<b>Inductive load, <math>T_J = 25^\circ\text{C}</math></b> $I_C = I_{C90}$ , $V_{GE} = 15\text{ V}$ $V_{CE} = 0.8 V_{CES}$ , $R_G = R_{off} = 5\ \Omega$ Remarks: Switching times may increase for $V_{CE}$ (Clamp) $> 0.8 \cdot V_{CES}$ , higher $T_J$ or increased $R_G$		50	ns	
$t_{ri}$			27	ns	
$t_{d(off)}$			150	220	ns
$t_{fi}$			115	190	ns
$E_{off}$			3.0	4.2	mJ
$t_{d(on)}$	<b>Inductive load, <math>T_J = 125^\circ\text{C}</math></b> $I_C = I_{C90}$ , $V_{GE} = 15\text{ V}$ $V_{CE} = 0.8 V_{CES}$ , $R_G = R_{off} = 5\ \Omega$ Remarks: Switching times may increase for $V_{CE}$ (Clamp) $> 0.8 \cdot V_{CES}$ , higher $T_J$ or increased $R_G$		55	ns	
$t_{ri}$			31	ns	
$E_{on}$			2.6	mJ	
$t_{d(off)}$			220	ns	
$t_{fi}$			260	ns	
$E_{off}$		6.2	mJ		
$R_{thJC}$				0.42 K/W	
$R_{thCK}$	(TO-247)	0.25		K/W	

### TO-247 AD (IXGH) Outline

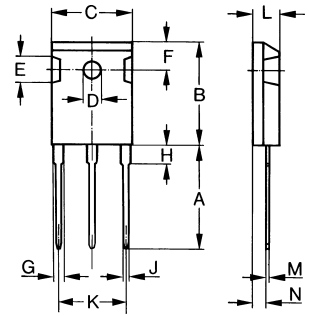

Dim.	Millimeter		Inches	
	Min.	Max.	Min.	Max.
A	19.81	20.32	0.780	0.800
B	20.80	21.46	0.819	0.845
C	15.75	16.26	0.610	0.640
D	3.55	3.65	0.140	0.144
E	4.32	5.49	0.170	0.216
F	5.4	6.2	0.212	0.244
G	1.65	2.13	0.065	0.084
H	-	4.5	-	0.177
J	1.0	1.4	0.040	0.055
K	10.8	11.0	0.426	0.433
L	4.7	5.3	0.185	0.209
M	0.4	0.8	0.016	0.031
N	1.5	2.49	0.087	0.102

### TO-268AA (D<sup>3</sup> PAK)

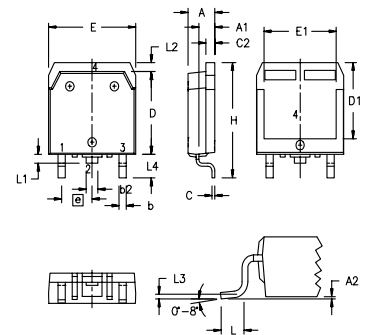

Dim.	Millimeter		Inches	
	Min.	Max.	Min.	Max.
A	4.9	5.1	.193	.201
A <sub>1</sub>	2.7	2.9	.106	.114
A <sub>2</sub>	.02	.25	.001	.010
b	1.15	1.45	.045	.057
b <sub>2</sub>	1.9	2.1	.75	.83
C	.4	.65	.016	.026
D	13.80	14.00	.543	.551
E	15.85	16.05	.624	.632
E <sub>1</sub>	13.3	13.6	.524	.535
e	5.45 BSC		.215 BSC	
H	18.70	19.10	.736	.752
L	2.40	2.70	.094	.106
L <sub>1</sub>	1.20	1.40	.047	.055
L <sub>2</sub>	1.00	1.15	.039	.045
L <sub>3</sub>	0.25 BSC		.010 BSC	
L <sub>4</sub>	3.80	4.10	.150	.161

