

NEW

Radiometrix

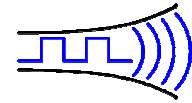

Hartcran House, 231 Kenton Lane, Harrow, HA3 8RP, England
Tel: +44 (0) 20 8909 9595, Fax: +44 (0) 20 8909 2233

Issue 1, April 2007

NRX1

Low cost VHF Narrow Band FM receiver

The NRX1 is a VHF radio data receiver and it offers a low power, reliable data link in a Radiometrix SIL standard pin out and footprint.

It is an enhanced, low cost version of the Radiometrix RX1, but in a slightly larger dimension.

NRX1 is compatible with the TX1 series of transmitters, and the BiM1 transceiver.



Figure 1: NRX1-173.225-10

Features

- Designed to comply with harmonised radio standard EN 300 220-3 and EMC standard EN 301 489-3
- Frequencies available as standard: 151.3000MHz, 169.4125MHz, 173.2250MHz and 173.2500MHz
- Other custom frequencies from 120MHz to 180MHz available to order
- Data rates up to 10 kbps with 25kHz channel spacing
- Usable range to 10km+ with matching transmitter
- Fully screened

NRX1 is a VHF equivalent of Radiometrix UHF NRX2 receiver and it is available for licence-exempt operation in the UK 173MHz bands and European 169MHz band. It is also available in the Australian frequency of 151.300MHz. NRX1 modules combine effective screening with internal filtering to minimise spurious radiation and susceptibility thereby ensuring EMC compliance. They are particularly suitable for one-to-one and multi-node wireless links where longer ranges are required at low to moderate data rates. Applications include building security, EPOS and inventory tracking, remote industrial process monitoring and data networks. Because of their small size and low power consumption, these modules are ideal for use in battery-powered portable applications such as handheld terminals.

Technical Summary

- Double conversion FM superhet
- Supply range: 2.9V - 15V @ 10mA (internal 2.8V voltage regulator)
- Data bit rate: 10kbps max.
- Receiver sensitivity: -120dBm (for 12dB SINAD)
- Local Oscillator (LO) re-radiation: <-60dBm
- Adjacent Channel: -70dBm
- Blocking: -86dB

NRX1

Single channel VHF receiver

$$F_{xtal} (RX) = (F_{chan} - 21.4MHz) \times 0.5$$

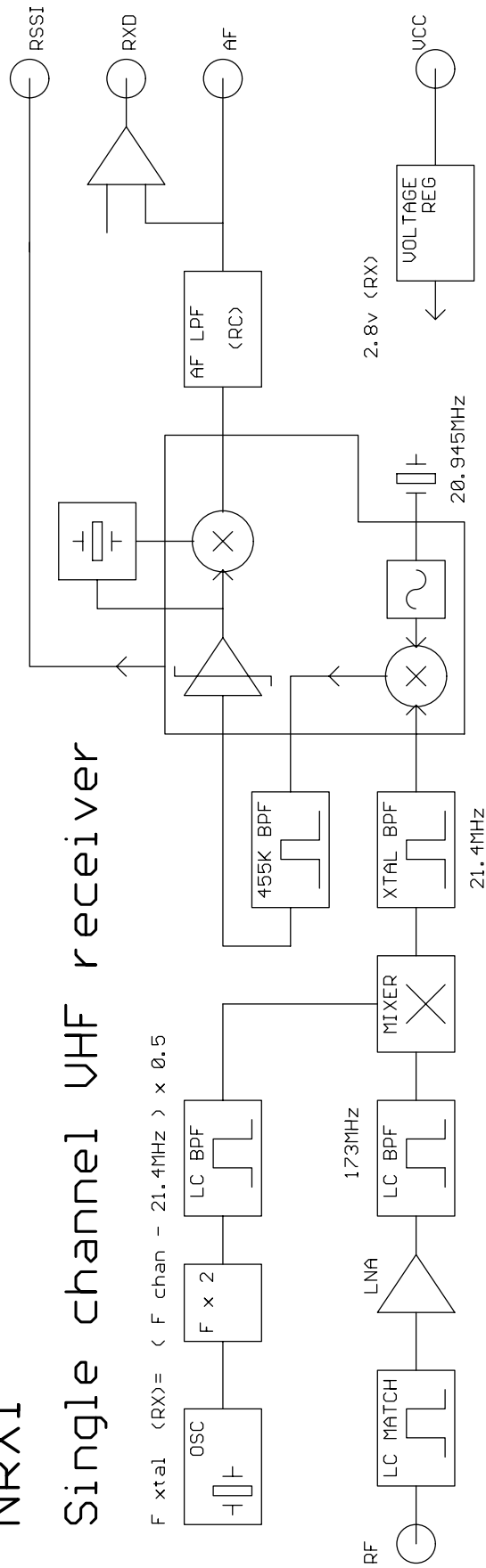

Figure 2: NRX1 block diagram

User interface

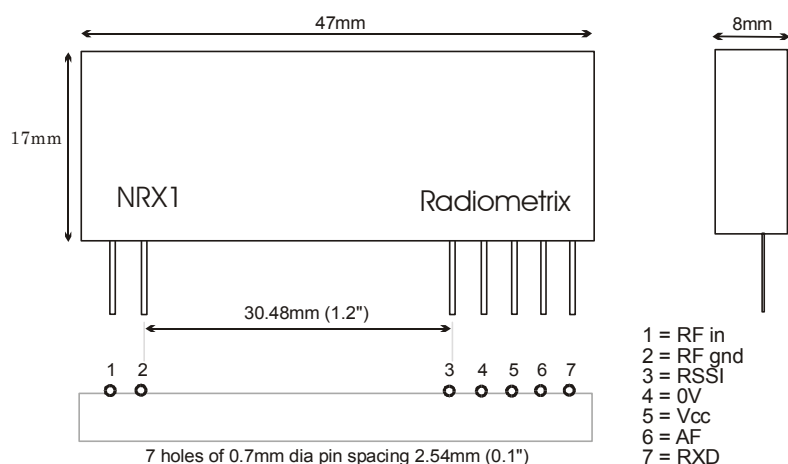

Figure 3: NRX1 pin-out and dimension

NRX1 pin	Name	Function
1	RF in	50Ω RF output to the antenna
2	RF gnd	RF ground
3	RSSI	DC level between 0.5V and 2V; 60dB dynamic range
4	0V	Ground
5	Vcc	5V regulated DC power supply
6	AF	500mVp-p audio. DC coupled, approx 0.8V bias
7	RXD	.5Vp-p logic output of data slicer. Suitable for Biphase codes

Note: Pinout and footprint as RX1 (but larger dimension and lacks Enable pin) and UHF NRX2.

Condensed specifications

Frequency	151.3000MHz 169.4125MHz 173.2250MHz 173.2500MHz (other VHF 120-180MHz by special order)
<i>Frequency stability</i>	±2.5kHz
<i>Channel spacing</i>	25kHz
<i>Number of channels</i>	1
Supply <i>voltage</i>	2.9 – 15V
<i>Current</i>	10mA
Operating temperature	-10 to +60 °C (Storage -30 to +70 °C)
Size	47 x 17 x 8 mm
Spurious radiations	Compliant with ETSI EN 300 220-3 and EN 301 489-3
Interface <i>User</i>	5 pin 0.1" pitch SIL
<i>RF</i>	2 pin 0.1" pitch SIL
Receiver	
Sensitivity	-120dBm for 12dB SINAD
image / spurious	-60dB (or better)
blocking	-86dB (or better)
adjacent channel	-70dB
LO re-radiation	<-65dBm
Outputs	RSSI, Audio, Data
Power on to valid audio	2ms
Power on to stable data out	10ms (for 50:50 mark / space)

Applications information

RX Received Signal Strength Indicator (RSSI)

The NRX1 has a wide range RSSI which measures the strength of an incoming signal over a range of 60dB or more. This allows assessment of link quality and available margin and is useful when performing range tests.

The output on pin 11 of the module has a standing DC bias of up to 0.5V with no signal, rising to 2.4V at maximum indication. $\Delta V_{\text{min-max}}$ is typically 1V and is largely independent of standing bias variations. Output impedance is 56k Ω . Pin 11 can drive a 100 μ A meter directly, for simple monitoring.

Typical RSSI characteristic is as shown below:

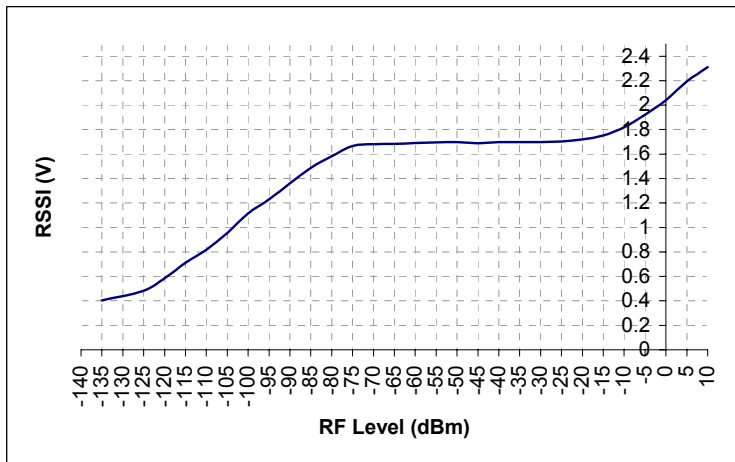

Figure 4: RSSI level with respect to received RF level at NRX1 antenna pin

Packet data

In general, data to be sent via a radio link is formed into a serial "packet" of the form :-

Preamble - Control - Address - Data - CRC

Where: **Preamble:** This is mandatory for the adaptive data slicer in the receiver in the NRX1 to stabilise. The NRX1 will be stable after 10ms. Additional preamble time may be desired for decoder bit synchronisation, firmware carrier detection or receiver wake up.

Control: The minimum requirement is a single bit or unique bit pattern to indicate the start of message (frame sync.). Additionally, decoder information is often placed here such as: packet count, byte count, flow control bits (e.g. ACK, repeat count), repeater control, scrambler information etc.

Address: This information is used for identification purposes and would at least contain a 16/24 bit source address, additionally - destination address, site / system code, unit number and repeater address's may be placed here.

Data: User data, generally limited to 256 bytes or less (very long packets should be avoided to minimise repeat overheads on CRC failure and channel hogging).

CRC: 16/24 Bit CRC or Checksum of control-address-data fields used by the decoder to verify the integrity of the packet.

The exact makeup of the packet depends upon the system requirements and may involve some complex air-traffic density statistics to optimise through-put in large networked systems.

Antennas

The choice and positioning of transmitter and receiver antennas is of the utmost importance and is the single most significant factor in determining system range. The following notes are intended to assist the user in choosing the most effective antenna type for any given application.

Integral antennas

These are relatively inefficient compared to the larger externally-mounted types and hence tend to be effective only over limited ranges. They do however result in physically compact equipment and for this reason are often preferred for portable applications. Particular care is required with this type of antenna to achieve optimum results and the following should be taken into account:

1. Nearby conducting objects such as a PCB or battery can cause detuning or screening of the antenna which severely reduces efficiency. Ideally the antenna should stick out from the top of the product and be entirely in the clear, however this is often not desirable for practical/ergonomic reasons and a compromise may need to be reached. If an internal antenna must be used try to keep it away from other metal components and pay particular attention to the “hot” end (i.e. the far end) as this is generally the most susceptible to detuning. The space around the antenna is as important as the antenna itself.
2. Microprocessors and microcontrollers tend to radiate significant amounts of radio frequency hash which can cause desensitisation of the receiver if its antenna is in close proximity. The problem becomes worse as logic speeds increase, because fast logic edges generate harmonics across the VHF range which are then radiated effectively by the PCB tracking. In extreme cases system range may be reduced by a factor of 5 or more. To minimise any adverse effects situate antenna and module as far as possible from any such circuitry and keep PCB track lengths to the minimum possible. A ground plane can be highly effective in cutting radiated interference and its use is strongly recommended.

A simple test for interference is to monitor the receiver RSSI output voltage, which should be the same regardless of whether the microcontroller or other logic circuitry is running or in reset.

The following types of integral antenna are in common use:

Quarter-wave whip. This consists simply of a piece of wire or rod connected to the module at one end. At 173MHz the total length should be 410mm from module pin to antenna tip including any interconnecting wire or tracking. Because of the length of this antenna it is almost always external to the product casing.

Helical. This is a more compact but slightly less effective antenna formed from a coil of wire. It is very efficient for its size, but because of its high Q it suffers badly from detuning caused by proximity to nearby conductive objects and needs to be carefully trimmed for best performance in a given situation. The size shown is about the maximum commonly used at 173MHz and appropriate scaling of length, diameter and number of turns can make individual designs much smaller.

Loop. A loop of PCB track having an inside area as large as possible (minimum about 5cm²), tuned and matched with 2 capacitors. Loops are relatively inefficient but have good immunity to proximity detuning, so may be preferred in shorter range applications where high component packing density is necessary.

Integral antenna summary:

	whip	helical	loop
Ultimate performance	***	**	*
Ease of design set-up	***	**	*
Size	*	***	**
Immunity to proximity effects	**	*	***

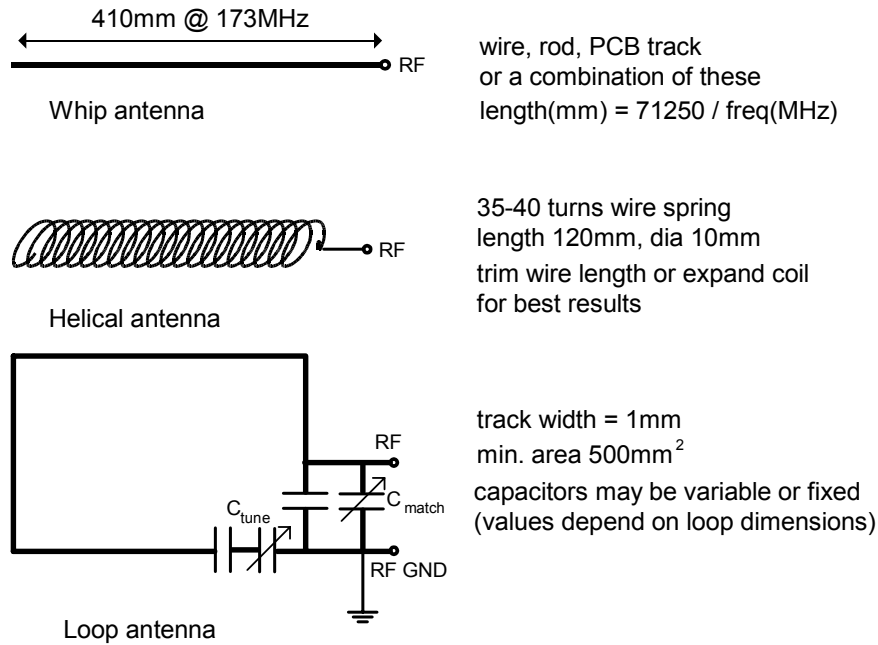

Figure 5: integral antenna configurations

External antennas

These have several advantages if portability is not an issue, and are essential for long range links. External antennas can be optimised for individual circumstances and may be mounted in relatively good RF locations away from sources of interference, being connected to the equipment by coax feeder.

Helical. Of similar dimensions and performance to the integral type mentioned above, commercially-available helical antennas normally have the coil element protected by a plastic moulding or sleeve and incorporate a coax connector at one end (usually a straight or right-angle BNC type). These are compact and simple to use as they come pre-tuned for a given application, but are relatively inefficient and are best suited to shorter ranges.

Quarter-wave whip. Again similar to the integral type, the element usually consists of a stainless steel rod or a wire contained within a semi-flexible moulded plastic jacket. Various mounting options are available, from a simple BNC connector to wall brackets, through-panel fixings and magnetic mounts for temporary attachment to steel surfaces.

Ground plane

A significant improvement in performance is obtainable if the whip is used in conjunction with a metal ground plane. For best results this should extend all round the base of the whip out to a radius of 300mm or more (under these conditions performance approaches that of a half-wave dipole) but even relatively small metal areas will produce a worthwhile improvement over the whip alone. The ground plane should be electrically connected to the coax outer at the base of the whip. Magnetic mounts are slightly different in that they rely on capacitance between the mount and the metal surface to achieve the same result.

As shown on figure 9, a ground plane can also be simulated by using 3 or 4 quarter-wave radials equally spaced around the base of the whip, connected at their inner ends to the outer of the coax feed. A better match to a 50Ω coax feed can be achieved if the elements are angled downwards at approximately 30-40° to the horizontal.

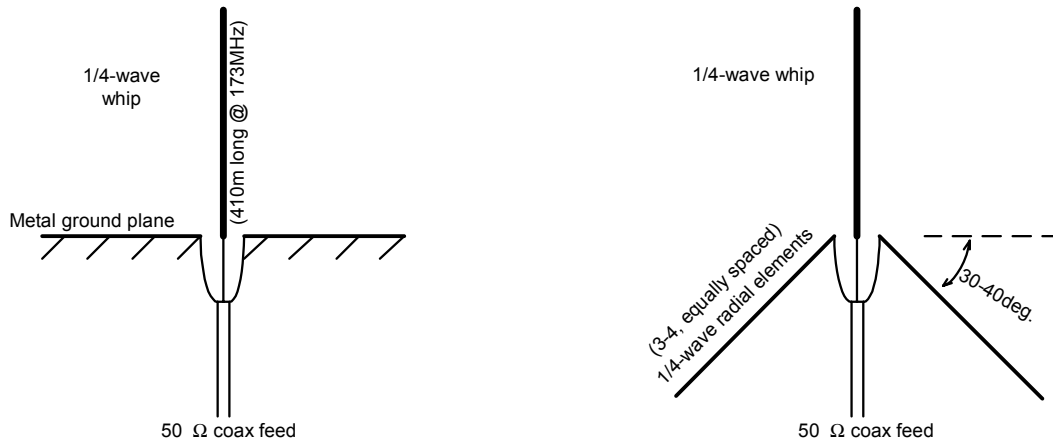

Figure 6: Quarter wave antenna / ground plane configurations

Half-wave. There are two main variants of this antenna, both of which are very effective and are recommended where long range and all-round coverage are required:

1. The half-wave dipole consists of two quarter-wave whips mounted in line vertically and fed in the centre with coaxial cable. The bottom whip takes the place of the ground plane described previously. A variant is available using a helical instead of a whip for the lower element, giving similar performance with reduced overall length. This antenna is suitable for mounting on walls etc. but for best results should be kept well clear of surrounding conductive objects and structures (ideally >1m separation).
2. The end-fed half wave is the same length as the dipole but consists of a single rod or whip fed at the bottom via a matching network. Mounting options are similar to those for the quarter-wave whip. A ground plane is sometimes used but is not essential. The end-fed arrangement is often preferred over the centre-fed dipole because it is easier to mount in the clear and above surrounding obstructions.

Yagi. This antenna consists of two or more elements mounted parallel to each other on a central boom. It is directional and exhibits gain but tends to be large and unwieldy – for these reasons the yagi is the ideal choice for links over fixed paths where maximum range is desired.

For best range in UK fixed link applications use a half-wave antenna on the matching transmitter (e.g. TX1, BiM1T) and a half-wave or Yagi on NRX1 receiver, both mounted as high as possible and clear of obstructions.

Module mounting considerations

Good RF layout practice should be observed. If the connection between module and antenna is more than about 20mm long use 50Ω microstrip line or coax or a combination of both. It is desirable (but not essential) to fill all unused PCB area around the module with ground plane.

Variants and ordering information

The NRX1 receiver is manufactured in the following variants as standard:

NRX1-151.300-10	(151.300MHz Australian licence exempt frequency)
NRX1-169.4125-10	(169.4125 European licence exempt frequency -169MHz band)
NRX1-173.225-10	(for UK alarm applications on 173.225MHz)
NRX1-173.250-10	(for UK general applications on 173.250MHz)

Matching transmitter: **TX1-xxx.xxx-10** (where xxx.xxx is the operating frequency)

Radiometrix Ltd

Harteran House

231 Kenton Lane

Harrow, Middlesex

HA3 8RP

ENGLAND

Tel: +44 (0) 20 8909 9595

Fax: +44 (0) 20 8909 2233

sales@radiometrix.com

www.radiometrix.com

Copyright notice

This product data sheet is the original work and copyrighted property of Radiometrix Ltd. Reproduction in whole or in part must give clear acknowledgement to the copyright owner.

Limitation of liability

The information furnished by Radiometrix Ltd is believed to be accurate and reliable. Radiometrix Ltd reserves the right to make changes or improvements in the design, specification or manufacture of its subassembly products without notice. Radiometrix Ltd does not assume any liability arising from the application or use of any product or circuit described herein, nor for any infringements of patents or other rights of third parties which may result from the use of its products. This data sheet neither states nor implies warranty of any kind, including fitness for any particular application. These radio devices may be subject to radio interference and may not function as intended if interference is present. We do NOT recommend their use for life critical applications.

The Intrastat commodity code for all our modules is: 8542 6000

R&TTE Directive

After 7 April 2001 the manufacturer can only place finished product on the market under the provisions of the R&TTE Directive. Equipment within the scope of the R&TTE Directive may demonstrate compliance to the essential requirements specified in Article 3 of the Directive, as appropriate to the particular equipment.

Further details are available on The Office of Communications (Ofcom) web site:

<http://www.ofcom.org.uk/radiocomms/ifi/>

Information Requests

Ofcom

Riverside House

2a Southwark Bridge Road

London SE1 9HA

Tel: +44 (0)845 456 3000 or 020 7981 3040

Fax: +44 (0)20 7783 4033

information.requests@ofcom.org.uk

European Radiocommunications Office (ERO)

Peblingehus

Nansensgade 19

DK 1366 Copenhagen

Tel. +45 33896300

Fax +45 33896330

ero@ero.dk

www.ero.dk