

SMD Tactile Switch

B3FS-4

Surface-mounting Switches with 12 x 12 mm size

- Surface-mounting device of B3F-4 series.
- Distinctive snapping action and extended mechanical/electrical durability.
- Available in embossed tapping packages for automatic mounting.

RoHS Compliant



NEW

Ordering Information

List of Models

Type	Plunger type	Height	Operating force (OF)	Plunger color	Embossed taping	
					Model	Quantity per package
12 x 12 mm B3FS-4002P		4.3 mm	1.47 N	Black	B3FS-4002P	1,000

Note: Order in multiples of the minimum order unit. Switches are not sold individually.

Specifications

Ratings/Characteristics

Switching capacity	1 to 50 mA, 5 to 24 VDC (resistive load)
Ambient operating temperature	-25 to +70 degC at 60%RH max. (with no icing or condensation)
Ambient operating humidity	35 to 85%RH (at +5 to +35 degC)
Contact configuration	SPST-NO
Contact resistance	100 mΩ max. (initial value) (rated: 1 mA, 5 VDC)
Insulation resistance	100 MΩ (at 250 VDC)
Dielectric strength	500 VAC 50/60Hz for 1min
Vibration resistance	Malfunction: 10 to 55 Hz, 1.5-mm double amplitude
Shock resistance	Destruction: 1,000 m/s ² (approx. 100 G) max. Malfunction: 100 m/s ² (approx. 10 G) max.
Durability	3,000,000 operations min.
Weight	Approx. 1 g

Operating Characteristics

Item	Model	B3FS-4002P
Operating force (OF)		1.47±0.49N {150±50 gf}
Releasing force (RF)		0.15 N {15 gf} min.
Pretravel (PT)		0.25±0.15 mm

Dimensions

Note: 1. All units are in millimeters unless otherwise indicated. Unless otherwise specified, a tolerance of ±0.4 mm applies to all dimensions.

Note: 2. The numbers used for terminals in the following graphics are indicated in the "Bottom View" diagram in the right. In this diagram, the Switch is rotated so that the terminals are on the right and left-hand sides, and the OMRON logo appears the right way up.



B3FS-4002P

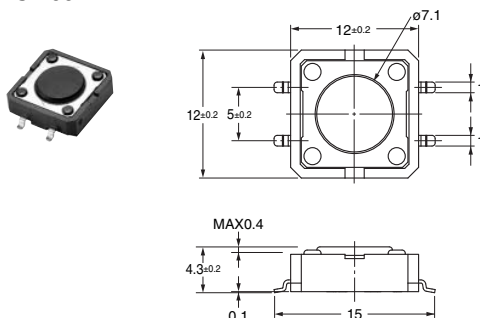

PCB Pad (Example) (TOP VIEW)

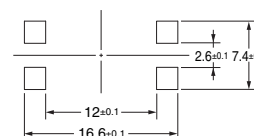

Terminal Arrangement/ Internal Connection (Top View)

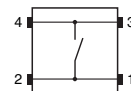

■ Precautions

Be sure to read the safety precautions common to all Tactile Switches for correct use.

Precautions for Correct Use

● PCBs

If the PCBs are separated after mounting the Switch, particles from the PCBs may enter the Switch. If PCB particles or foreign particles from the surrounding environment, workbench, containers, or stacked PCBs become attached to the Switch, contact failure may result.

● Soldering

1. General Precautions

Before soldering the Switch on a multilayer PCB, test to confirm that soldering can be performed properly. Otherwise the Switch may be deformed by the soldering heat on the pattern or lands of the multilayer PCB.

Do not solder the Switch more than twice, including rectification soldering. An interval of five minutes is required between the first and the second soldering, or it may result in melting housing and deterioration of operating characteristics.

2. Reflow Soldering (Surface Mounting)

Solder the terminals within the heating curve shown in the following diagram.

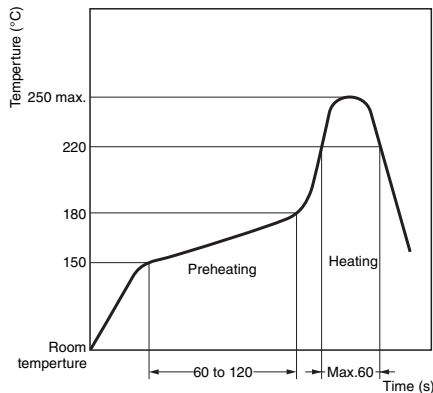

Note: The above heating curve applies if the PCB thickness is 1.6 mm.

The peak temperature may vary depending on the reflow bath used. Confirm the conditions beforehand.

Do not use an automatic soldering bath for surface-mounted Switches. The soldering gas or flux may enter the Switch and damage the Switch's plunger operation.

3. Manual Soldering

Soldering temperature: 350 degC max. at the tip of the soldering iron
Soldering time: 3 s max. for a 1.6-mm thick, single-side PCB
Before soldering the Switch on a PCB, make sure that there is no unnecessary space between the Switch and the PCB.

● Washing

This switch cannot be washed.

Doing so will cause the washing agent, together with flux or dust particles on the PCB, to enter the Switch, resulting in malfunction.

● Packaging Specifications for Embossed Taping

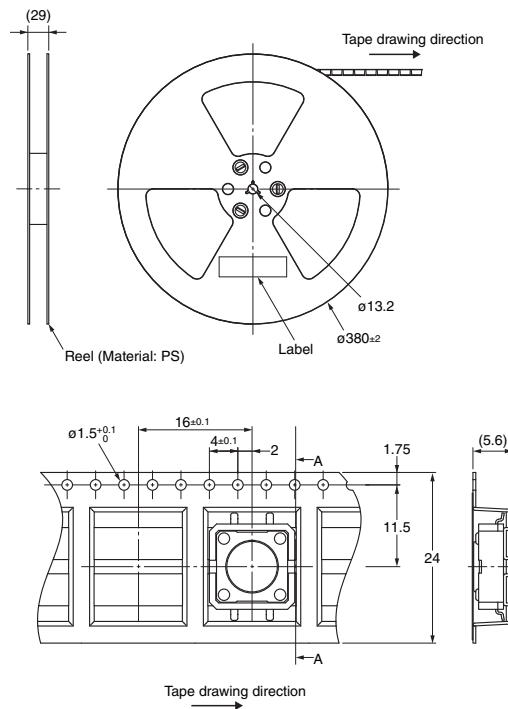

● RoHS Compliant

The "RoHS Compliant" designation indicates that the listed models do not contain the six hazardous substances covered by the RoHS Directive.

Reference:

The following standards are used to determine compliance for the six substances.

Lead: 1,000 ppm max.

Mercury: 1,000 ppm max.

Cadmium: 100 ppm max.

Hexavalent chromium: 1,000 ppm max.

PBB: 1,000 ppm max.

PBDE: 1,000 ppm max.

ALL DIMENSIONS SHOWN ARE IN MILLIMETERS.

To convert millimeters into inches, multiply by 0.03937. To convert grams into ounces, multiply by 0.03527.