

ATV32HU75N4

variable speed drive ATV32 - 7.5 kw - 400 V - 3 phase - with heat sink



Main

Range of product	Altivar 32
Product or component type	Variable speed drive
Product specific application	Complex machines
Assembly style	With heat sink
Component name	ATV32
EMC filter	Class C2 EMC filter integrated
Network number of phases	3 phases
[Us] rated supply voltage	380...500 V (- 15...10 %)
Motor power kW	7.5 kW at 380...500 V 3 phases
Motor power hp	10 hp at 380...500 V 3 phases
Line current	18.7 A for 500 V 3 phases 7.5 kW / 10 hp 26.5 A for 380 V 3 phases 7.5 kW / 10 hp
Apparent power	22.9 kVA at 500 V 3 phases 7.5 kW / 15 hp
Prospective line I _{sc}	<= 22 kA, 3 phases
Nominal output current	17 A at 4 kHz 500 V 3 phases 7.5 kW / 10 hp
Maximum transient current	25.5 A for 60 s 3 phases 7.5 kW / 10 hp
Speed drive output frequency	0.5...599 Hz
Nominal switching frequency	4 kHz
Switching frequency	2...16 kHz adjustable
Asynchronous motor control profile	Voltage/Frequency ratio, 2 points Voltage/Frequency ratio, 5 points Flux vector control without sensor - Energy Saving, NoLoad law Flux vector control without sensor, standard Voltage/Frequency ratio - Energy Saving, quadratic U/f
Type of polarization	No impedance for Modbus

Complementary

Product destination	Asynchronous motors Synchronous motors
Supply voltage limits	323...550 V
Supply frequency	50...60 Hz (- 5...5 %)
Network frequency limits	47.5...63 Hz
Speed range	1...100 for asynchronous motor in open-loop mode
Speed accuracy	+/- 10 % of nominal slip for 0.2 T _n to T _n torque variation
Torque accuracy	+/- 15 %
Transient overtorque	3 % of nominal motor torque
Braking torque	< 170 % with braking resistor
Synchronous motor control profile	Vector control without sensor
Regulation loop	Adjustable PID regulator
Motor slip compensation	Automatic whatever the load Not available in voltage/frequency ratio (2 or 5 points) Adjustable 0...300 %

The information provided in this documentation contains general descriptions and/or technical characteristics of the performance of the products contained herein. This documentation is not intended as a substitute for and is not to be used for determining suitability or reliability of these products for specific user applications. It is the duty of any such user or integrator to perform the appropriate and complete risk analysis, evaluation and testing of the products with respect to the relevant specific application or use thereof. Neither Schneider Electric Industries SAS nor any of its affiliates or subsidiaries shall be responsible or liable for misuse of the information contained herein.

Local signalling	1 LED red presence of drive voltage 1 LED blue presence of bluetooth 1 LED green presence of CANopen run 1 LED red presence of CANopen error 1 LED red presence of drive fault
Output voltage	<= power supply voltage
Insulation	Electrical between power and control
Electrical connection	Control screw terminal 0.5...1.5 mm ² / AWG18...AWG14 Motor/Braking resistor removable screw terminals 2.5...16 mm ² / AWG12...AWG6 Power supply screw terminal 6...16 mm ² / AWG8...AWG6
Tightening torque	Control 0.5 N.m / 4.4 lb/ft Motor/Braking resistor 1.2 N.m / 10.6 lb/ft Power supply 1.2 N.m / 10.6 lb/ft
Supply	Internal supply for reference potentiometer (1 to 10 kOhm), 10.5 V DC +/- 5 % , <= 10 mA for overload and short-circuit protection
Analogue input number	3
Analogue input type	AI1 voltage 0...10 V DC , impedance 30000 Ohm, resolution 10 bits AI2 bipolar differential voltage +/- 10 V DC , impedance 30000 Ohm, resolution 10 bits AI3 current 0...20 mA (or 4-20 mA, x-20 mA, 20-x mA or other patterns by configuration) , impedance 250 Ohm, resolution 10 bits
Sampling duration	AI1, AI2, AI3 2 ms for analog input(s) AO1 2 ms for analog input(s)
Response time	LI1...LI6 8 ms, tolerance +/- 0.7 ms for logic output(s) R1A, R1B, R1C 2 ms for relay output(s) R2A, R2C 2 ms for relay output(s)
Accuracy	AI1, AI2, AI3 +/- 0.2 % for a temperature of -10...60 °C AI1, AI2, AI3 +/- 0.5 % for a temperature of 25 °C AO1 +/- 1 % for a temperature of 25 °C AO1 +/- 2 % for a temperature of -10...60 °C
Linearity error	AI1, AI2, AI3 +/- 0.2...0.5 % of maximum value AO1 +/- 0.3 %
Analogue output number	1
Analogue output type	AO1 software-configurable current 0...20 mA , impedance 800 Ohm, resolution 10 bits AO1 software-configurable voltage 0...10 V , impedance 470 Ohm, resolution 10 bits
Discrete output number	3
Discrete output type	R1A, R1B, R1C configurable relay logic NO/NC, electrical durability 100000 cycles R2A, R2B configurable relay logic NO, electrical durability 100000 cycles LO logic
Minimum switching current	Configurable relay logic 5 mA at 24 V DC
Maximum switching current	R1 on resistive load, 3 A at 250 V AC, R1 on resistive load, 4 A at 30 V DC, R1, R2 on inductive load, 2 A at 250 V AC, R1, R2 on inductive load, 2 A at 30 V DC, R2 on resistive load, 5 A at 250 V AC, R2 on resistive load, 5 A at 30 V DC,
Discrete input number	7
Discrete input type	LI1...LI4 programmable (sink/source) 24...30 V DC , with level 1 PLC LI5 programmable as pulse input 20 kpps 24...30 V DC , with level 1 PLC LI6 switch-configurable PTC probe 24...30 V DC STO safe torque off 24...30 V DC , impedance 1500 Ohm
Discrete input logic	LI1...LI6 negative logic (sink), > 19 V (state 0), < 13 V (state 0) LI1...LI6 positive logic (source), < 5 V (state 0), > 11 V (state 0)
Acceleration and deceleration ramps	S U CUS Deceleration ramp automatic stop DC injection Deceleration ramp adaptation Linear Ramp switching
Braking to standstill	By DC injection
Protection type	Input phase breaks drive Overcurrent between output phases and earth drive Overheating protection drive Short-circuit between motor phases drive Thermal protection drive

Communication port protocol	CANopen Modbus
Type of connector	1 RJ45 for Modbus/CANopen on front face
Physical interface	2-wire RS 485 for Modbus
Transmission frame	RTU for Modbus
Number of addresses	1...127 for CANopen 1...247 for Modbus
Method of access	Slave for CANopen
Marking	CE
Operating position	Vertical +/- 10 degree
Width	150 mm
Height	308 mm
Depth	232 mm
Product weight	7.5 kg
Option card	Communication card CANopen daisy chain Communication card CANopen open style Communication card DeviceNet Communication card Ethernet/IP Communication card Profibus DP V1

Environment

Noise level	43 dB conforming to 86/188/EEC
Electromagnetic compatibility	1.2/50 μ s - 8/20 μ s surge immunity test conforming to IEC 61000-4-5 level 3 Conducted radio-frequency immunity test conforming to IEC 61000-4-6 level 3 Electrical fast transient/burst immunity test conforming to IEC 61000-4-4 level 4 Electrostatic discharge immunity test conforming to IEC 61000-4-2 level 3 Radiated radio-frequency electromagnetic field immunity test conforming to IEC 61000-4-3 level 3 Voltage dips and interruptions immunity test conforming to IEC 61000-4-11
Standards	EN 55011 class A group 1 EN 61800-3 environments 1 category C2 EN 61800-3 environments 2 category C2 EN/IEC 61800-3 EN/IEC 61800-5-1
Product certifications	CSA C-Tick GOST NOM 117 UL
Pollution degree	2 conforming to EN/IEC 61800-5-1
IP degree of protection	IP20 conforming to EN/IEC 61800-5-1
Vibration resistance	1 gn (f = 13...200 Hz) conforming to EN/IEC 60068-2-6 1.5 mm peak to peak (f = 3...13 Hz) conforming to EN/IEC 60068-2-6
Shock resistance	15 gn for 11 ms conforming to EN/IEC 60068-2-27
Relative humidity	5...95 % without condensation conforming to IEC 60068-2-3 5...95 % without dripping water conforming to IEC 60068-2-3
Ambient air temperature for operation	-10...50 °C without derating 50...60 °C with derating factor
Ambient air temperature for storage	-25...70 °C
Operating altitude	<= 1000 m without derating 1000...3000 m with current derating 1 % per 100 m
RoHS EUR status	Compliant
RoHS EUR conformity date	1012

Size C

Dimensions

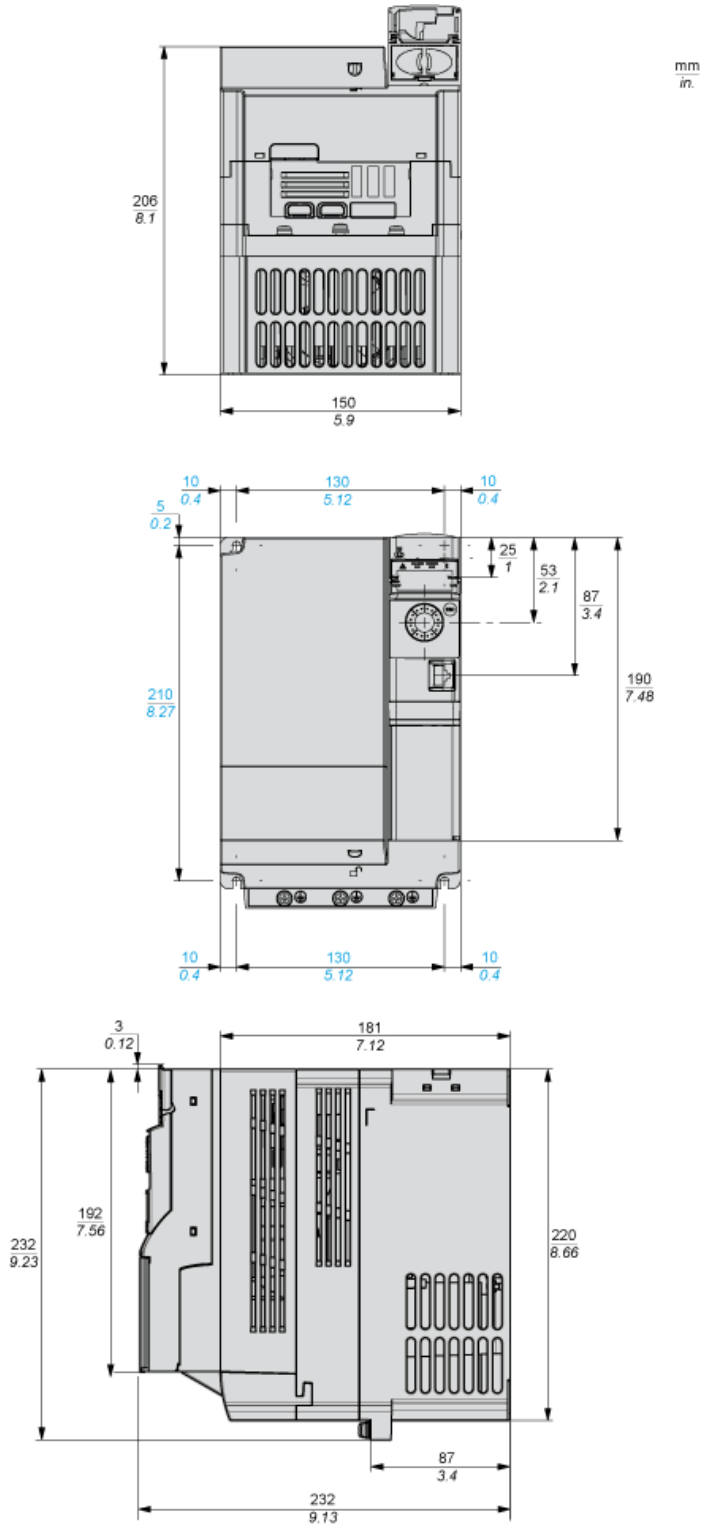

Dimensions

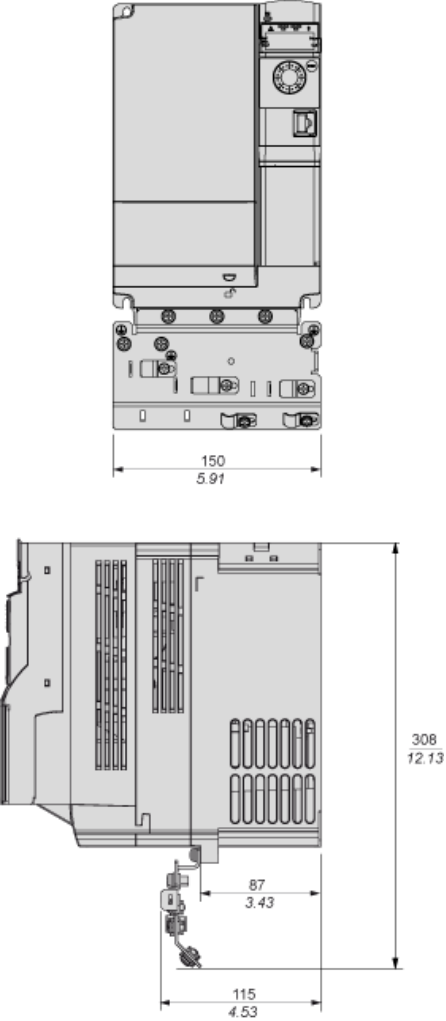

Mounting and Clearance

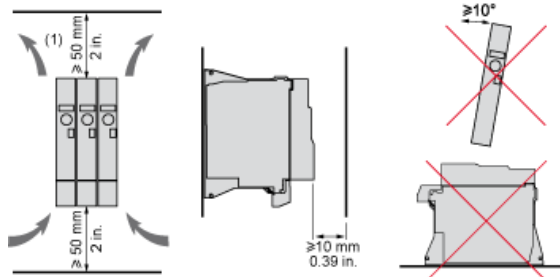

Connection Diagrams

Single or Three-phase Power Supply - Diagram with Line Contactor

Connection diagrams conforming to standards EN 954-1 category 1 and IEC/EN 61508 capacity SIL1, stopping category 0 in accordance with standard IEC/EN 60204-1.

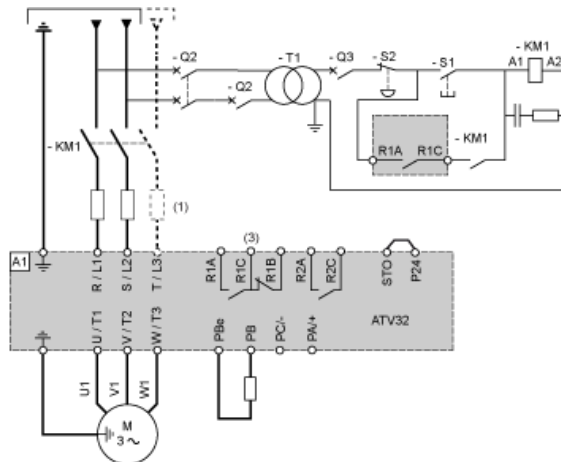

- (1) Line choke (if used)
- (3) Fault relay contacts, for remote signaling of drive status

Single or Three-phase Power Supply - Diagram with Switch Disconnect

Connection diagrams conforming to standards EN 954-1 category 1 and IEC/EN 61508 capacity SIL1, stopping category 0 in accordance with standard IEC/EN 60204-1.

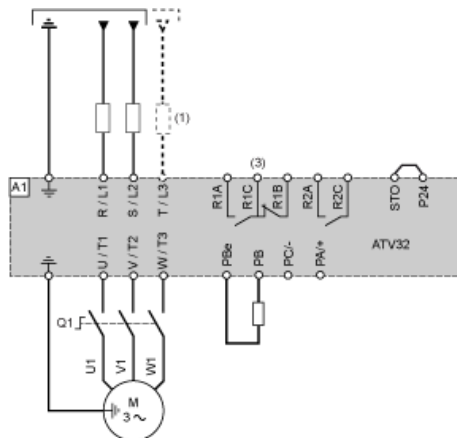

- (1) Line choke (if used)
- (3) Fault relay contacts, for remote signaling of drive status

Diagram with Preventa Safety Module (Safe Torque Off Function)

Connection diagrams conforming to standards EN 954-1 category 3 and IEC/EN 61508 capacity SIL2, stopping category 0 in accordance with standard IEC/EN 60204-1.

When the emergency stop is activated, the drive power supply is cut immediately and the motor stops in freewheel, according to category 0 of standard IEC/EN 60204-1.

A contact on the Preventa XPS AC module must be inserted in the brake control circuit to engage it safely when the STO (Safe Torque Off) safety function is activated.

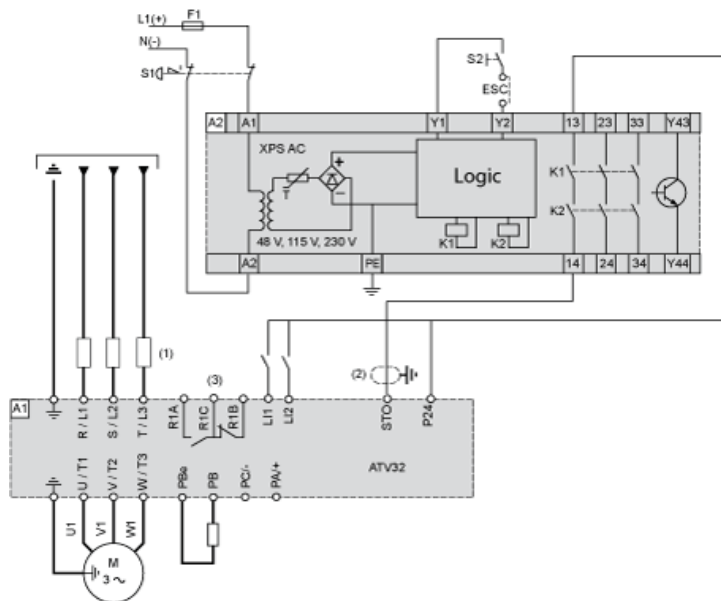

- (1) Line choke (if used)
- (2) It is essential to connect the shielding to the ground.
- (3) Fault relay contacts, for remote signaling of drive status

The STO safety function integrated into the product can be used to implement an "EMERGENCY STOP" (IEC 60204-1) for category 0 stops. With an additional, approved EMERGENCY STOP module, it is also possible to implement category 1 stops.

STO function

The STO safety function is triggered via 2 redundant inputs. The circuits of the two inputs must be separate so that there are always two channels. The switching process must be simultaneous for both inputs (offset < 1 s).

The power stage is disabled and an error message is generated. The motor can no longer generate torque and coasts down without braking. A restart is possible after resetting the error message with a "Fault Reset".

The power stage is disabled and an error message is generated if only one of the two inputs is switched off or if the time offset is too great. This error message can only be reset by switching off the product.

Diagram without Preventa Safety Module

Connection diagrams conforming to standards EN 954-1 category 2 and IEC/EN 61508 capacity SIL1, stopping category 0 in accordance with standard IEC/EN 60204-1.

The connection diagram below is suitable for use with machines with a short freewheel stop time (machines with low inertia or high resistive torque).

When the emergency stop is activated, the drive power supply is cut immediately and the motor stops in freewheel, according to category 0 of standard IEC/EN 60204-1.

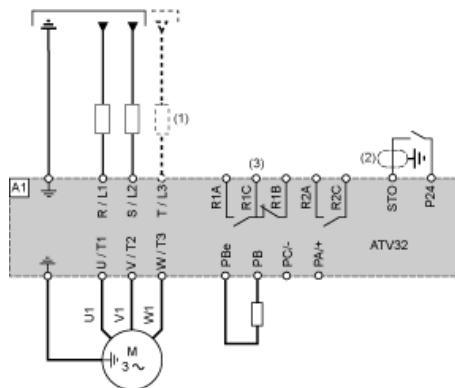

- (1) Line choke (if used)
- (2) It is essential to connect the shielding to the ground.
- (3) Fault relay contacts, for remote signaling of drive status

The STO safety function integrated into the product can be used to implement an "EMERGENCY STOP" (IEC 60204-1) for category 0 stops.

Control Connection Diagram in Source Mode

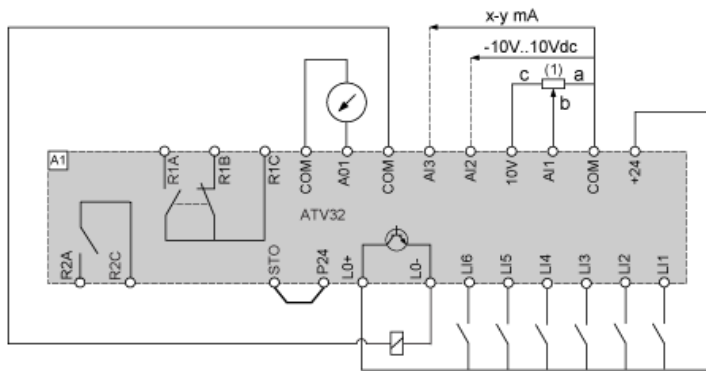

(1) Reference potentiometer SZ1RV1202 (2.2 kΩ) or similar (10 kΩ maximum)

Derating Curves

Derating curve for the nominal drive current (I_n) as a function of temperature and switching frequency.

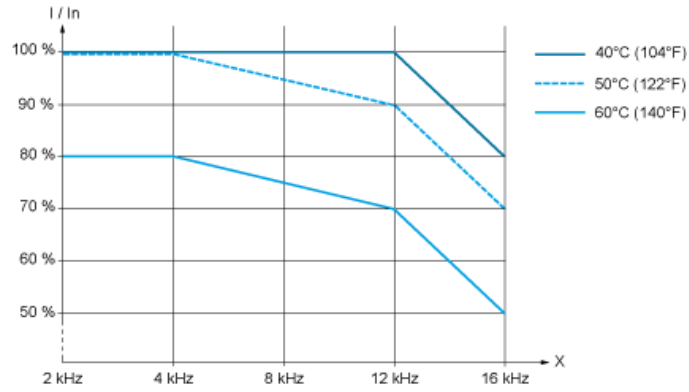

X Switching frequency

Above 4 kHz, the drive will reduce the switching frequency automatically in the event of an excessive temperature rise.

Sink / Source Switch Configuration (SW1)

The logic input switch (SW1) is used to adapt the operation of the logic inputs to the technology of the programmable controller outputs.

Switch SW1 set to "Source" position

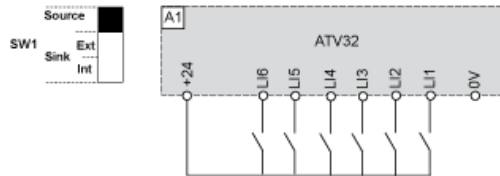

Switch SW1 set to "Source" position and use of an external power supply for the LIs

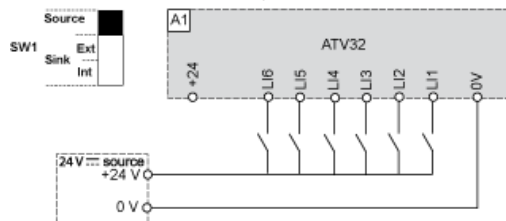

Switch SW1 set to "Sink Int" position

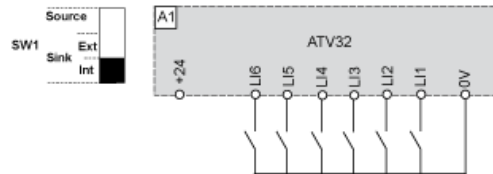

Switch SW1 set to "Sink Ext" position

