



FEATURES

- 1. Compact high-capacity control relay**
In the same external dimensions as an HC relay, this compact power relay enables high-capacity control: 15 A for 1 Form C, 10 A for 2 Form C.
- 2. Designed for high reliability**
High operational reliability is achieved by solder-less construction, in which all connections between lead wires and the contact springs and terminal plate are welded.
- 3. Various types provided in rich lineup. LED indicator type also available.**
- 4. The terminals are compatible with #187 series tab terminals.**
- 5. UL, CSA approval is standard**

TYPICAL APPLICATIONS

Suitable for factory automation equipment and automotive devices

- 1. Control panels, power supply equipment, molding equipment, machine tools, welding equipment, agricultural equipment, etc.**
- 2. Office equipment, automatic vending machines, telecommunications equipment, disaster prevention equipment, copiers, measuring devices, medical equipment, amusement devices, etc.**
- 3. All types of household appliance**

About Cd-free contacts

We have introduced Cadmium free type products to reduce Environmental Hazardous Substances. (The suffix "F" should be added to the part number.) Please replace parts containing Cadmium with Cadmium-free products and evaluate them with your actual application before use because the life of a relay depends on the contact material and load.

RoHS Directive compatibility information
<http://www.mew.co.jp/ac/e/environment/>

ORDERING INFORMATION

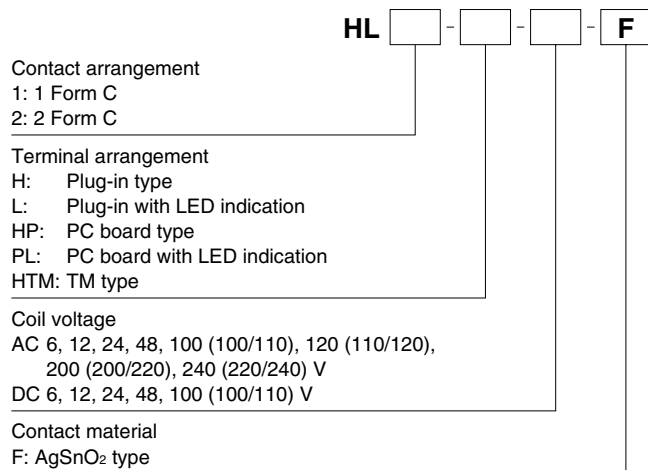

Notes: UL/CSA approved type is standard.
Please inquire about TV approved products.

HL

TYPES

1. Plug-in type

Coil voltage	1 Form C	2 Form C
	Part No.	Part No.
6V AC	HL1-H-AC6V-F	HL2-H-AC6V-F
12V AC	HL1-H-AC12V-F	HL2-H-AC12V-F
24V AC	HL1-H-AC24V-F	HL2-H-AC24V-F
48V AC	HL1-H-AC48V-F	HL2-H-AC48V-F
100/110V AC	HL1-H-AC100V-F	HL2-H-AC100V-F
110/120V AC	HL1-H-AC120V-F	HL2-H-AC120V-F
200/220V AC	HL1-H-AC200V-F	HL2-H-AC200V-F
220/240V AC	HL1-H-AC240V-F	HL2-H-AC240V-F
6V DC	HL1-H-DC6V-F	HL2-H-DC6V-F
12V DC	HL1-H-DC12V-F	HL2-H-DC12V-F
24V DC	HL1-H-DC24V-F	HL2-H-DC24V-F
48V DC	HL1-H-DC48V-F	HL2-H-DC48V-F
100/110V DC	HL1-H-DC100V-F	HL2-H-DC100V-F

Standard packing: Carton: 20 pcs.; Case: 200 pcs.

2. Plug-in type (with LED indication)

Coil voltage	1 Form C	2 Form C
	Part No.	Part No.
6V AC	HL1-L-AC6V-F	HL2-L-AC6V-F
12V AC	HL1-L-AC12V-F	HL2-L-AC12V-F
24V AC	HL1-L-AC24V-F	HL2-L-AC24V-F
48V AC	HL1-L-AC48V-F	HL2-L-AC48V-F
100/110V AC	HL1-L-AC100V-F	HL2-L-AC100V-F
110/120V AC	HL1-L-AC120V-F	HL2-L-AC120V-F
200/220V AC	HL1-L-AC200V-F	HL2-L-AC200V-F
220/240V AC	HL1-L-AC240V-F	HL2-L-AC240V-F
6V DC	HL1-L-DC6V-F	HL2-L-DC6V-F
12V DC	HL1-L-DC12V-F	HL2-L-DC12V-F
24V DC	HL1-L-DC24V-F	HL2-L-DC24V-F
48V DC	HL1-L-DC48V-F	HL2-L-DC48V-F
100/110V DC	HL1-L-DC100V-F	HL2-L-DC100V-F

Standard packing: Carton: 20 pcs.; Case: 200 pcs.

3. PC board type

Coil voltage	1 Form C	2 Form C
	Part No.	Part No.
6V AC	HL1-HP-AC6V-F	HL2-HP-AC6V-F
12V AC	HL1-HP-AC12V-F	HL2-HP-AC12V-F
24V AC	HL1-HP-AC24V-F	HL2-HP-AC24V-F
48V AC	HL1-HP-AC48V-F	HL2-HP-AC48V-F
100/110V AC	HL1-HP-AC100V-F	HL2-HP-AC100V-F
110/120V AC	HL1-HP-AC120V-F	HL2-HP-AC120V-F
200/220V AC	HL1-HP-AC200V-F	HL2-HP-AC200V-F
220/240V AC	HL1-HP-AC240V-F	HL2-HP-AC240V-F
6V DC	HL1-HP-DC6V-F	HL2-HP-DC6V-F
12V DC	HL1-HP-DC12V-F	HL2-HP-DC12V-F
24V DC	HL1-HP-DC24V-F	HL2-HP-DC24V-F
48V DC	HL1-HP-DC48V-F	HL2-HP-DC48V-F
100/110V DC	HL1-HP-DC100V-F	HL2-HP-DC100V-F

Standard packing: Carton: 20 pcs.; Case: 200 pcs.

4. PC board type (with LED indication)

Coil voltage	1 Form C	2 Form C
	Part No.	Part No.
6V AC	HL1-PL-AC6V-F	HL2-PL-AC6V-F
12V AC	HL1-PL-AC12V-F	HL2-PL-AC12V-F
24V AC	HL1-PL-AC24V-F	HL2-PL-AC24V-F
48V AC	HL1-PL-AC48V-F	HL2-PL-AC48V-F
100/110V AC	HL1-PL-AC100V-F	HL2-PL-AC100V-F
110/120V AC	HL1-PL-AC120V-F	HL2-PL-AC120V-F
200/220V AC	HL1-PL-AC200V-F	HL2-PL-AC200V-F
220/240V AC	HL1-PL-AC240V-F	HL2-PL-AC240V-F
6V DC	HL1-PL-DC6V-F	HL2-PL-DC6V-F
12V DC	HL1-PL-DC12V-F	HL2-PL-DC12V-F
24V DC	HL1-PL-DC24V-F	HL2-PL-DC24V-F
48V DC	HL1-PL-DC48V-F	HL2-PL-DC48V-F
100/110V DC	HL1-PL-DC100V-F	HL2-PL-DC100V-F

Standard packing: Carton: 20 pcs.; Case: 200 pcs.

5. TM type

Coil voltage	1 Form C	2 Form C
	Part No.	Part No.
6V AC	HL1-HTM-AC6V-F	HL2-HTM-AC6V-F
12V AC	HL1-HTM-AC12V-F	HL2-HTM-AC12V-F
24V AC	HL1-HTM-AC24V-F	HL2-HTM-AC24V-F
48V AC	HL1-HTM-AC48V-F	HL2-HTM-AC48V-F
100/110V AC	HL1-HTM-AC100V-F	HL2-HTM-AC100V-F
110/120V AC	HL1-HTM-AC120V-F	HL2-HTM-AC120V-F
200/220V AC	HL1-HTM-AC200V-F	HL2-HTM-AC200V-F
220/240V AC	HL1-HTM-AC240V-F	HL2-HTM-AC240V-F
6V DC	HL1-HTM-DC6V-F	HL2-HTM-DC6V-F
12V DC	HL1-HTM-DC12V-F	HL2-HTM-DC12V-F
24V DC	HL1-HTM-DC24V-F	HL2-HTM-DC24V-F
48V DC	HL1-HTM-DC48V-F	HL2-HTM-DC48V-F
100/110V DC	HL1-HTM-DC100V-F	HL2-HTM-DC100V-F

Standard packing: Carton: 20 pcs.; Case: 200 pcs.

RATING

1. Coil data

1) AC coils

Nominal coil voltage	Nominal coil current (mA)		Nominal operating power (VA)		Pick-up voltage (at 20°C 68°F)	Drop-out voltage (at 20°C 68°F)	Inductance (H)		Max. allowable voltage
	50Hz	60Hz	50Hz	60Hz			When drop-out	When operating	
6V AC	224	200	1.3	1.2	80%V or less of nominal voltage (Initial)	30%V or more of nominal voltage (Initial)	0.078	0.074	110%V of nominal voltage
12V AC	111	100	1.3	1.2			0.312	0.295	
24V AC	56	50	1.3	1.2			1.243	1.181	
48V AC	28	25	1.3	1.2			4.974	4.145	
100/110V AC	13.4/14.7	12/13.2	1.3	1.2			23.75	20.63	
110/120V AC	12.2/13.5	10.9/11.9	1.3	1.2			27.19	25.57	
200/220V AC	6.7/7.4	6/6.6	1.3	1.2			85.98	81.76	

- Notes: 1. The relay operates in a range of 80% to 110% V of the voltage rating, but ideally, in consideration of temporary voltage fluctuations, it should be operated at the rated voltage.
In particular, for AC operation, if the applied voltage drops to 80% V or more below the rated voltage, humming will occur and a large current will flow leading possibly to coil burnout.
2. The maximum allowable voltage is the maximum voltage fluctuation value for the coil power supply. This value is not a permissible value for continuous operation. (This value differs depending on the ambient temperature. Please contact us for details.)

2) DC coils (at 20°C 68°F)

Nominal coil voltage	Nominal coil current (mA)	Nominal operating power (W)	Coil resistance (Ω)	Pick-up voltage (at 20°C 68°F)	Drop-out voltage (at 20°C 68°F)	Max. allowable voltage (at 70°C 158°F)
6V DC	150	0.9	40	80%V or less of nominal voltage (Initial)	10%V or more of nominal voltage (Initial)	110%V of nominal voltage
12V DC	75	0.9	160			
24V DC	37	0.9	650			
48V DC	18.5	0.9	2,600			
100/110V DC	10	1.0	10,000			

- Notes: 1. The rated excitation current is $\pm 10\%$ (20°C 68°F).
2. The coil resistance for DC operation is the value measured when the coil temperature is 20°C 68°F. Compensate $\pm 0.4\%$ for every $\pm 1^\circ\text{C}$ change in temperature.
3. The relay operates in a range of 80% to 110% V of the voltage rating, but ideally, in consideration of temporary voltage fluctuations, it should be operated at the rated voltage.
4. For use with 200 V DC, connect a 10 KΩ (5W) resistor, in series, to the 100 V DC relay.
5. The maximum allowable voltage is the maximum voltage fluctuation value for the coil power supply. This value is not a permissible value for continuous operation. (This value differs depending on the ambient temperature. Please contact us for details.)

2. Specifications

Characteristics	Item	Specifications	
Contact	Initial contact resistance, max	Max. 50 mΩ (By voltage drop 6 V DC 1A)	
	Contact material	AgSnO ₂ type	
Rating	Nominal switching capacity	1 Form C: 15A 125V AC, 10A 250V AC (resistive load) 2 Form C: 10A 125V AC (resistive load)	
	Min. switching capacity (Reference value)*1	100mA 5V DC	
Electrical characteristics	Insulation resistance (Initial)	Min. 100MΩ (at 500V DC) Measurement at same location as "Initial breakdown voltage" section.	
	Breakdown voltage (Initial)	Between open contacts	1,000 Vrms for 1min. (Detection current: 10mA.)
		Between contact sets	1,500 Vrms for 1min. (Detection current: 10mA.)
		Between contact and coil	2,000 Vrms for 1min. (Detection current: 10mA.)
	Temperature rise	Max. 80°C (By resistive method, nominal voltage)	
	Operate time (at 20°C 68°F)*2	DC type/AC type: Max. 25ms (Nominal voltage applied to the coil, excluding contact bounce time.)	
Release time (at 20°C 68°F)*2	DC type/AC type: Max. 25ms (Nominal voltage applied to the coil, excluding contact bounce time.) (without diode)		
Mechanical characteristics	Shock resistance	Functional	Min. 196 m/s ² (Half-wave pulse of sine wave: 11 ms; detection time: 10μs.)
		Destructive	Min. 980 m/s ² (Half-wave pulse of sine wave: 6 ms.)
	Vibration resistance	Functional	10 to 55 Hz at double amplitude of 1 mm (Detection time: 10μs.)
		Destructive	10 to 55 Hz at double amplitude of 2 mm
Expected life	Mechanical	AC type: 5×10^7 (at 180 cpm), DC type: 10^8 (at 180 cpm)	
	Electrical	AC load	1 Form C: 15A 125V AC, 10A 250V AC resistive load (cosφ=1) Life switching cycle: Min. 5×10^5 2 Form C: 10A 125V AC resistive load (cosφ=1) Life switching cycle: Min. 3×10^5
		DC load	1 Form C: 3A 30V DC resistive load (cosφ=1) Life switching cycle: Min. 5×10^5 2 Form C: 3A 30V DC resistive load (cosφ=1) Life switching cycle: Min. 5×10^5
Conditions	Conditions for operation, transport and storage*3	Ambient temperature: -50°C to +70°C -58°F to +158°F (Without LED indication); -50°C to +60°C -58°F to +140°F (With LED indication) Humidity: 5 to 85% R.H. (Not freezing and condensing at low temperature)	
	Max. Operating speed	20 cpm (at max. rating)	
Unit weight		Approx. 35g 1.23 oz	

Notes: If integrating into electrical appliances that will be subject to compliance to the Electrical Appliance and Material Safety Law, please use in an ambient temperature between -50°C to +40°C -58°F to +104°F (AC type).

*1 This value can change due to the switching frequency, environmental conditions and desired reliability level, therefore it is recommended to check this with the actual load.

*2 For the AC coil types, the operate/release time will differ depending on the phase.

*3 The upper operation ambient temperature limit is the maximum temperature that can satisfy the coil temperature rise value. Refer to 4. Conditions for operation, transport and storage mentioned in AMBIENT ENVIRONMENT.

REFERENCE DATA

Switching capacity range (1 Form C)

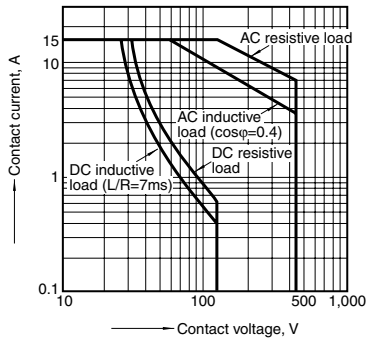

Switching capacity range (2 Form C)

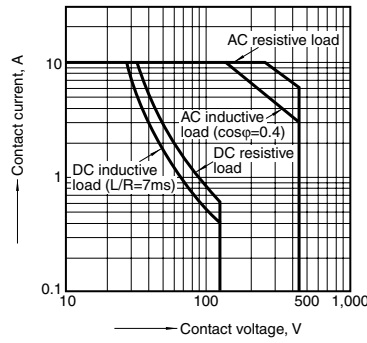

DIMENSIONS (Unit: mm inch)

1. Plug-in type
1 Form C



External dimensions

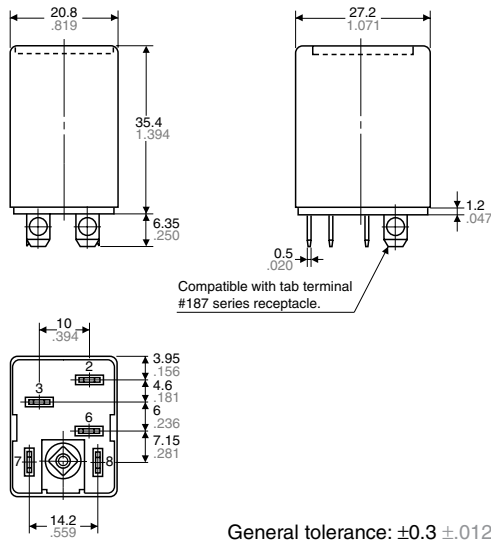

General tolerance: $\pm 0.3 \pm 0.012$

Schematic (Bottom view)
Standard type

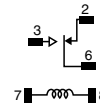

LED AC type

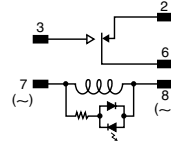

LED DC type

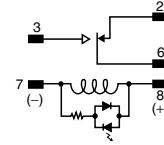

2 Form C



External dimensions

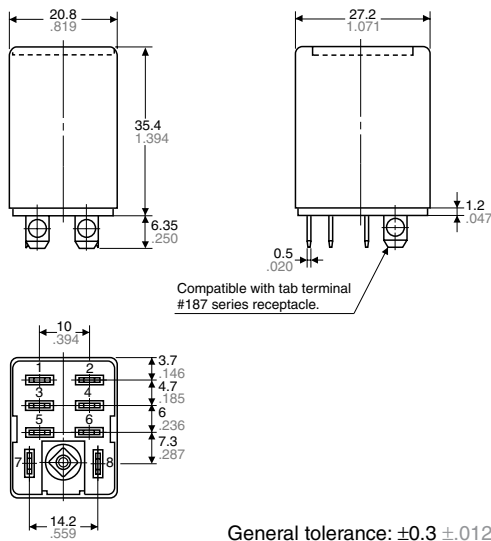

General tolerance: $\pm 0.3 \pm 0.012$

Schematic (Bottom view)
Standard type

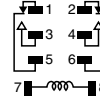

LED AC type

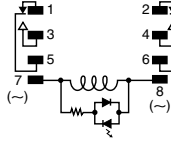

LED DC type

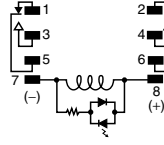

2. PC board type
1 Form C



External dimensions

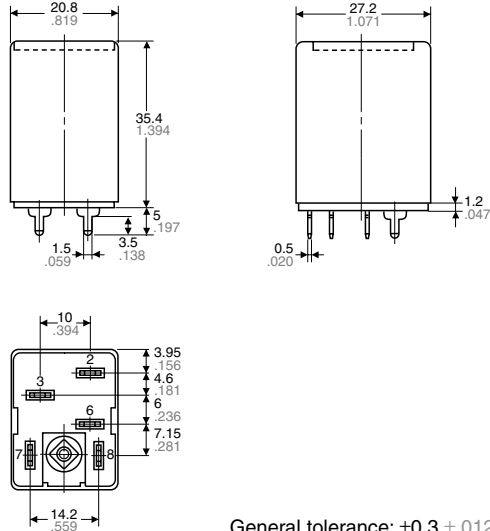

General tolerance: $\pm 0.3 \pm 0.12$

Schematic (Bottom view)
Standard type

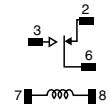

LED AC type

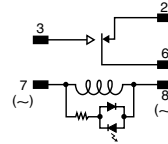

LED DC type

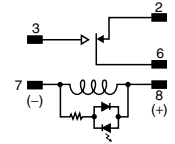

PC board pattern (Bottom view)

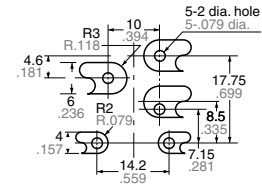

Tolerance: $\pm 0.1 \pm 0.04$

2 Form C



External dimensions

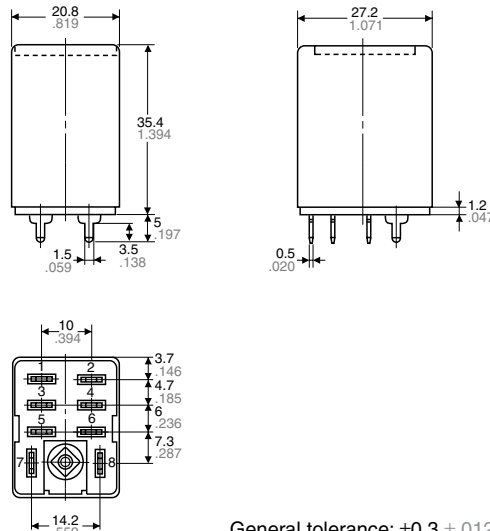

General tolerance: $\pm 0.3 \pm 0.12$

Schematic (Bottom view)
Standard type

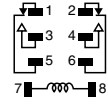

LED AC type

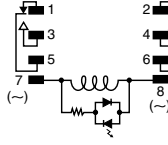

LED DC type

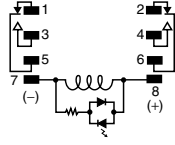

PC board pattern (Bottom view)

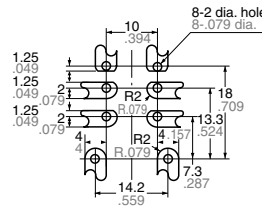

Tolerance: $\pm 0.1 \pm 0.04$

3. TM type 1 Form C



External dimensions

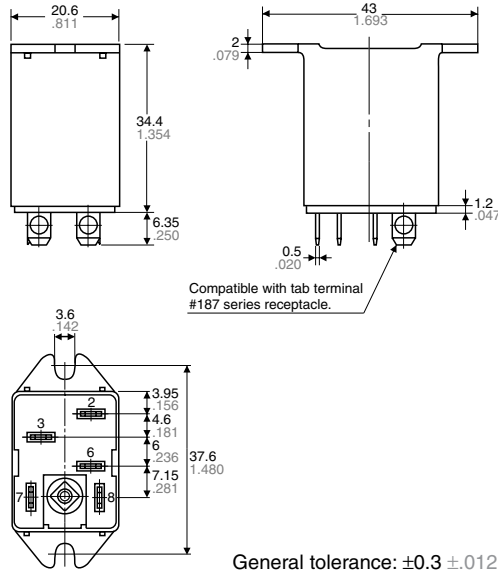

Schematic (Bottom view)

Standard type

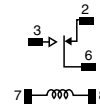

Chassis (Panel) cutout

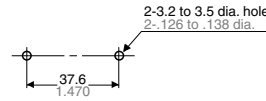

Chassis (Panel) cutout in tandem mounting

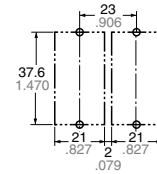

Tolerance: $\pm 0.1 \pm 0.004$

- Notes:
1. If connecting to #187 series tab terminals, use AMP Faston #187 series or #187 tab terminals conforming to UL or CSA inch-standard dimensions.
 2. In mounting, use M3 screws and M3 washers.
 3. When mounting TM types, use washers to prevent damage or distortion to the polycarbonate cover.
 4. When tightening fixing screws, the optimum torque range should be 0.294 to 0.49 N·m, (3 to 5 kgf·cm). Moreover, use washers to prevent loosening.

2 Form C



External dimensions

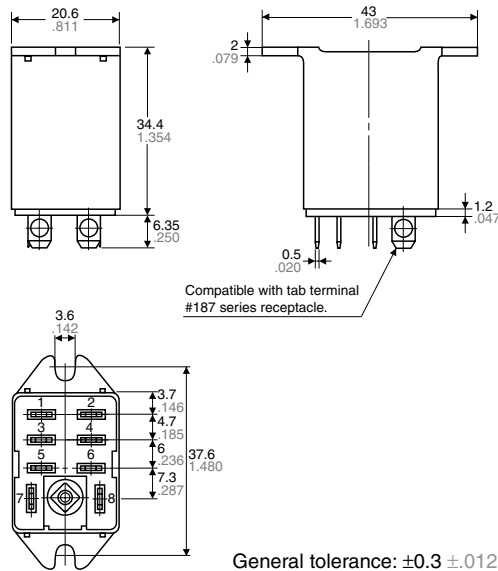

Schematic (Bottom view)

Standard type

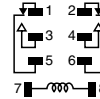

Chassis (Panel) cutout

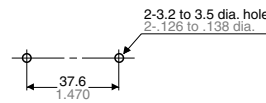

Chassis (Panel) cutout in tandem mounting

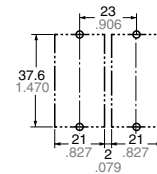

Tolerance: $\pm 0.1 \pm 0.004$

- Notes:
1. If connecting to #187 series tab terminals, use AMP Faston #187 series or #187 tab terminals conforming to UL or CSA inch-standard dimensions.
 2. In mounting, use M3 screws and M3 washers.
 3. When mounting TM types, use washers to prevent damage or distortion to the polycarbonate cover.
 4. When tightening fixing screws, the optimum fixing screw range should be 0.294 to 0.49 N·m, (3 to 5 kgf·cm). Moreover, use washers to prevent loosening.

For Cautions for Use, see Relay Technical Information.

TYPES

- HL relay connection accessories include plug-in sockets, PC board sockets, and terminal socket for DIN rails.
- UL/CSA approval is standard.

- A hold-down clip is included in the package.



The fixing method is the same as for HL sockets, HC sockets and ordinary HC terminal sockets.

HC/HL-LEAF-SPRING-MK



The fixing method is the same as for the HL DIN rail terminal sockets and the HC DIN terminal sockets.

HC/HL-LEAF-SPRING-K

RoHS Directive compatibility information
<http://www.mew.co.jp/ac/e/environment/>

Type	No. of poles	Item	Part No.	Packing quantity	
				Carton	Case
Plug-in socket	1-pole	HL1 socket	HL1-SS-K	20 pcs.	200 pcs.
	2-pole	HL2 socket	HL2-SS-K		
PC board socket	1-pole	HL1 PC board socket	HL1-PS-K		
	2-pole	HL2 PC board socket	HL2-PS-K		
DIN rail terminal socket	1/2-pole (common)	HL2-DIN terminal socket	HL2-SFD-K	10 pcs.	100 pcs.

DIMENSIONS (Unit: mm inch)

1. Plug-in type sockets



HL1 Socket (HL1-SS-K)



HL2 Socket (HL2-SS-K)

HL1 socket External dimensions

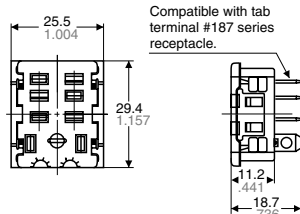

Note: The external and mounting dimensions of HL2 socket are the same for HL1 socket types. Only the number of terminals varies.

General tolerance: $\pm 0.3 \pm .012$

Hold-down clip



Hold-down clip is packaged with the socket.
(Applied to HC sockets and ordinary HC terminal sockets)

Mounting hole diagram

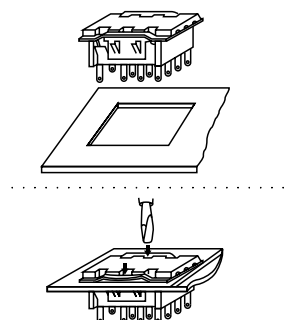

Side-by-side installation

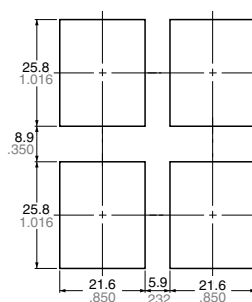

Tolerance: $\pm 0.1 \pm .004$

- Notes:
- Applicable chassis board thickness is 1.0 to 2.0 mm.
 - Installation is easy by inserting the socket from the top into the holes and by depressing the two down arrows on the retention fitting from the front.

HL RELAY ACCESSORIES

2. PC board type sockets

HL2 PC board type socket External dimensions

Hold-down clip



HL1 PC board type socket
(HL1-PS-K)



HL2 PC board type socket
(HL2-PS-K)

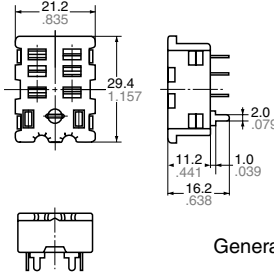

Note: The external and mounting dimensions of HL2 PC board type socket are the same for HL1 PC board type socket. Only the number of terminals varies.

General tolerance: $\pm 0.3 \pm 0.12$



Hold-down clip is packaged with the socket.
(Applied to HC sockets and ordinary HC terminal sockets)

PC board pattern (Bottom view)

Side-by-side installation (For 2 Form C)

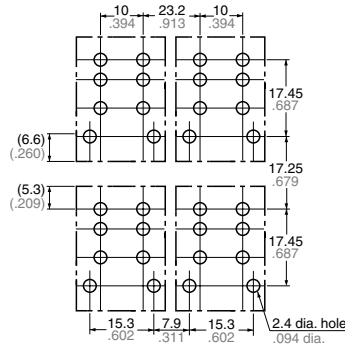
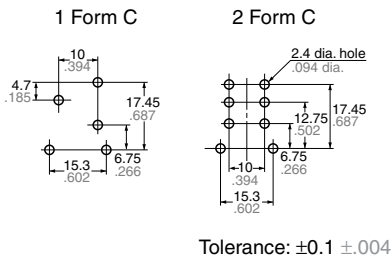

3. Terminal sockets for DIN rail assembly (HL2-SFD-K)

HL2-terminal sockets for DIN rail External dimensions

Schematic

With a relay mounted

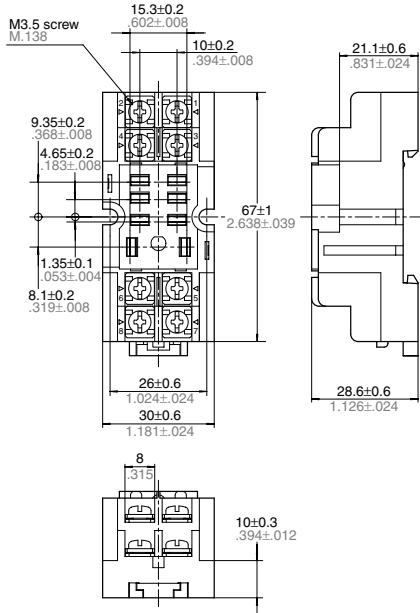

General tolerance: $\pm 0.3 \pm 0.12$

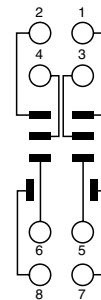

Hold-down clip is packaged with the terminal socket.
(Applied to HC DIN rail terminal sockets)

Mounting hole diagram

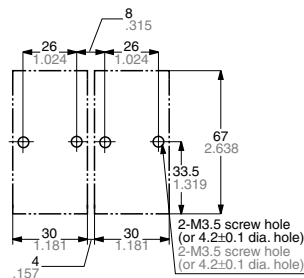

Tolerance: $\pm 0.1 \pm 0.004$

Chassis (Panel) cutout in tandem (side-by-side) mounting

*To prevent damage or distortion, when tightening fixing screws, the optimum torque range should be 0.784 to 0.98 N-m, (8 to 10 kgf-cm).

For Cautions for Use, see Relay Technical Information.