



STB16PF06L

P-CHANNEL 60V - 0.11Ω - 16A D2PAK
STripFET™ MOSFET

Table 1: General Features

TYPE	V _{DSS}	R _{DS(on)}	I _D	P _w
STB16PF06L	60 V	< 0.125 Ω	16 A	70 W

- TYPICAL R_{DS(on)} = 0.11 Ω
- LOW THRESHOLD DEVICE
- LOW GATE CHARGE

DESCRIPTION

This MOSFET is the latest development of STMicroelectronics unique "Single Feature Size™" strip-based process. The resulting transistor shows extremely high packing density for low on-resistance, rugged avalanche characteristics and less critical alignment steps therefore a remarkable manufacturing reproducibility.

APPLICATIONS

- MOTOR CONTROL
- DC-DC CONVERTERS

Figure 1: Package

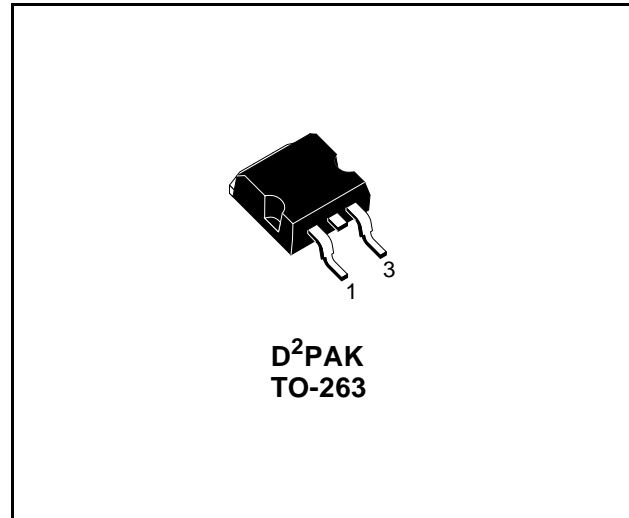

Figure 2: Internal Schematic Diagram

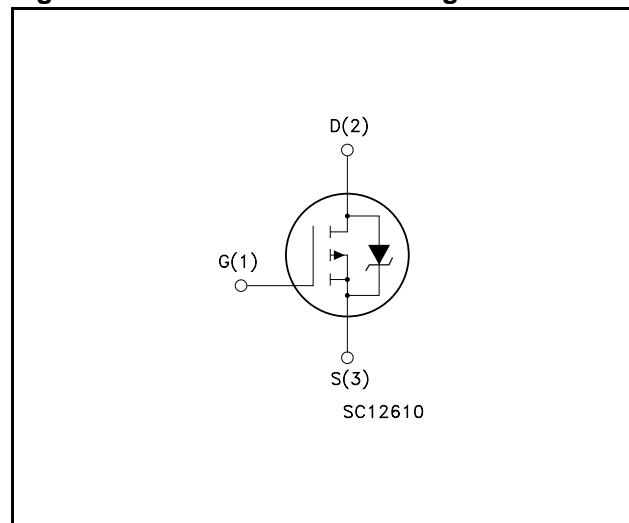

Table 2: Order Codes

PART NUMBER	MARKING	PACKAGE	PACKAGING
STB16PF06LT4	B16PF06L	D ² PAK	TAPE & REEL

Table 3: Absolute Maximum ratings

Symbol	Parameter	Value	Unit
V _{DS}	Drain-source Voltage (V _{GS} = 0)	60	V
V _{DGR}	Drain-gate Voltage (R _{GS} = 20 kΩ)	60	V
V _{GS}	Gate-source Voltage	± 16	V
I _D	Drain Current (continuous) at T _C = 25°C	16	A
I _D	Drain Current (continuous) at T _C = 100°C	11.4	A
I _{DM} (●)	Drain Current (pulsed)	64	A
P _{TOT}	Total Dissipation at T _C = 25°C	70	W
	Derating Factor	0.4	W/°C
dv/dt (1)	Peak Diode Recovery voltage slope	20	V/ns
E _{AS} (2)	Single Pulse Avalanche Energy	250	mJ
T _j T _{stg}	Operating Junction Temperature Storage Temperature	- 55 to 175	°C

(●) Pulse width limited by safe operating area

(1) I_{SD} ≤ 16A, di/dt ≤ 100A/μs, V_{DD} ≤ V_{(BR)DSS}, T_j ≤ T_{JMAX}.

(2) Starting T_j = 25°C, I_D = 8 A, V_{DD} = 30 V

Note: For the P-CHANNEL MOSFET actual polarity of voltages and current has to be reverse

Table 4: Thermal Data

R _{thj-case}	Thermal Resistance Junction-case Max	2.14	°C/W
R _{thj-PCB} (#)	Thermal Resistance Junction-PCB Max	34	°C/W
T _l	Maximum Lead Temperature For Soldering Purpose (1.6 mm from case, for 10sec)	300	°C

(#) When Mounted on 1 inch² FR-4 board, 2 oz of Cu

ELECTRICAL CHARACTERISTICS (T_{CASE} = 25°C UNLESS OTHERWISE SPECIFIED)

Table 5: On/Off

Symbol	Parameter	Test Conditions	Min.	Typ.	Max.	Unit
V _{(BR)DSS}	Drain-source Breakdown Voltage	I _D = 250μA, V _{GS} = 0	60			V
I _{DSS}	Zero Gate Voltage Drain Current (V _{GS} = 0)	V _{DS} = Max Rating V _{DS} = Max Rating, T _C = 125 °C			1 10	μA μA
I _{GSS}	Gate-body Leakage Current (V _{DS} = 0)	V _{GS} = ± 16V			±100	nA
V _{GS(th)}	Gate Threshold Voltage	V _{DS} = V _{GS} , I _D = 100μA	1.5			V
R _{DS(on)}	Static Drain-source On Resistance	V _{GS} = 10V, I _D = 8 A V _{GS} = 5V, I _D = 8 A		0.11 0.130	0.125 0.165	Ω Ω

ELECTRICAL CHARACTERISTICS (CONTINUED)

Table 6: Dynamic

Symbol	Parameter	Test Conditions	Min.	Typ.	Max.	Unit
g_{fs}	Forward Transconductance	$V_{DS} = 10\text{ V}$, $I_D = 3\text{ A}$		7.2		S
C_{iss} C_{oss} C_{rss}	Input Capacitance Output Capacitance Reverse Transfer Capacitance	$V_{DS} = 25\text{ V}$, $f = 1\text{ MHz}$, $V_{GS} = 0$		630 121 49		pF pF pF
$t_{d(on)}$ t_r $t_{d(off)}$ t_f	Turn-on Delay Time Rise Time Turn-off Delay Time Fall Time	$V_{DD} = 30\text{ V}$, $I_D = 8\text{ A}$, $R_G = 4.7\Omega$ $V_{GS} = 4.5\text{ V}$ (Resistive Load , Figure 1)		129 90 25.5 19.5		ns ns ns ns
Q_g Q_{gs} Q_{gd}	Total Gate Charge Gate-Source Charge Gate-Drain Charge	$V_{DD} = 48\text{ V}$, $I_D = 16\text{ A}$, $V_{GS} = 4.5\text{ V}$ (See test circuit, Figure 2)		11.4 5.2 4.7	15.5	nC nC nC

Table 7: Source Drain Diode

Symbol	Parameter	Test Conditions	Min.	Typ.	Max.	Unit
I_{SD} $I_{SDM} (2)$	Source-drain Current Source-drain Current (pulsed)				16 64	A A
$V_{SD} (1)$	Forward On Voltage	$I_{SD} = 8\text{ A}$, $V_{GS} = 0$			1.3	V
t_{rr} Q_{rr} I_{RRM}	Reverse Recovery Time Reverse Recovery Charge Reverse Recovery Current	$I_{SD} = 16\text{ A}$, $di/dt = 100\text{ A}/\mu\text{s}$ $V_{DD} = 20\text{ V}$, $T_j = 150^\circ\text{C}$ (see test circuit, Figure 3)		48.5 87.3 3.6		ns nC A

Note: 1. Pulsed: Pulse duration = 300 μs , duty cycle 1.5 %.
2. Pulse width limited by safe operating area.

Figure 3: Safe Operating Area

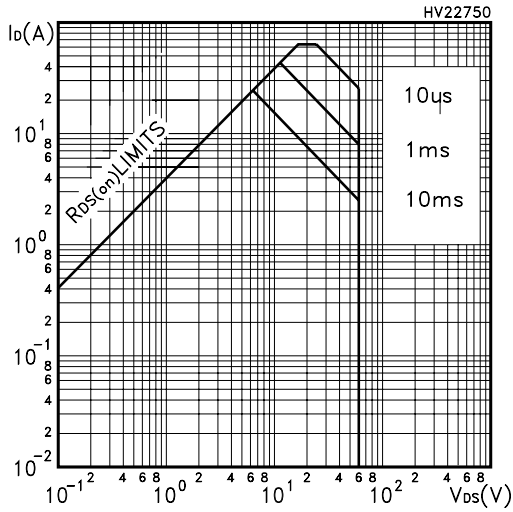

Figure 4: Output Characteristics

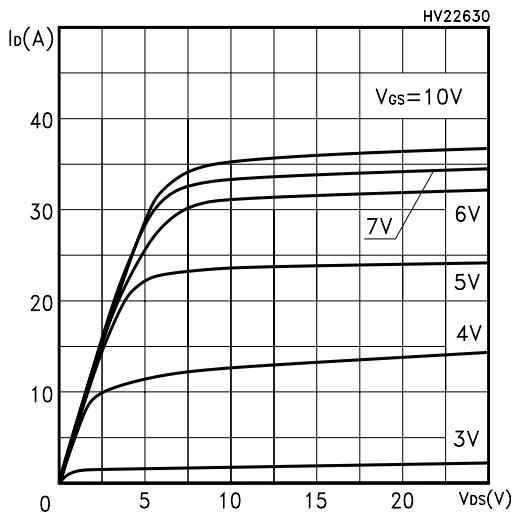

Figure 5: Transconductance

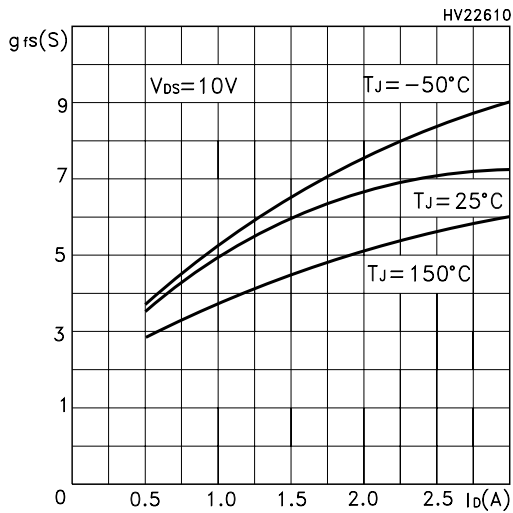

Figure 6: Thermal Impedance

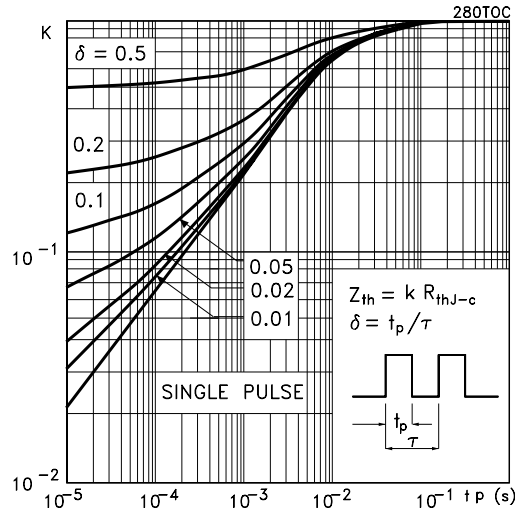

Figure 7: Transfer Characteristics

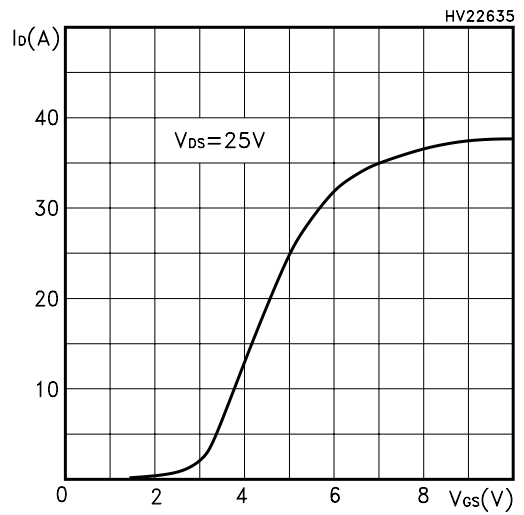

Figure 8: Static Drain-source On Resistance

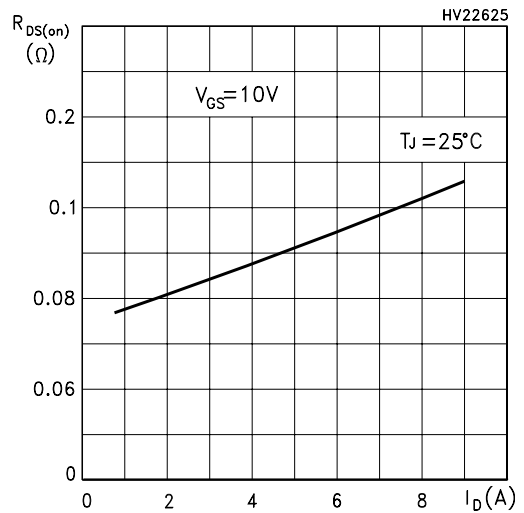

Figure 9: Gate Charge vs Gate-source Voltage

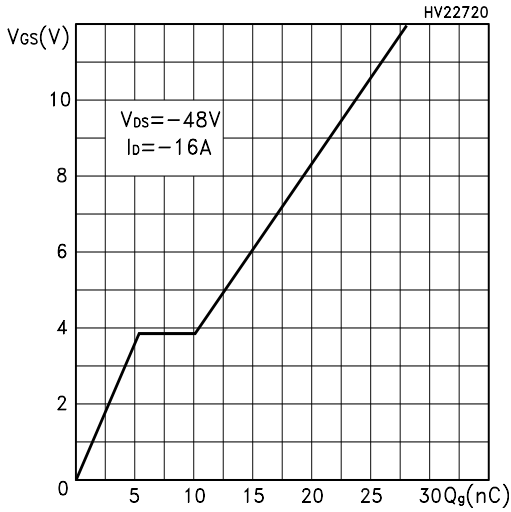

Figure 12: Capacitance Variations

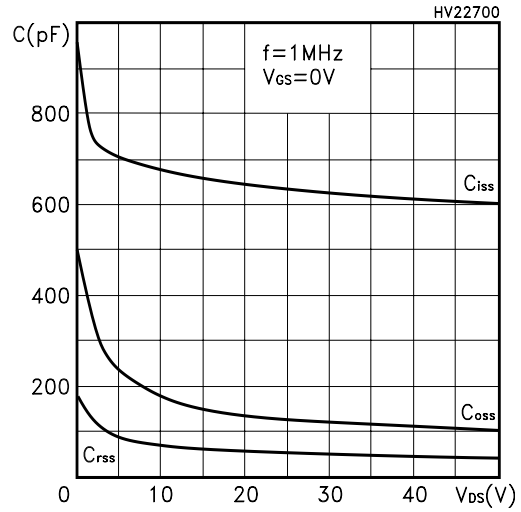

Figure 10: Normalized Gate Threshold Voltage vs Temperature

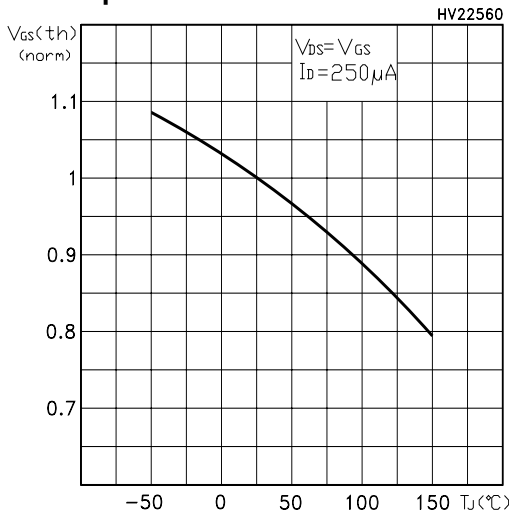

Figure 13: Normalized On Resistance vs Temperature

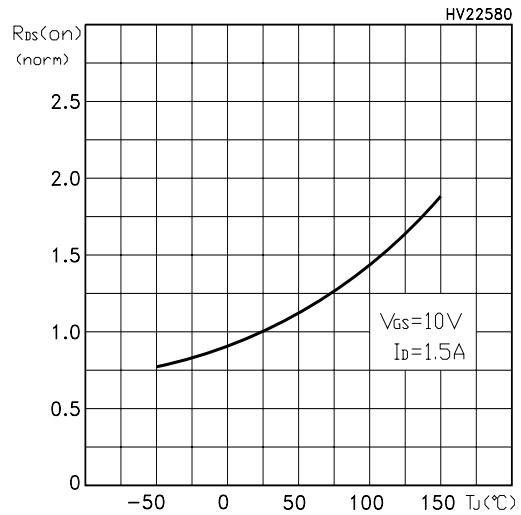

Figure 11: Dource-Drain Diode Forward Characteristics

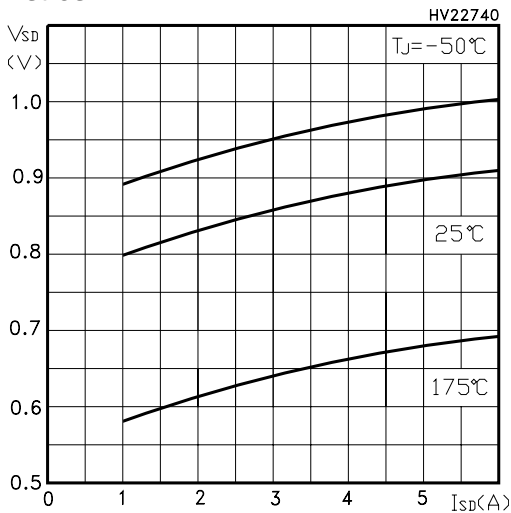

Figure 14: Normalized Breakdown Voltage vs Temperature

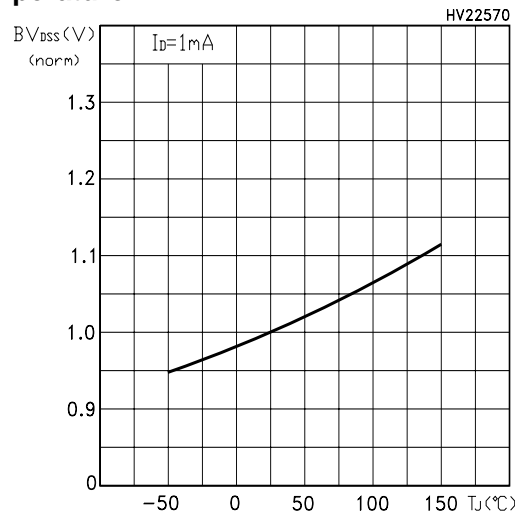

Figure 15: Unclamped Inductive Load Test Circuit

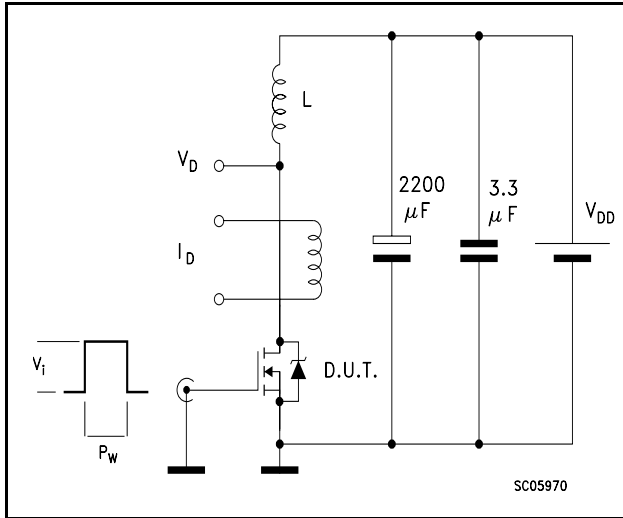

Figure 16: Switching Times Test Circuit For Resistive Load

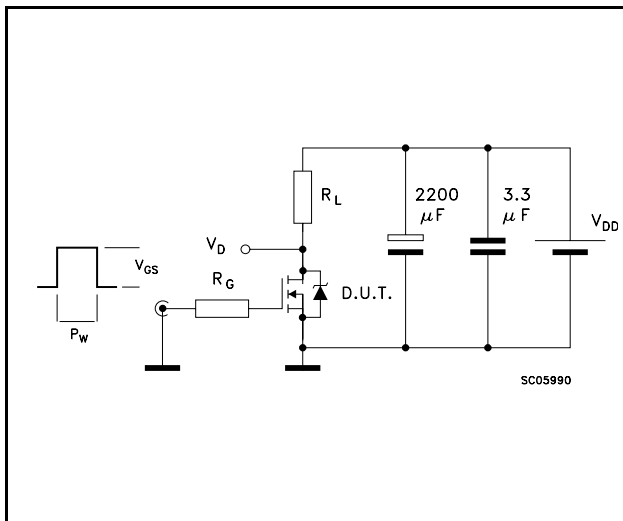

Figure 17: Test Circuit For Inductive Load Switching and Diode Recovery Times

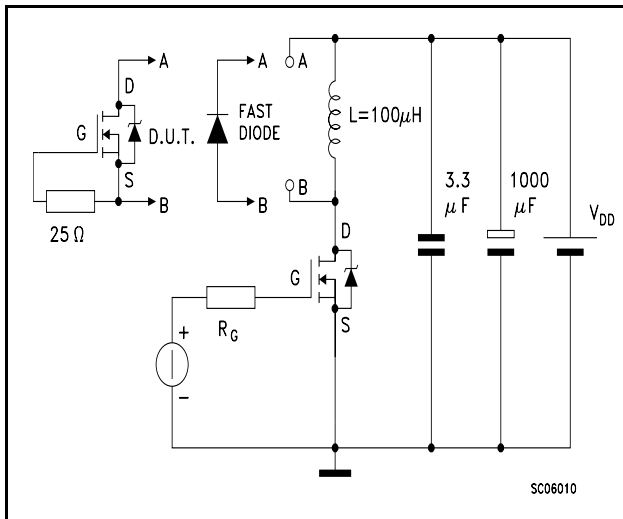

Figure 18: Unclamped Inductive Wafeform

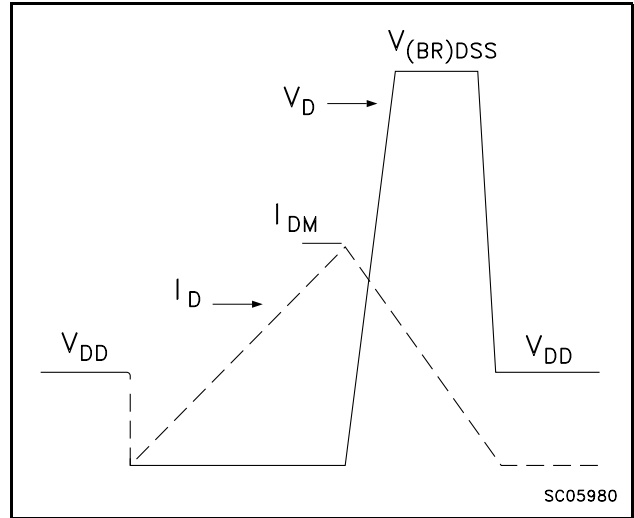
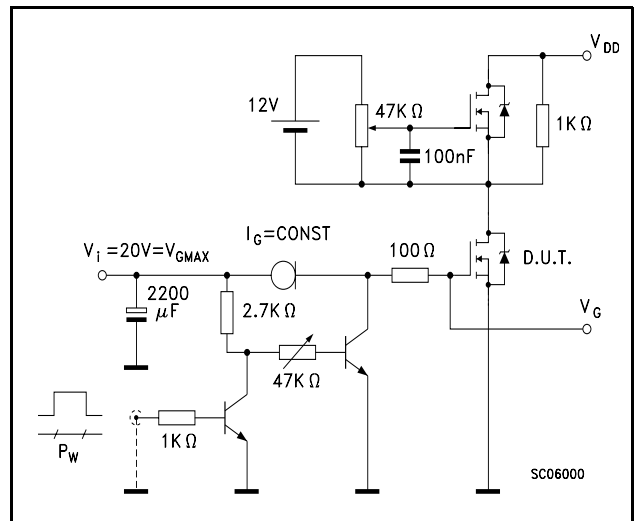
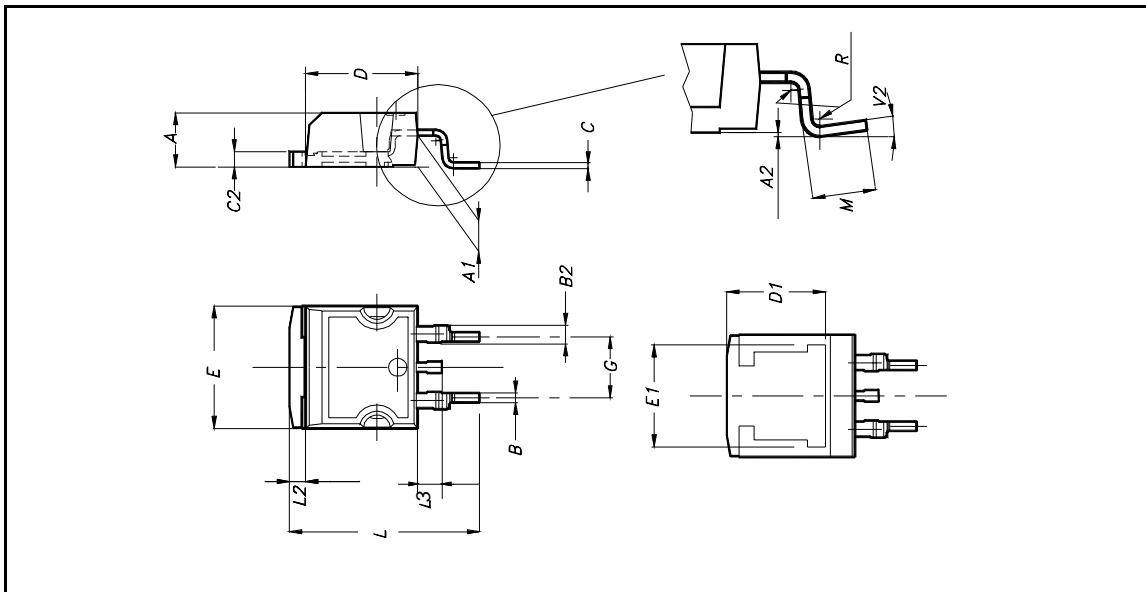

Figure 19: Gate Charge Test Circuit



D²PAK MECHANICAL DATA

DIM.	mm.			inch		
	MIN.	TYP.	MAX.	MIN.	TYP.	MAX.
A	4.4		4.6	0.173		0.181
A1	2.49		2.69	0.098		0.106
A2	0.03		0.23	0.001		0.009
B	0.7		0.93	0.027		0.036
B2	1.14		1.7	0.044		0.067
C	0.45		0.6	0.017		0.023
C2	1.23		1.36	0.048		0.053
D	8.95		9.35	0.352		0.368
D1		8			0.315	
E	10		10.4	0.393		
E1		8.5			0.334	
G	4.88		5.28	0.192		0.208
L	15		15.85	0.590		0.625
L2	1.27		1.4	0.050		0.055
L3	1.4		1.75	0.055		0.068
M	2.4		3.2	0.094		0.126
R		0.4			0.015	
V2	0°		4°			



D²PAK FOOTPRINT

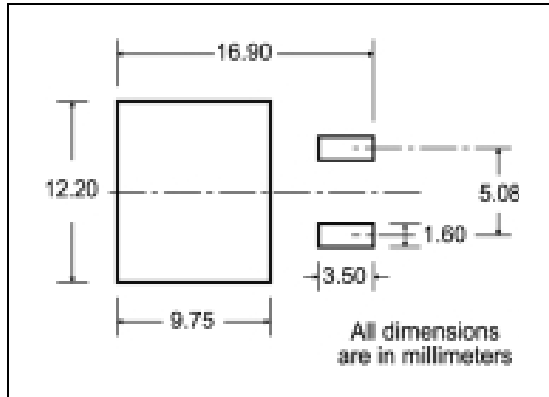

TUBE SHIPMENT (no suffix)*

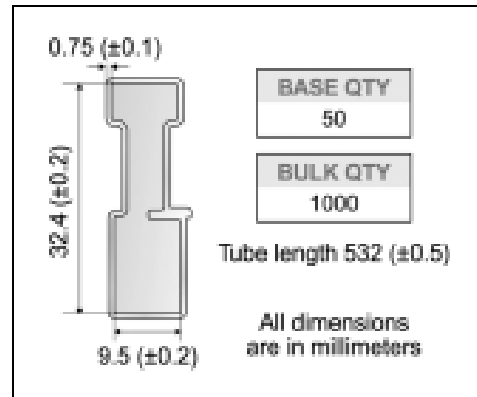

TAPE AND REEL SHIPMENT (suffix "T4")*

40 mm min. Access hole at slot location

Full radius

Tape slot in core for tape start 2.5mm min. width

G measured at hub

REEL MECHANICAL DATA

DIM.	mm		inch	
	MIN.	MAX.	MIN.	MAX.
A		330		12.992
B	1.5		0.059	
C	12.8	13.2	0.504	0.520
D	20.2		0.795	
G	24.4	26.4	0.960	1.039
N	100		3.937	
T		30.4		1.197

BASE QTY	BULK QTY
1000	1000

TAPE MECHANICAL DATA

DIM.	mm		inch	
	MIN.	MAX.	MIN.	MAX.
A0	10.5	10.7	0.413	0.421
B0	15.7	15.9	0.618	0.626
D	1.5	1.6	0.059	0.063
D1	1.59	1.61	0.062	0.063
E	1.65	1.85	0.065	0.073
F	11.4	11.6	0.449	0.456
K0	4.8	5.0	0.189	0.197
P0	3.9	4.1	0.153	0.161
P1	11.9	12.1	0.468	0.476
P2	1.9	2.1	0.075	0.082
R	50		1.574	
T	0.25	0.35	0.0098	0.0137
W	23.7	24.3	0.933	0.956

10 pitches cumulative tolerance on tape + / - 0.2 mm

Center line of cavity

User Direction of Feed

FEED DIRECTION

Bending radius

* on sales type

Table 8: Revision History

Date	Revision	Description of Changes
13/Sep/2004	1	First Release.

Information furnished is believed to be accurate and reliable. However, STMicroelectronics assumes no responsibility for the consequences of use of such information nor for any infringement of patents or other rights of third parties which may result from its use. No license is granted by implication or otherwise under any patent or patent rights of STMicroelectronics. Specifications mentioned in this publication are subject to change without notice. This publication supersedes and replaces all information previously supplied. STMicroelectronics products are not authorized for use as critical components in life support devices or systems without express written approval of STMicroelectronics.

The ST logo is a registered trademark of STMicroelectronics

All other names are the property of their respective owners

© 2004 STMicroelectronics - All Rights Reserved

STMicroelectronics group of companies

Australia - Belgium - Brazil - Canada - China - Czech Republic - Finland - France - Germany - Hong Kong - India - Israel - Italy - Japan - Malaysia - Malta - Morocco - Singapore - Spain - Sweden - Switzerland - United Kingdom - United States of America