



Main

Range of product	Modicon OTB
Product or component type	I/O distributed module
Integrated connection type	CANopen bus SUB-D 9, transmission mode: 2 twisted shielded pairs at 10 kbit/s...1 Mbit/s
Bus type	CANopen S20, profile: DS 401 V2.1, method of access: CSMA/MA multimaster with priority conforming to DR303-2 CANopen S20, profile: DS 401 V2.1, method of access: CSMA/MA multimaster with priority conforming to DS301 V4.02
Discrete input number	12 conforming to EN/IEC 61131 type 1
Discrete input logic	Sink or source
Discrete input current	5 mA for I0...I1 5 mA for I6...I7 7 mA for I2...I5 7 mA for I8...I11
Discrete output number	2 solid state PNP for Q0...Q1 output logic: source 6 relay for Q2...Q7
Discrete output current	2000 mA relay 300 mA solid state

Complementary

Topology	Devices linked by daisy-chaining or tap junctions
Number of slave	0...63
Bus length	0...100 m tap-off length: 0...10 m, 500 kbit/s 0...1000 m tap-off length: 0...120 m, 50 kbit/s 0...250 m tap-off length: 0...10 m, 250 kbit/s 0...2500 m tap-off length: 0...300 m, 20 kbit/s 0...40 m tap-off length: 0...6 m, 800 kbit/s 0...500 m tap-off length: 0...10 m, 125 kbit/s 0...5000 m tap-off length: 0...600 m, 10 kbit/s 0...20 m, 1 Mbit/s
Number of devices per segment	0...16, length of segment 0...205 m 0...32, length of segment 0...185 m 0...64, length of segment 0...160 m
Discrete input voltage	24 V
Discrete input voltage type	DC
Discrete input type	NPN or PNP
Input voltage limits	20.4...26.4 V
Electronic filtering time	0.035 ms for I0...I1 at state 1 0.035 ms for I6...I7 at state 1 0.04 ms for I2...I5 at state 1 0.04 ms for I8...I11 at state 1 0.045 ms for I0...I1 at state 0 0.045 ms for I6...I7 at state 0 0.15 ms for I2...I5 at state 0 0.15 ms for I8...I11 at state 0
Configurable filtering time	0 ms 12 ms 3 ms
Input impedance	3.4 kOhm for I2...I5 3.4 kOhm for I8...I11 5.7 kOhm for I0...I1 5.7 kOhm for I6...I7
Discrete output voltage	24 V DC solid state 240 V AC relay 30 V DC relay

The information provided in this documentation contains general descriptions and/or technical characteristics of the performance of the products contained herein. This documentation is not intended as a substitute for and is not to be used for determining suitability or reliability of these products for specific user applications. It is the duty of any such user or integrator to perform the appropriate and complete risk analysis, evaluation and testing of the products with respect to the relevant specific application or use thereof. Neither Schneider Electric Industries SAS nor any of its affiliates or subsidiaries shall be responsible or liable for misuse of the information contained herein.

Output voltage limits	20.4...28.8 V solid state
Output current limits	360 mA solid state
Current per output common	8 A relay <= 0.72 A solid state
Current consumption	30 mA at 5 V DC(at state 1)relay output 40 mA at 24 V DC(at state 1)relay output 5 mA at 5 V DC(at state 0)relay output
Output overvoltage protection	38...40 V
Tungsten load	8 W for solid state
Response time	300 µs at state 0 for relay 300 µs at state 1 for relay 5 µs at state 0 for solid state 5 µs at state 1 for solid state
Switchable load	>= 0.1 mA
Contact bounce time	<= 1 ms for relay
Leakage current	<= 0.1 mA at state 0 for solid state
Drop-out voltage	<= 1 V at state 1
Insulation between channels and internal logic	1500 Vrms for 1 minute for relay output 500 Vrms for 1 minute for input circuit 500 Vrms for 1 minute for solid state output
Insulation between channels	None
Contact resistance	<= 30 mOhm
Electrical durability	500000 cycles AC-1 with 500 VA load for relay output 500000 cycles AC-14 with 250 VA load for relay output 500000 cycles AC-15 with 200 VA load for relay output 500000 cycles DC-1 with 60 W load for relay output 500000 cycles DC-13 with 30 W load for relay output
Supply circuit type	DC
[Us] rated supply voltage	24 V
Supply voltage limits	20.4...26.2 V
Input current	<= 700 mA at 26.2 V for supply circuit
Inrush current	<= 1 A for solid state output <= 50 A for supply circuit
Power consumption	19 W
Number of I/O expansion module	0...7
I/O expansion capacity	132 with screw terminal discrete I/O module(s) 188 with spring terminal discrete I/O module(s) 244 with HE10 connector discrete I/O module(s) 7 x 8I or 7 x 2I or 7 x (4I/2O) with screw terminal analogue I/O module(s)
Insulation resistance	>= 10 MOhm between I/O and earth terminals >= 10 MOhm between power supply and earth
I/O connection	Removable screw terminal block
Number of common point	1 for input 1 for relay output(1 NO) 1 for relay output(2 NO) 1 for relay output(3 NO) 1 for solid state output
Counting input number	2
Counting capacity	32 bits
Counting frequency	20000 Hz 5000 Hz
Pulse generator number	2
Pulse generator frequency	7 kHz
Pulse generator function	RPLS pulse generator output RPWM pulse width modulation
Marking	CE
Fixing mode	By clips on 35 mm symmetrical DIN rail By screws on panel with fixing kit By screws on solid plate with fixing kit
Status LED	1 LED per channel, green for I/O 1 LED, green for PWR 1 LED, green for RUN 1 LED, red for ERR
Product weight	0.195 kg

Environment

IP degree of protection	IP20
Immunity to microbreaks	10 ms for supply circuit
Dielectric strength	500 V between I/O and earth terminals 500 V between power supply and earth
Standards	CSA CSA C22.2 No. 213 (Class 1 Division 2 Groups A) CSA C22.2 No. 213 (Class 1 Division 2 Groups B) CSA C22.2 No. 213 (Class 1 Division 2 Groups C) CSA C22.2 No. 213 (Class 1 Division 2 Groups D) EN 61131-2 IEC 61131-2 UL 508
Product certifications	CULus
Ambient air temperature for operation	0...55 °C
Ambient air temperature for storage	-25...70 °C
Relative humidity	30...95 % without condensation
Pollution degree	2 conforming to EN 60664 2 conforming to IEC 60664
Operating altitude	0...2000 m
Storage altitude	0...3000 m
Vibration resistance	0.075 mm (f = 10...57 Hz) on 35 mm symmetrical DIN rail 1 gn (f = 57...150 Hz) on 35 mm symmetrical DIN rail
Shock resistance	15 gn for 11 ms conforming to EN 61131 15 gn for 11 ms conforming to IEC 61131
Resistance to electrostatic discharge	4 kV in contact conforming to IEC 61000-4-2 8 kV in air conforming to EN 61000-4-2 8 kV in air conforming to IEC 61000-4-2 4 kV in contact conforming to EN 61000-4-2
Resistance to radiated fields	10 V/m, 80000000...2000000000 Hz conforming to EN 61000-4-3 10 V/m, 80000000...2000000000 Hz conforming to IEC 61000-4-3
Resistance to fast transients	1 kV for 24 V solid state I/O conforming to IEC 61000-4-4 2 kV for 24 V supply conforming to IEC 61000-4-4
RoHS EUR status	Compliant
RoHS EUR conformity date	0908

Network Interface Module

Dimensions

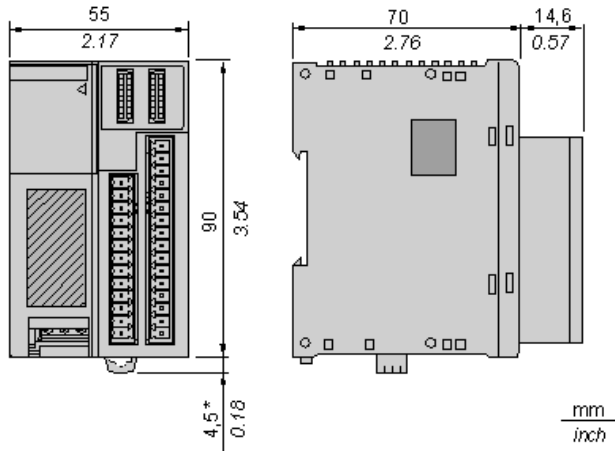

NOTE: * 8.5 mm (0.33 in) when the clamp is pulled out.

Mounting an Island on a Panel or in a Cabinet

Spacing Requirements

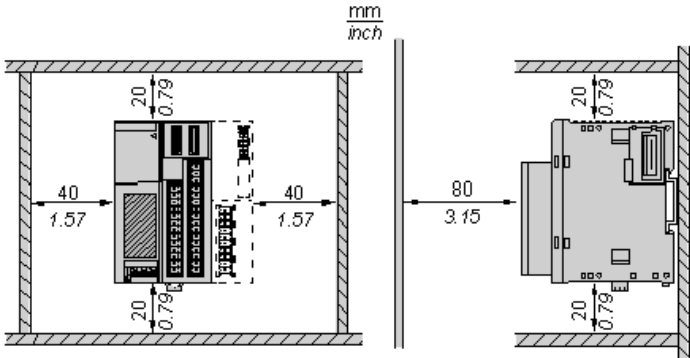

Panel Mounting

Position of the Mounting Holes for the Network Interface Module

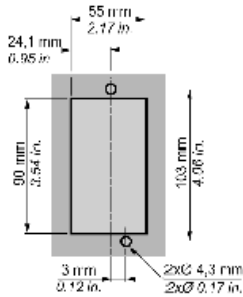

24 Vdc Power Supply

Wiring Diagram

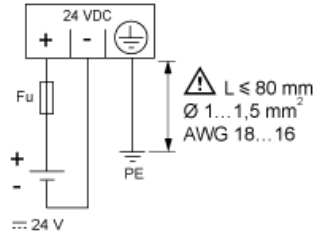

Fu 2 A fast-blow fuse ABE7FU200

Network Interface Module

Wiring Diagram

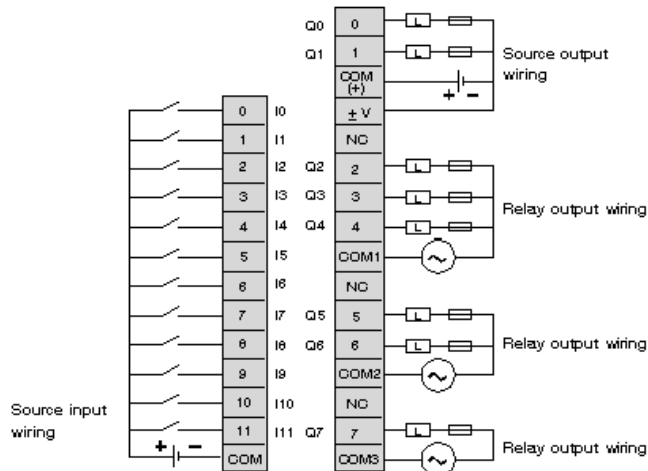

- Output points 0 and 1 are source transistor outputs, all other output points are relay.
- The COM terminals are not connected together internally.
- Connect an appropriate fuse for the load.